

Press release

New 36 XXT truck mounted concrete pump from Liebherr: Light, compact and flexible

- **36 m boom as quintuple folder in new design**
- **Unique Liebherr Powerbloc drive unit**
- **Semi-closed oil circuit offers a multitude of benefits**

Innovative technologies have been combined in a compact machine: The new 36 XXT truck mounted concrete pump combines the advantages of the new quintuple folding boom with the Powerbloc drive unit and the semi-closed oil circuit. The whole thing has also been given a new and appealing look.

Bad Schussenried (Germany), 15 September 2021 – Following extensive testing, sales of Liebherr's completely newly developed 36 XXT truck mounted concrete pump are now starting. The result: A real all-rounder, packed with technical innovations from Liebherr. A large number of the pump drivers' wishes were taken into account, such as ergonomic access steps, simplified accessibility and an expansion of the stowage and storage options.

An extremely compact assembly with no boom overhang at the rear ensures high manoeuvrability in confined spaces. The machine is weight-optimised and therefore travels with a total weight of around 26 tonnes on three axles, depending on the equipment. The XXT support ensures perfect stability. It shows its strengths particularly when it comes to narrow supports, so confined spaces are no problem. The modern radio remote control allows sensitive boom movements. The clear colour display shows the operator all important parameters.

The new 5-piece boom allows maximum flexibility on the construction site. Especially when concreting in buildings, the boom proves to have very good slip properties. The five arms make it easy to reach a wide variety of positions on the construction site. The design and kinematics of the boom ensure low-vibration and even work when placing concrete.

The shape of the charging hopper favours a uniform flow of concrete and very good suction behaviour. Two separately driven agitators push the concrete directly into the suction area, which works perfectly even with concrete types that are difficult to pump.

Unique Powerbloc drive unit

A major highlight of the new 36 XXT is Liebherr's newly developed "Powerbloc" pump drive unit. It is characterised by the fact that all hydraulic switching and measuring elements are fully integrated. This eliminates the need for numerous hydraulic hoses and other components previously required. The drive unit is therefore a special kind in the concrete pump world. Features of the new system are its robustness, high performance and quiet running.

Semi-closed oil circuit (HCC)

The new drive unit is combined with the highly efficient semi-closed oil circuit, which supplies all drives powerfully and reliably with hydraulic energy. As a result, the oil volume could be significantly reduced. The new Liebherr system combines the advantages of the proven open and closed circuits currently on the market, without their respective disadvantages. Customers confirm the quiet and powerful operation of the pump unit.

Thanks to the extensive accessories catalogue, no wishes remain unfulfilled for the customer: For example, state-of-the-art LED lighting designs for optimal work in the dark, various storage boxes for materials and tools as well as shelves for extension hoses are available.

About the Liebherr Group

The Liebherr Group is a family-run technology company with a broadly diversified product range. The company is one of the largest construction machinery manufacturers in the world, but also offers high-quality, benefit-oriented products and services in many other areas. Today, the group comprises more than 140 companies on all continents, employs around 48,000 people and generated a consolidated total turnover of more than 10.3 billion Euros in 2020. Since its foundation in 1949 in Kirchdorf an der Iller in southern Germany, Liebherr has pursued the goal of impressing its customers with sophisticated solutions and contributing to technological progress.

Images



liebherr-pump-36-XXT.jpg

The new truck mounted concrete pump 36 XXT is a real all-rounder.

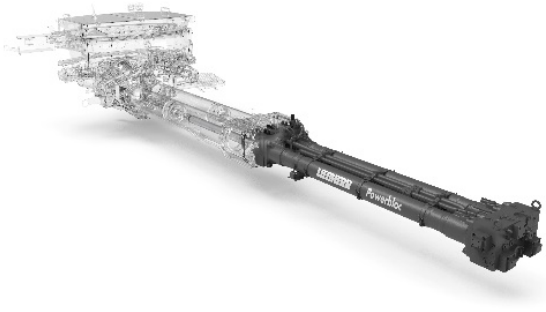

liebherr-powerbloc.jpg

The powerful Powerbloc pumping unit stands out with its quiet running.

Contact person

Klaus Eckert

Telephone: +49 7583 949-328

E-mail: klaus.eckert@liebherr.com

Published by

Liebherr-Mischtechnik GmbH

Bad Schussenried / Germany

www.liebherr.com