

Press release

# **New 36 XXT truck-mounted concrete pump from Liebherr: light, compact and flexible**

- **36 metre boom as a five sections folding boom in a new design**
- **Unique Liebherr Powerbloc drive unit**
- **Semi-closed oil circuit offers many advantages**

**Innovative technologies have been combined in a compact machine: The new 36 XXT truck-mounted concrete pump combines the advantages of the new five-fold placing boom with the Powerbloc drive unit and the semi-closed oil circuit. The whole thing has also been given a new and attractive look.**

Bad Schussenried (Germany), 18 January 2024 - After extensive test series, sales of the completely newly developed truck-mounted concrete pump 36 XXT from Liebherr have started. The result: a real all-rounder, packed with technical innovations from Liebherr. Many of the pump operators wishes were taken into account, such as ergonomic access steps, simplified accessibility and an expansion of the stowage and storage options.

An extremely compact superstructure without a boom overhang at the rear ensures high manoeuvrability in confined areas. The machine is weight-optimised and, depending on the equipment, has a total weight of around 26 tonnes on three axles. The XXT support ensures better stability. It really comes into its own when it comes to narrow supports, so confined spaces are no problem. The modern radio remote control allows sensitive boom movements. The clear colour display shows the operator all the important parameters.

## **The five section boom allows a great deal of flexibility and even working when paving concrete**

The new five arms boom allows maximum flexibility on the construction site. The boom has special slip properties, especially when concreting in buildings. The five arms boom make it easy to reach a wide variety of positions on the construction site. The design and kinematics of the boom ensure low-vibration and even working during concrete placement. The shape of the feeding hopper favours an even flow of concrete and good suction behaviour. Two separately driven agitators push the concrete directly into the suction area, which works perfectly even with concrete types that are difficult to pump.

## Unique Powerbloc drive unit

A key highlight of the new 36 XXT is the newly developed "Powerbloc" pump drive unit from Liebherr. It is characterised by the fact that all hydraulic switching and measuring elements are fully integrated. This eliminates the need for numerous hydraulic hoses and other components that were previously required. This makes the drive unit a speciality in the world of concrete pumps. The new system is characterised by its robustness, high performance and smooth running.

## Hydraulic half close circuit (HCC)

The new drive unit is combined with the highly efficient hydraulic half closed circuit, which supplies all drives powerfully and reliably with hydraulic power. As a result, the oil volume could be significantly reduced. Liebherr's new proprietary system combines the advantages of the proven open and closed circuits on the current market without their respective disadvantages. Customers confirm the quiet and powerful operation of the pump unit. Thanks to the extensive catalogue of accessories, nothing is left to be desired: For example, ultra-modern LED lighting concepts for problem-free working in the dark, various storage boxes for materials and tools as well as shelves for extension hoses are available.

## About Liebherr-Mischtechnik GmbH

Liebherr-Mischtechnik GmbH is a global manufacturer and supplier of high-quality concrete mixing plants, concrete pumps and ready-mix truck mixers. The company belongs to the Liebherr Group and is based in Bad Schussenried, Germany.

## Pictures



liebherr-pump-36-XXT.jpg

The newly designed truck-mounted concrete pump 36 XXT with its five-part placing boom is a real all-rounder.

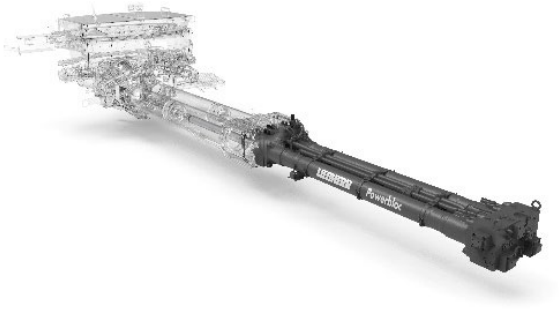

liebherr-powerbloc.jpg

The powerful Powerbloc pump unit impresses with its smooth running.

### **Contact person**

Klaus Eckert

Phone: +49 7583 949-328

E-mail: [klaus.eckert@liebherr.com](mailto:klaus.eckert@liebherr.com)

### **Published by**

Liebherr-Mischtechnik GmbH

Bad Schussenried, Germany

[www.liebherr.com](http://www.liebherr.com)