

Product Catalogue  
**Slewing Bearings**

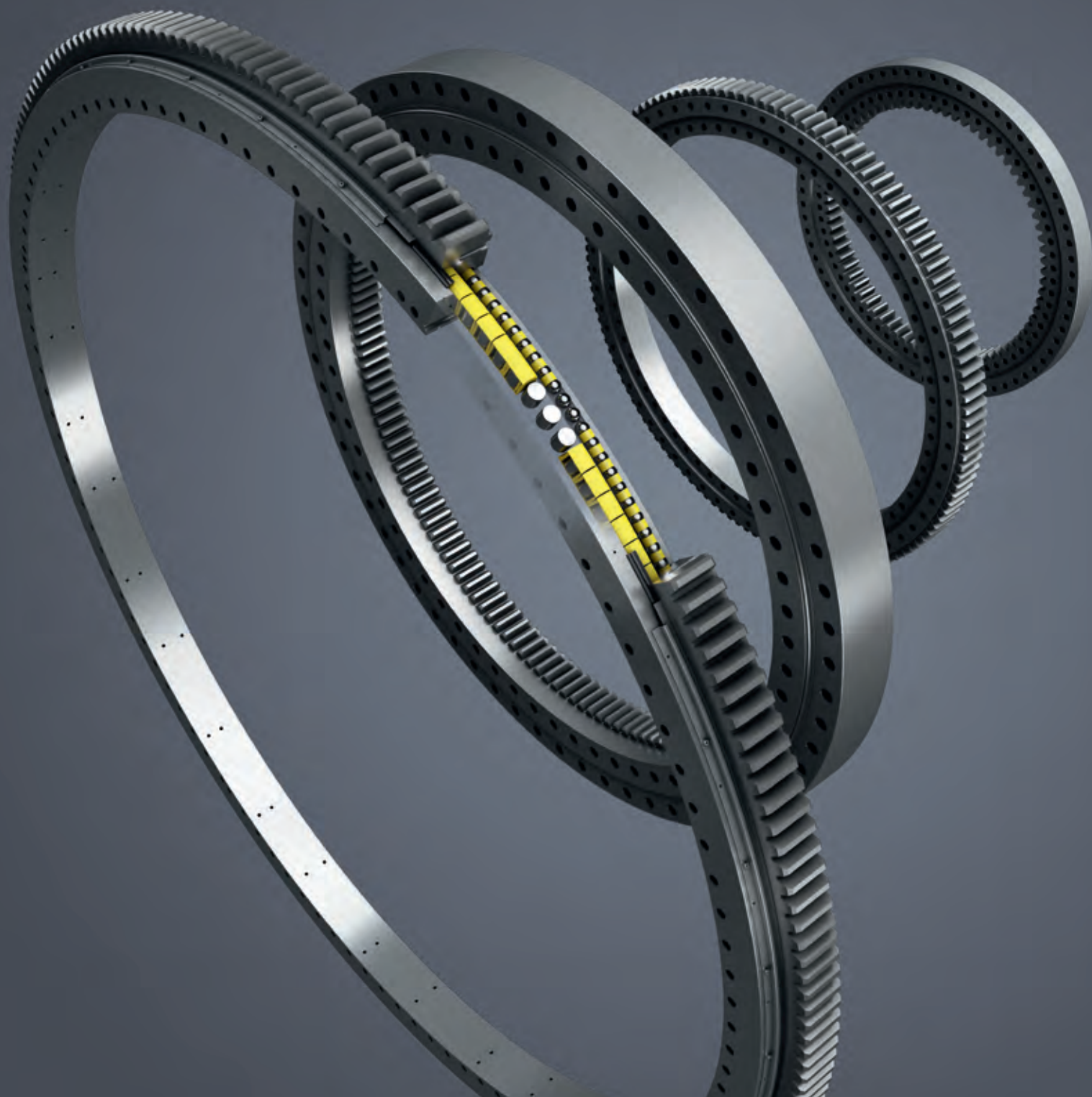

**LIEBHERR**

# Foreword and Disclaimer

This product catalogue provides information on the comprehensive, standard range of Liebherr slewing ring bearings for diameters between 31.5 in and 236 in. Diameters out of this range are available on request.

The content of this catalogue was compiled with the utmost care. However, no responsibility can be taken for the correctness, completeness and topicality of the disclosed information.

We reserve the right to make changes resulting from the further development of the product range.

All texts, images, graphics, tables or other diagrams, and their arrangement, are protected by law (Copyright © Liebherr-Components AG, all rights reserved). The content of the catalogue must not be copied, disseminated, modified or made accessible to third parties for commercial use without the express written consent of Liebherr-Components AG. Some of the images shown in this catalogue are subject to third-party copyright.

For the latest version of the Large Diameter Bearing Product Catalogue by Liebherr, please visit [www.liebherr.com/components-downloads](http://www.liebherr.com/components-downloads).

Please contact us for further information.

Publisher:

Liebherr-Components AG  
Postfach 222  
CH-5415 Nussbaumen / AG  
Switzerland  
Tel.: +41 56 296 43 00  
Fax: +41 56 296 43 01  
E-mail: [components@liebherr.com](mailto:components@liebherr.com)  
[www.liebherr.com](http://www.liebherr.com)

Copyright © May 2017  
by Liebherr-Components Biberach GmbH, Biberach an der Riß

# List of content

1	High-quality slewing bearings for all applications	4
2	Overview of bearing types	11
3	Structure of four-point bearings and roller bearings	14
4	Materials	16
5	Raceway	18
6	Seals	19
7	Bolt	20
8	Gearing	22
9	Geometric properties	25
10	Surface coating and corrosion protection	27
11	Operating temperature	29
12	Requirements of adjacent construction	29
13	Influence of adjacent construction – $K_{rep}$ factor	32
14	Finite Element Method	33
15	Assessment of the adjacent construction by Liebherr	35
16	Bearing mounting	36
17	Production	45
18	Lubrication	48
19	Packaging, transportation and storage	53
20	Control/Inspection	54
21	Bearing selection	58
22	Dynamic bearing service life	65
23	Rotation resistance of bearing	68
24	Drive torque required	70
25	Glossary	72
	Overview standard range	73
26	Technical data, Overview KUD_V Ball bearings; four-point contact	75
	Technical data, Overview KUD_Z Double-row ball bearings	101
	Technical data, Overview KUD_W Double-row ball bearings; four-point contact	111
	Technical data, Overview ROD_D Triple-row roller bearings*	129
	Technical data, Overview ROD_D Triple-row roller bearings	135
	Technical data, Overview RKD Combined roller and ball bearings	147
	Further information	154

# 1 High-quality slewing bearings for all applications

Liebherr is one of the leading global manufacturers of slewing bearings and has over 60 years of experience in the development, design and manufacturing of ball and roller bearings. Customers appreciate in particular the large product range, application-specific development and outstanding quality of large diameter bearings from Liebherr.

## Extensive product portfolio

The current product range includes slewing ring bearings which may be single- or double-row four-point contact, triple-row roller or a combination of both ball and roller elements. In addition to standard types, a variety of customised and application specific special designs are available.

Liebherr manufactures slewing bearings for a wide range of applications. Liebherr can manufacture the bearing with external, internal or no gearing. The gears are available in common or uncommon modules.

## Versatile applications

The areas of application in which the large diameter bearings from Liebherr are used are as diverse as the designs. These include construction machines such as excavators and drilling rigs, mining equipment, cranes such as construction, mobile and offshore, maritime applications, vehicles, machine tools and wind turbines.

## System solutions from a single source

Liebherr provides system solutions from a single source. The slewing bearings are ideally combined with slewing drives and swivelling drives from Liebherr. Upon request, electric or hydraulic motors, as well as control technology, are also available as complimentary components. The selection is thus made simply and quickly for our customers.



Combination of slewing bearing and slewing drive



Combination of slewing bearing and swivelling drive

# Quality and reliability

All components satisfy the very highest standards with respect to functional reliability and durability, even under extreme loads. World-class quality management and extensive analysis and test procedures are practised throughout the entire development and production process, guaranteeing reliability and long component service life.

## Consistent quality management

Excellent quality is a trademark of Liebherr products. The quality management of Liebherr-Components Biberach GmbH is certified according to DIN EN ISO 9001. To achieve and maintain these high standards, Liebherr uses advanced Finite Element Methods (FEM) as well as Failure Mode Effects Analysis (FMEA). These high standards also continue with the choice of suppliers and through after-sale service.

All production and assembly processes are documented in a computer-supported operating data recording system. This is also used as a central quality management system that records production and assembly measurements. This allows comprehensive control, monitoring and traceability. The processes are continuously improved through diverse assessments.

## Highest quality of raw materials

All individual components of the large diameter bearings are selected according to the application, and are subject to the highest quality standards. Raw parts and components are only supplied from qualified suppliers, who are audited regularly. For certain raw materials, such as rolled steel rings, our own company standards apply which go beyond the common industry standards.



CMM machine for slewing bearings



Quality check of slewing bearings using UV light

**Use and features of application-specific materials**

The design of each large diameter bearing is largely determined by the expected environmental conditions. In this respect, in addition to the usual 42CrMo4 alloy, Liebherr also uses steels with adapted alloy components as a base material for bearings in low temperature applications. Upon request from the customer, bearing cages made from steel or brass alloys can also be used in place of polymer spacers. The special sealing systems and coatings for reliable protection against corrosion and increased wear are in constant further development by Liebherr. The lubrication ports are arranged as required and depend on the adjacent structure interface. Gearing is predominantly designed as spur gearing, but helical and worm gears are also possible.

**Certifications and classifications**

Often times, classifications and certifications are required by certified bodies for specific applications. Some examples of these certifications are:

- Det Norske Veritas - Germanischer Lloyd (DNV GL)
- American Bureau of Shipping (ABS)
- Bureau Veritas
- Lloyds Register of Shipping
- American Petroleum Institute (API)



Quality check of slewing bearings

Liebherr is able to look back on a long-term collaboration with the certification bodies, which is characterised by the certification of complete systems with Liebherr components.

Depending on the requirement of the test and documentation scope, various certificates are provided in accordance with EN 10204.

**For typical applications in machine and plant construction:**

- Certificate of Compliance 2.1
- Factory Certificate 2.2
- Acceptance Certificate 3.1

**For special requirements:**

- Acceptance Certificate 3.2

The certificates must be presented to the classification bodies within the framework of an inspection. If necessary, the certificates are provided by Liebherr.



Classification bodies

# Production and sales

The slewing bearings are manufactured at Liebherr locations in Biberach an der Riß (Germany), Monterrey (Mexico) and Guaratinguetá (Brazil). The sale of components to customers outside the Liebherr Group is managed centrally by Liebherr-Components AG in Nussbaumen, Switzerland. Our customers are managed centrally from there.

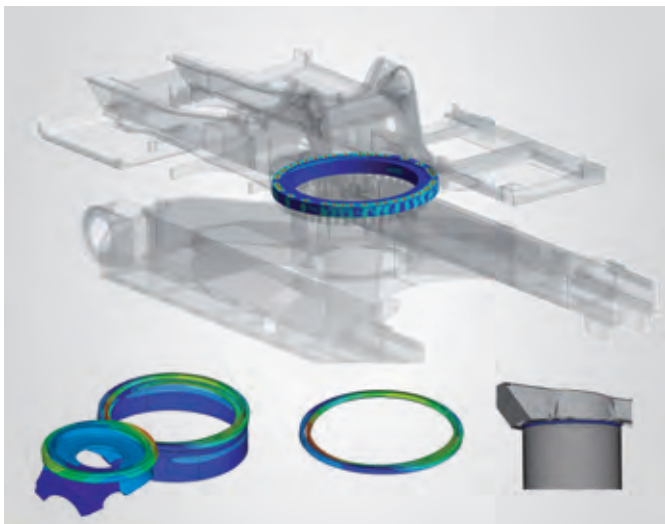

Finite Element Method



Spacers, rolling elements, seals and lubricant



Slewing bearing in production



Gear milling

# Production sites

## Liebherr-Components Biberach GmbH

Liebherr-Components Biberach GmbH develops and manufactures high-performance components – such as electric machines, gearboxes and slewing bearings, rope winches and switchgears – both for the Liebherr Group and for external customers. The large diameter bearings supplied from Biberach are used in construction machines such as excavators and drilling rigs, mining equipment, cranes, maritime applications, vehicles, machine tools or wind turbines.

### Facts and Figures:

- Founded: 1954 as Liebherr-Werk Biberach GmbH (foundation of Liebherr-Components Biberach GmbH in 2012)
- No. of employees: 1,430
- Plant premises: 414,788 yd<sup>2</sup>
- Constructed area: 127,626 yd<sup>2</sup>



Liebherr-Components Biberach GmbH, Germany

## Liebherr Monterrey, S. de R.L. de C.V

The production company Liebherr Monterrey, S. de R.L. de C.V. manufactures high-quality and efficient single-row and multi-row ball and roller bearings as well as special rings in diameters up to 138 in. These products are mainly used in wind turbines, construction machines and maritime applications, but also in mining equipment, vehicles or machine tools.

### Facts and Figures:

- Founded: 2009
- No. of employees: 140
- Total area: 358,796 yd<sup>2</sup>
- Constructed area: 107,639 yd<sup>2</sup>



Liebherr Monterrey, S. de R.L. de C.V, Mexico



### **Liebherr Brasil Ltda.**

Liebherr Brasil Ltda. manufactures excavators, wheel loaders, tower cranes, stationary mixing plants and truck mixers, as well as maritime cranes. The company also organises the sales, technical customer services and spare parts supply for other product lines of Liebherr in Brazil. Starting in 2016, large diameter bearings up to 177 in are being produced for use in wind turbines and industrial applications.

### **Further information**

Visit our website [bearings.liebherr.com](http://bearings.liebherr.com) and find out more about our products, current events, news and points of contact.

#### **Facts and Figures:**

- Founded: 1974
- No. of employees: 1,090
- Total area: 1,137,907 yd<sup>2</sup>
- Constructed area: 67,779 yd<sup>2</sup>



Liebherr Brasil Ltda. in Guaratinguetá, Brasil



## 2 Overview of bearing types

### Standard types



Single-row four-point bearings – with external gear



Single-row four-point bearings – with internal gear



Double-row four-point bearings – with external gear



Double-row four-point bearings – with internal gear

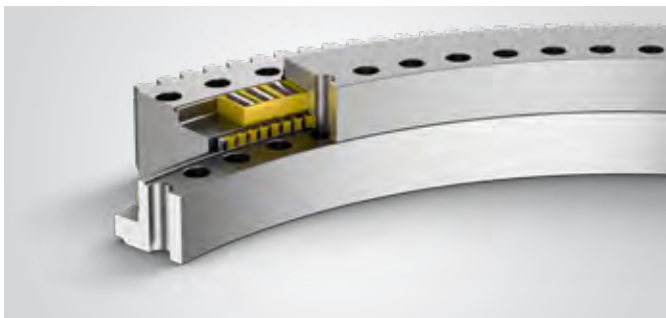

Triple-row roller bearings – with external gear



Triple-row roller bearings – with internal gear



Double-row ball bearings (double, axial ball bearings, double thrust bearings) – with external gear/with internal gear/no gear



Combined roller and ball bearings – with external gear/with internal gear/no gear

## Other types



Cross roller bearings –  
with external gear/with internal gear/no gear



Radial bearings –  
with external gear/with internal gear/no gear



Roller bearings with bolt connection –  
with external gear/with internal gear/no gear



Roller bearings with bayonet joint –  
with external gear/with internal gear/no gear



Tapered roller bearings –  
with external gear/with internal gear/no gear



Single-row four-point bearings with special seals –  
with external gear/with internal gear/no gear



Double-row four-point bearings with special seals –  
with external gear/with internal gear/no gear

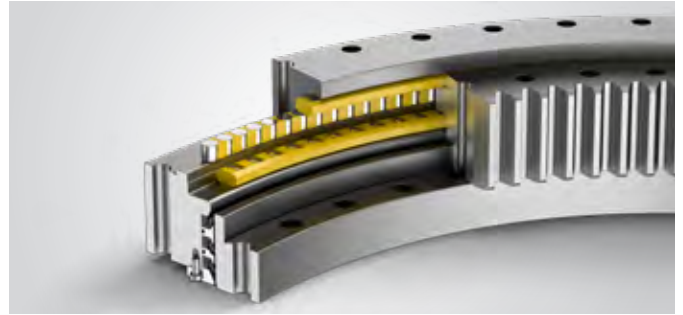

Triple-row roller bearings with special seals –  
with external gear/with internal gear/no gear

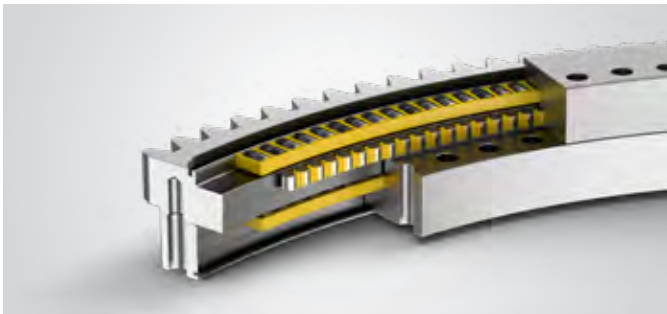

Segmented bearings with induction hardened raceways –  
with external gear/with internal gear/no gear

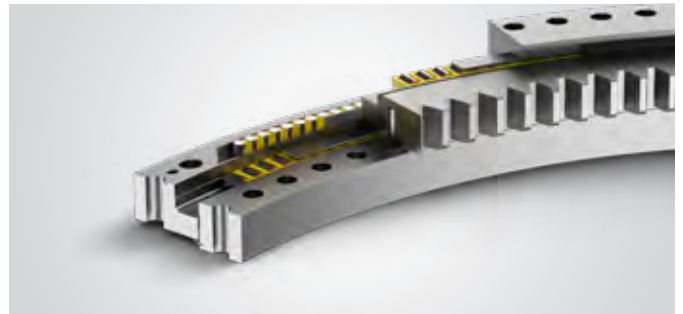

Segmented bearings with hardened insertion plates –  
with external gear/with internal gear/no gear with insertion plates



Gear rings –  
with external gear/with internal gear

# 3 Structure of four-point bearings and roller bearings

## ■ Cross-section through a four-point bearing with external gear

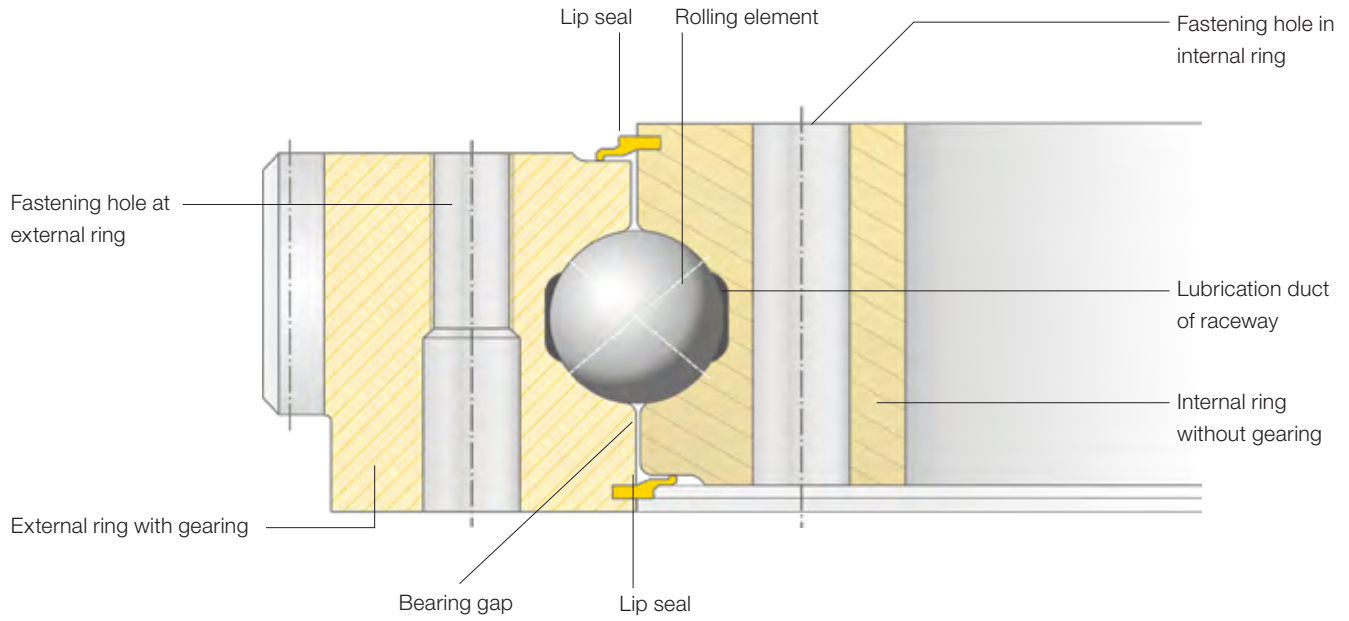

## Cross-section through triple-row roller bearing with internal gear

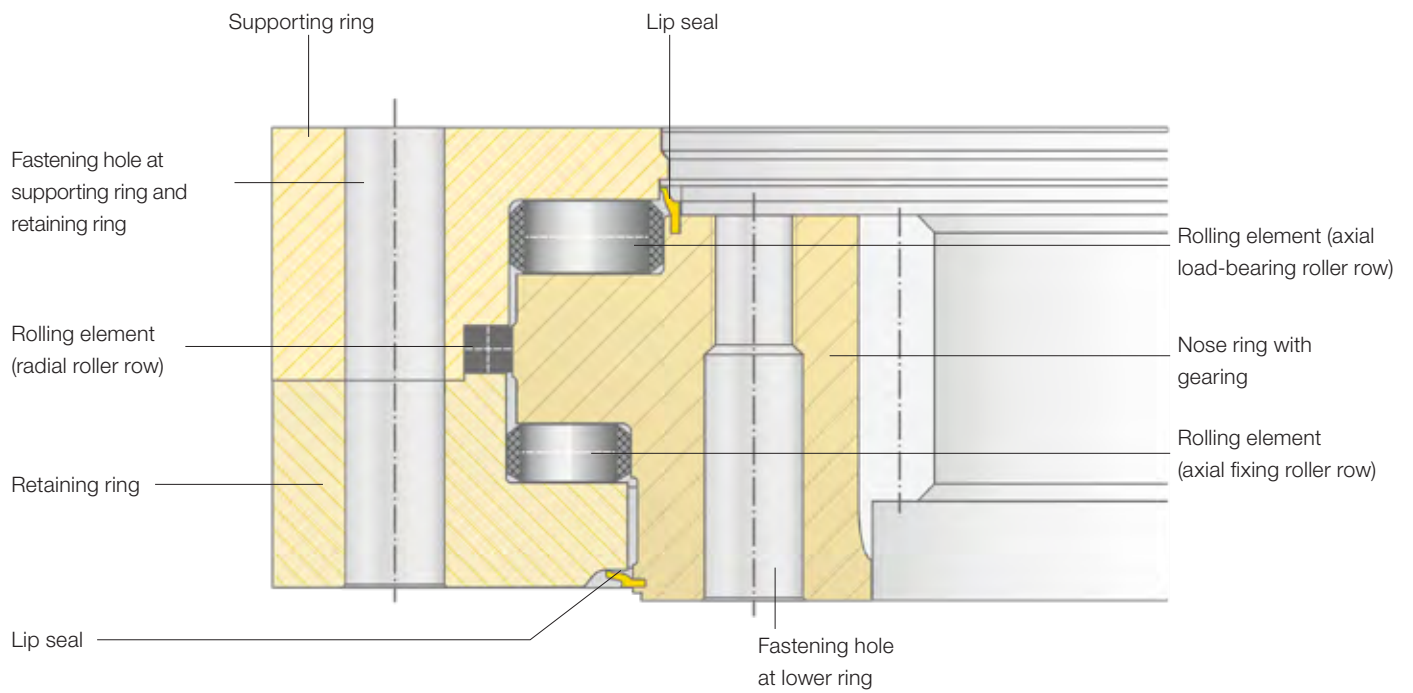

## 4 Materials

### Bearing rings

Different materials are used for the bearing rings depending on the application and purpose of the Liebherr large diameter bearing. These are made from tempered alloy steel as standard, which is specified by our own company standards (LN), derived from DIN EN 10083-1. For applications needing additional properties, special materials are used such as chrome-nickel steels for low temperature environments.

The chemical composition, handling of the material during the formation of the raw parts, and the mechanical properties of the basic material through to the EN requirement are stipulated in the company standards. To ensure consistent quality,

each raw part is monitored during the manufacturing process based on test criteria, which are defined in the Liebherr standard. Regular audits at the suppliers ensure compliance with the delivery specifications.

Depending on the requirement of the test and documentation scope, various certificates are provided for the raw parts in accordance with DIN EN 10204.

Upon request, all documents required for the certification or classification of components or systems are provided.

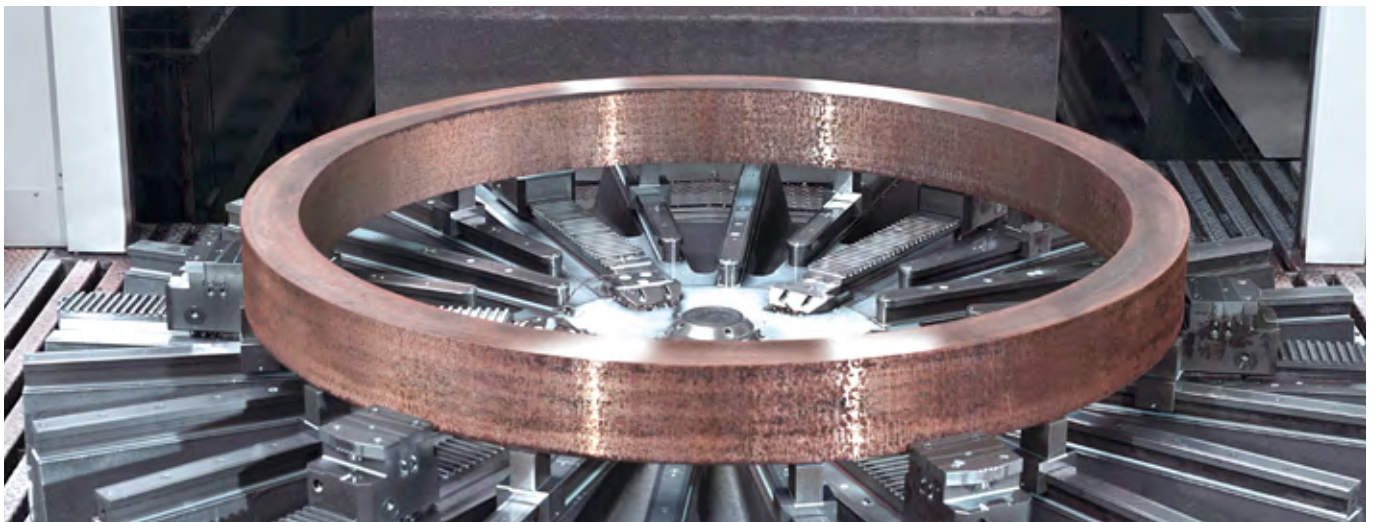

Rolled ring on turning machine



## Rolling element

Only balls and rollers made from hardened anti-friction bearing steel are used as rolling elements. The material is specified in our own company standards based on DIN 5401, DIN 5402 and ISO 3290-1. The chemical composition and the properties of the material are prescribed via the requirement of DIN/ISO.

To ensure consistent quality, each production batch is monitored during the manufacturing process based on defined test criteria.

Regular audits at the suppliers ensure compliance with the delivery specifications.

## Spacers

The spacers and roller cages are made from specially developed polyamide and are responsible for guiding the rolling elements and keeping them equidistant during rotation. Keeping the rolling elements from colliding will ensure reliable operation. Consistently high quality is ensured through regular mechanical material testing.

For special applications cages or cage strips made from metal and plastic can be used.



Rolling elements



Polymer spacers

## 5 Raceway

For the manufacture of the rolling element raceways, Liebherr relies on its in-house manufacturing expertise to machine the raceway contours.

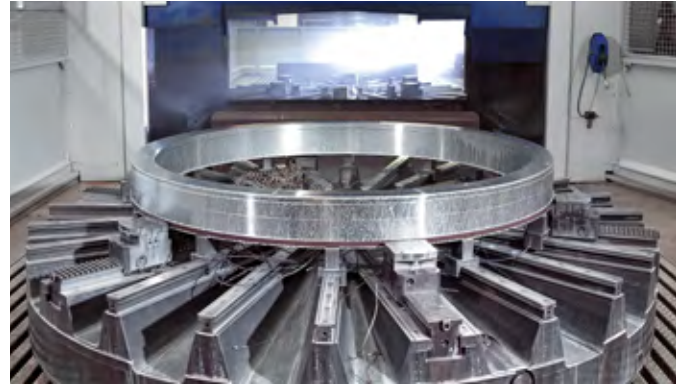

Manufacturing process - Turning

This is followed by the hardening of the raceway on separate induction hardening machines.



Grinding pattern of a ball bearing slewing ring with hardened case



Grinding pattern of a roller bearing slewing ring with hardened

To complete the raceway, it is ground after induction hardening to a surface finish of Ra 0.8 micrometers.

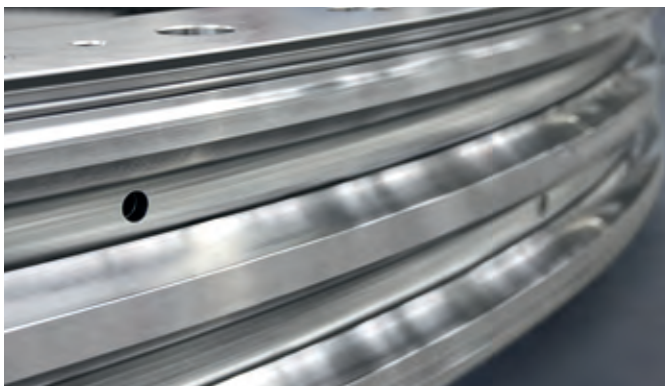

Fully processed ball raceway

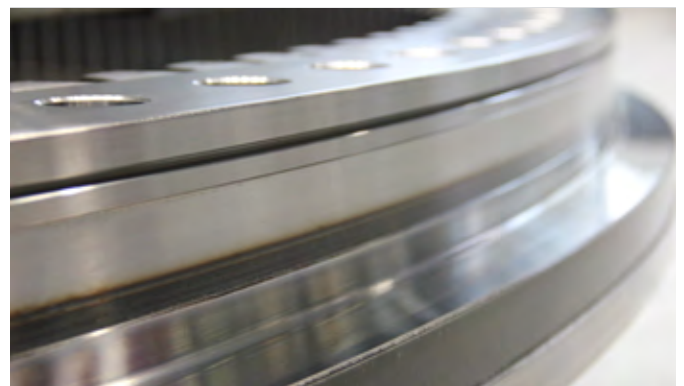

Fully processed roller raceway

# 6 Seals

Slewing bearings from Liebherr are mostly designed with lip seals on both sides of the raceway system. These mainly have two tasks to fulfil:

- They prevent direct entry of moisture, dust and other foreign particles from outside into the bearing gap.
- They separate the raceway system from the surrounding area.

Various types and materials of seals are available. The type and material of the seals depends on the geometry, application and surrounding environmental conditions of the bearing.

For applications in construction machines, as well as in general machine and plant construction, seals with a simple lip design have been highly successful. In special applications, however, different seal geometries are necessary. For example, a simple lip seal would not be effective in particle rich environments or keep grease from exiting the raceway.

Our seal materials are optimised in terms of the operating conditions. However, the seals are still subject to a certain amount of wear, for example by the effect of different environmental factors such as direct UV radiation and ozone influences. Therefore, they must be checked at regular intervals and replaced if necessary.

The surrounding area of the seals must be designed so that damage may not arise from assembly activities, or from the use of fastening tools.

It is also necessary to ensure during installation that an even grease collar is formed at the seal (see chapter 18 "Lubrication").

Examples for seals:

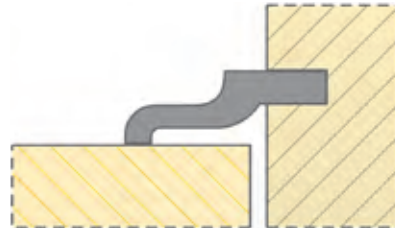

Lip seal

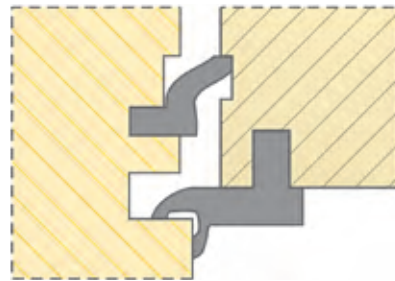

Double seal

# 7 Bolt

## Fastening bores

Fastening holes are available for securing the Liebherr slewing bearings at the adjacent construction. Depending on the application and the existing adjacent construction, they may either be designed as through or blind holes with all common thread types.

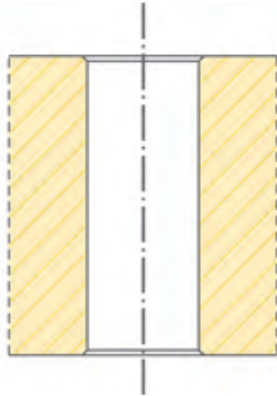

Through hole

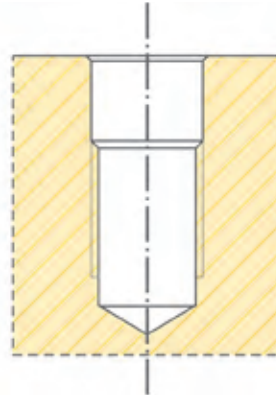

Blind threaded hole

At the execution of the securing as a blind threaded hole, the thread is free drilled in most cases, to achieve the greatest possible grip length of screwing. In principle, all bore hole types are possible upon request.

### Through holes for metric threads

Metric ISO thread i.a.w. DIN 13-1	M10	M12	M14	M16	M18	M20	M22	M24	M27	M30	M33	M36	M39	M42	M45	M48	M52	M56	M60	M64
Through holes (DIN EN 20273, tol.cl. medium)	11	13.5	16	17.5	20	22	24	26	30	33	36	39	42	45	48	52	56	62	66	70

### Through holes for imperial threads

Thread size of through hole i.a.w. ASME B18.2.8-1999, R2005	Through hole [Inch]	Through hole [mm]
<b>7/16" – 14 UNC</b>	15/32	12
<b>1/2" – 13 UNC</b>	9/16	14.5
<b>5/8" – 11 UNC</b>	11/16	17.5
<b>3/4" – 10 UNC</b>	13/16	21
<b>7/8" – 9 UNC</b>	15/16	24
<b>1" – 8 UNC</b>	1 3/32	28
<b>1 1/8" – 7 UNC</b>	1 7/32	31
<b>1 1/4" – 7 UNC</b>	1 11/32	34
<b>1 3/8" – 6 UNC</b>	1 1/2	38
<b>1 1/2" – 6 UNC</b>	1 5/8	41

## Lubrication ports

Lubrication ports are available for lubricating the bearing raceway. Depending on the installation conditions, these are either arranged radially or axially and have a M10x1 thread as standard and are also sealed with a plastic plug.

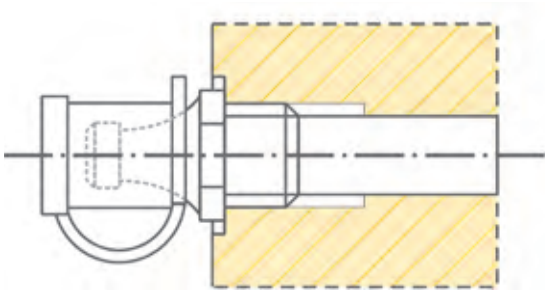

Lubrication port with threaded nipple

Lubrication lines for central lubrication systems, lubricating nipples or continuous lubricant dispenser can be connected at the lubrication ports.

Upon request, conical grease nipples i.a.w. DIN 71412 Form A M10x1 can be mounted at the factory. The threads of the conical grease nipples are designed i.a.w. DIN 158 "M10x1 con. short version". These have plastic lids to provide protection against damage and dirt contamination.

Other lubrication ports such as flat lubricating nipples, imperial threads or other design sizes are available by request.

# 8 Gearing

Liebherr slewing bearings can be manufactured with internal and external gears. Both are mainly designed as a spur gearing. Special gearing, such as helical and worm gearing, are also available upon request. All our bearings are also available without gearing.



Gear milling

## Diametral Pitch

Diametral Pitch, Pd, is the number of teeth per inch along the pitch circle diameter. It can be represented as follows for general pinions/and gears (d, z):

Conversion: Module to Diametral Pitch

$$P_d = \frac{z}{d} \quad \begin{array}{l} (z = \text{number of teeth}) \\ (d = \text{pitch circle diameter}) \end{array}$$

$$m = \frac{25.4}{P_d} \quad (m = \text{module})$$

## Module

The module, m, depicts the size of the gear teeth. It is defined as the amount of circular pitch, p, per tooth. Module is related to pitch as follows: p and pi π:

$$m = \frac{p}{\pi} \quad \begin{array}{l} (p = \text{circular pitch}) \\ (\pi = \text{circular number}) \end{array}$$

or alternatively as the ratio of pitch circle diameter d and number of teeth z.

$$m = \frac{d}{z} \quad \begin{array}{l} (d = \text{pitch circle diameter}) \\ (z = \text{number of teeth}) \end{array}$$

### Preferred module dimensions

Module in mm according to preferred dimensions   i.a.w. DIN 780	1	1.25	1.5	2	2.5	3	4	5	6	8	10	12	16	20	25	32	40	50

## Design and quality of the gearing

The standard version of the gearing is effected with involute toothing i.a.w. DIN 867 with the standard pressure angle  $\alpha = 20^\circ$ .

To optimise the gearing, profile displacement and modification of the root rounding are performed. I and II are used for the reference profile i.a.w. DIN 3972. Addendum reductions are also possible.

By default, the gear cutting quality of all Liebherr large diameter bearings is Q12:

- upper **tooth thickness**  $A_{sne}$  i.a.w. DIN 3967 (table 1) i.a.w. **deviation series b-e**.
- **Tooth thickness tolerance**  $T_{sn}$  i.a.w. DIN 3967 (table 2) i.a.w. **tolerance series 26-28**.

Other qualities or tolerance zones can be implemented upon request.

## Design and calculation of gearing

The strength of the gearing is generally checked in accordance with ISO 6336. Here, the technical data such as dimensions, number of teeth, profile displacement, as well as material properties of the drive pinion, are taken into account.

## Hardening of gearing

In most cases, the gear teeth are left in the natural state as the ring itself. The strength properties of the gear teeth are that of the base material. If the application calls for additional strength and wear properties, the gear teeth will undergo induction hardening. The hardening of the teeth will increase the wear and strength properties to the desired level.

Depending on the pitch circle diameter and module of the gearing, the teeth are treated by inductive hardening or spin hardening. In order to avoid metallurgical notches in the transition zone to the unhardened material, the teeth are hardened predominantly in the root of each tooth.

As well as improved flank load capacity, increased strength at the tooth root is also achieved.



Hardening microsection of tooth spacing hardening

## Backlash

By adjusting the backlash between the teeth of the pinion and the teeth of the bearing, constraints of the gear pairing are avoided during operation.

With a fitted bearing, the backlash should not fall below the value of  $0.03 \dots 0.04 \times \text{module}$  at the point of the maximum eccentricity of the gearing. For this purpose, this point is marked with a corresponding symbol:

- **External gears:** Symbol  $\oplus$   
(largest available pitch circle diameter),
- **Internal gears:** Symbol  $\ominus$   
(smallest available pitch circle diameter).

The teeth on the left and right are marked in red.

The backlash can be adjusted by the following two measures:

- Move the large diameter bearing within the tolerances of the fastening holes
- Eccentric fastening of the drive pinion to change center distance at those teeth

The setting must be checked again after the fastener connection is tightened.

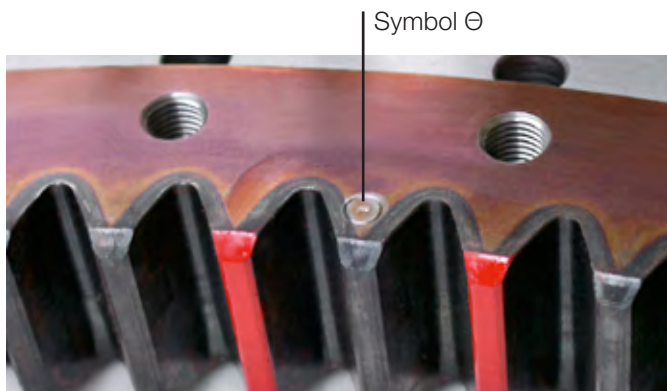

Marking of point of maximum eccentricity for internal gear

## Drive pinion

With a recommended profile displacement of

$$V_{A,\text{pinion}} = +0.5 \times m$$

the number of teeth of the pinion should not be below twelve teeth.

The gearing width of the pinion should project over the tooth width of the bearing on both sides by approx.  $0.5 \times \text{module}$ .

The gear cutting quality of the drive pinion is adapted to the application (at least gear cutting quality **Q9**):

- Upper tooth thickness  $A_{sne}$  i.a.w. DIN 3967 (table 1) according to **deviation series b-e** and
- tooth thickness tolerance  $T_{sn}$  i.a.w. DIN 3967 (table 2) according to **tolerance series 26-28**

An addendum chamfer is therefore essential. Tip relief and flank line correction are recommended.

Tooth corrections are determined by Liebherr upon request.

We recommend a surface hardness of at least  $HV_{\min} = 675$  at the pinion gearing. If a separate gearing calculation was performed, the hardness values must be taken from the calculation.

If a Liebherr slewing drive is also ordered for the bearing, Liebherr assumes the entire coordination of the components.



## 9 Geometric properties

### Permissible dimensional deviations

#### Diameter tolerance of bearing, general tolerances

Outer and inner diameter [inch]	Tolerance range [inch]
15.7 to 39.3	± 0.031
39.3 to 78.7	± 0.047
78.7 to 157.5	± 0.079
157.5 to 236.2	± 0.118
> 236.2	± 0.157

#### Position tolerance of fastening holes

Nominal thread dimension or bore hole diameter	Permissible dimensional deviations i.a.w. Liebherr company standard LN 28-1 [inch]
M6	Ø 0.0079
< M10	Ø 0.0118
< M16	Ø 0.0197
< M24	Ø 0.0276
< M42	Ø 0.0394
≥ M42	Ø 0.0512

### Run-out deviation of gearing

The run-out of the gearing depends on the play and run-out of the race-way system, in addition to the run-out deviation prescribed by the gearing standard

## Bearing clearance

Liebherr slewing bearings already have a precisely defined bearing clearance set ex works. This guarantees good running characteristics and the functional reliability of the bearing.

Constrictions in the raceway system, caused by possible deviations from the projection of the adjacent construction, may lead to constraints of the raceway system. As a result, it may cause stiffness and impermissibly high loads on the rolling elements and the raceway.

The play is adapted according to the application. Depending on the operating conditions, the bearing clearance may change during the operating time due to mechanical wear of the raceways and the rolling elements. The wear limit is reached from a certain dimension. It is dependent on the type and size of the bearing and the application. The bearing then has to be replaced.

### Standard Liebherr bearing clearance

Bearing type	Bearing clearance when delivered [inch]
Ball bearing	0.0 to 0.0197
Roller bearing	0.0 to 0.0197

## Bearing preload

For special requirements, for example in hydraulic excavators or wind turbines, bearings are customised to the respective application. They are also manufactured with a defined preload of the bearing raceways.

A bearing with play only has small frictional resistance. With the preload of the bearing raceways, the frictional resistance of the bearing increases, and then some when under load.

### **This must be taken into consideration in the design of the drive!**

Furthermore, false brinelling is effectively prevented by the preload. False brinelling is mainly caused by constant vibrations when the bearing is at a standstill and leads to a reduction in the service life.

For bearings with different temperatures between external and internal ring the bearing clearance is set specifically.

# 10 Surface coating and corrosion protection

Liebherr slewing bearings can be coated to protect the outer metallic ring surfaces against corrosion. Various technologies are used here in accordance with DIN EN ISO 12944 and DIN EN ISO 2063.

Corrosion inhibiting wax or Liebherr base coat (primer) can be used.

## Cleaning and blasting

Surfaces or prior coatings must be cleared of contaminants such as dust, grease, oil, salt or other dirt before the coating. All parts to be treated are cleaned thoroughly using a cleaning agent, degreased and dried with oil-free air. The wait time between cleaning and blasting is between two and four hours. The thermal spray process with zinc (TSC) is effected in accordance with DIN EN ISO 2063.

If the Liebherr primer is used, there is no need to remove the protective wax film.

## Corrosion categories

### Classification

Corrosion category	Requirement	Ambient conditions
C1	insignificant	–
C2	weak	Atmosphere with little pollution
C3	moderate	Urban atmosphere and industrial climate, moderate pollution by sulphur dioxide (IV); coastal areas with low salt concentration
C4	strong	Industrial climates and coastal areas with moderate salt concentration
C5-M	very strong	Coastal and offshore areas with high salt concentration

### Layer structure

Corrosion category	Designation	Layer thickness [μ inch]
C1	1. GA1	1.9685
	Total	1.9685
C2	1. GA1	1.9685
	1. DA2	3.1496
	Total	5.1181
C3	1. GA1	3.5433
	1. DA2	2.7559
	Total	6.2992
C4	1. GA1	3.1496
	2. GA1	4.7244
	1. DA2	3.1496
	Total	11.0236
C5-M	1. GA1	3.1496
	2. GA1	6.2992
	1. DA2	3.1496
	Total	12.5984

GA1 = Primer

DA2 = Topcoat

## Thermal zinc spraying

Slewing bearings from Liebherr may also be protected with a special layer structure as an alternative to the standard layer structures shown in table "Layer structure". This surface protection achieves the protection class C5-M and thus corresponds to the highest protection needs.

The structure is made up of a combination of thermal zinc spraying (base coat) and paint (topcoat). As a base for the additional paint coating, the thermal zinc spraying i.a.w. DIN EN ISO 2063 provides additional cathodic corrosion protection of the surfaces by the "self-restoring" effect of the zinc layer in the event of damage.

Liebherr sets standards in terms of surface protection thanks to the use of state-of-the-art equipment technology in the coating of components.

If the large diameter bearings are not protected against corrosion with a surface coating, the outer surfaces of the large diameter bearing are treated with corrosion inhibiting wax. This must be removed before installation.

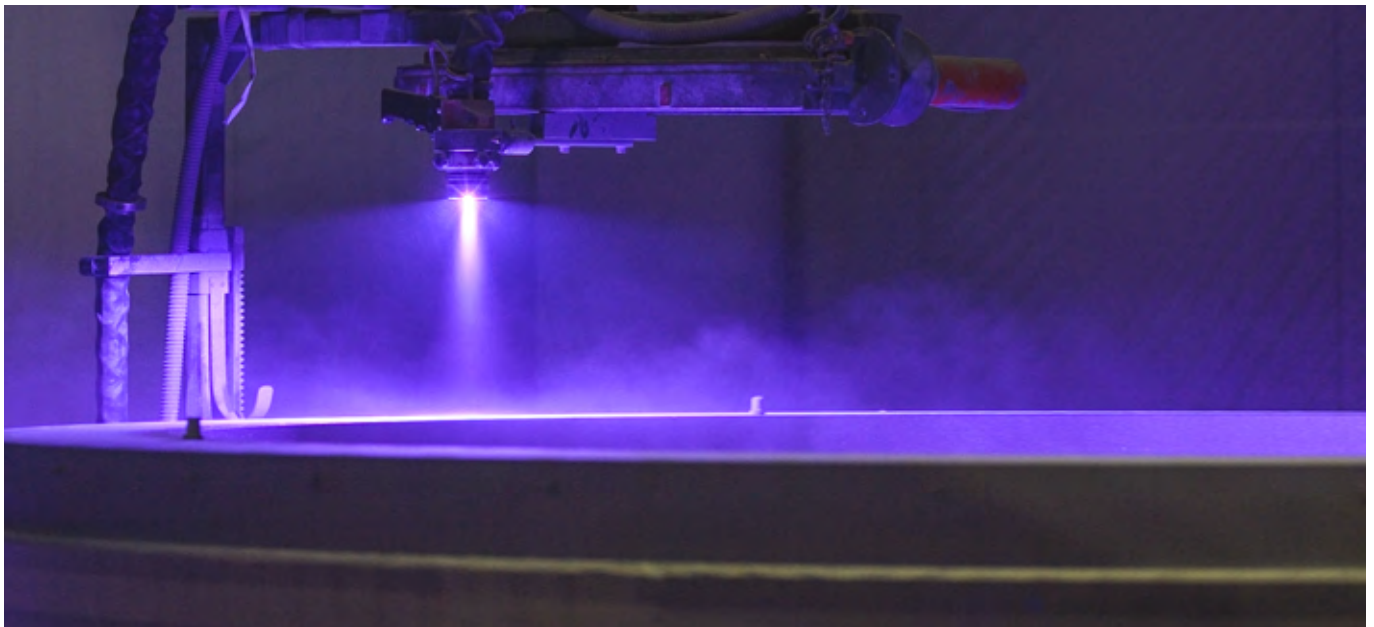

Thermal zinc spraying

# 11 Operating temperature

The standard version of Liebherr slewing bearings is suitable for operating temperatures between -22°F and 176°F.

If deviating operating or stagnation temperatures are planned or probable, the material properties and strength properties must be checked. This must be checked by Liebherr in each case.

# 12 Requirements of adjacent construction

## Ideal adjacent construction

In relation to its diameter, the cross-section of large diameter bearings is very small. Therefore, the inherent stability is significantly lower than the stability and stiffness of the adjacent construction.

As a rule, bearings are not suitable for compensating instabilities and deformations of the adjacent construction. This is why the adjacent construction must be as homogeneous and rigid as possible and the external forces must be transferred as evenly as possible to the bearing.

The bearing cannot be used to reinforce a structure! The average inner diameter of the adjacent structures diameter should be in the range of the raceway diameter.

## Mechanical processing of connection surfaces

To avoid additional stress on the raceway system, the connection surfaces must have certain dimensional tolerances (cf. tables p. 30).

The contact surfaces must be machined. Ensure that connection surfaces which are already machined are not damaged or deformed by subsequent machining processes.

In the case of welding work, warpage is to be expected due to the introduction of heat. The dimensional tolerances must be checked after machining and if necessary the contact surfaces must be reworked.

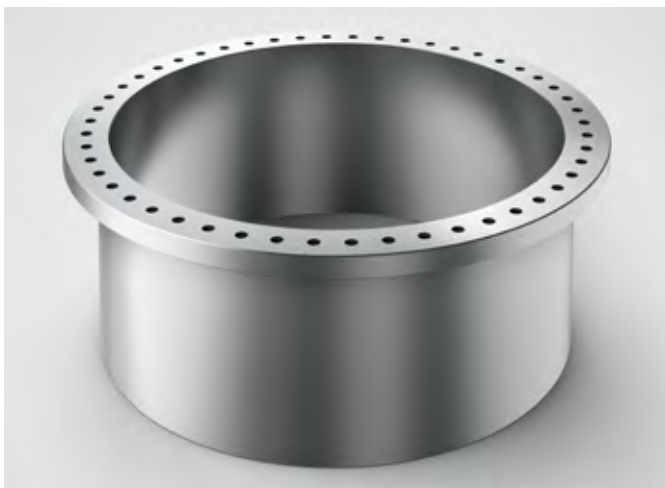

Ideal adjacent construction (homogeneous and rigid)

## Flatness of connection surfaces

In an unloaded state, the flatness of the connection surfaces cannot exceed the values in the tables listed below.

### Flatness tolerance for four-point ball bearings

Raceway diameter [inch]	Flatness tolerance i.a.w. DIN EN ISO 1101 in inch for four-point ball bearing
to 39.3	0.0059
to 59.1	0.0079
to 78.7	0.0091
to 98.4	0.0098
to 137.8	0.0118
to 177.2	0.0138
to 236.2	0.0157

### Flatness tolerance for roller bearing

Raceway diameter [inch]	Flatness tolerance i.a.w. DIN EN ISO 1101 in inch for roller bearing
to 39.3	0.0039
to 59.1	0.0051
to 78.7	0.0059
to 98.4	0.0071
to 137.8	0.0083
to 177.2	0.0098
to 236.2	0.0118

For a measurement length of 3.937 inch, measured at any point on the contact surface, a tolerance of 0.00197 inch is allowed.

The maximum value of the flatness deviation can only occur every 180°. The curve may only rise or fall evenly. If this requirement is satisfied, this does not have a significant effect on the service life of the bearing.

In order to balance corresponding unevenness, epoxy resin can be used, which is applied to the connection surfaces.

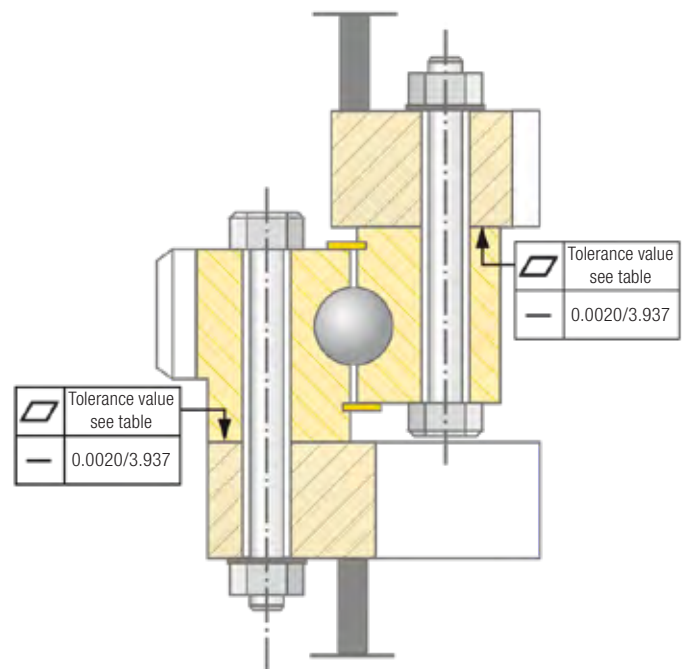

Flatness tolerances of connection surfaces

# Assembly and serviceability of the adjacent construction

## The following should be observed when designing the adjacent construction:

- The lubrication points of the bearing must be easily accessible.
- All fastening bolts must be easily accessible.
- Tightening and preloading using suitable devices must be possible without any obstructions (also for later checks and maintenance during operation).
- All bore hole patterns of connection surfaces and bearings are congruent.
- The through holes are designed according to DIN EN 20273 "medium".

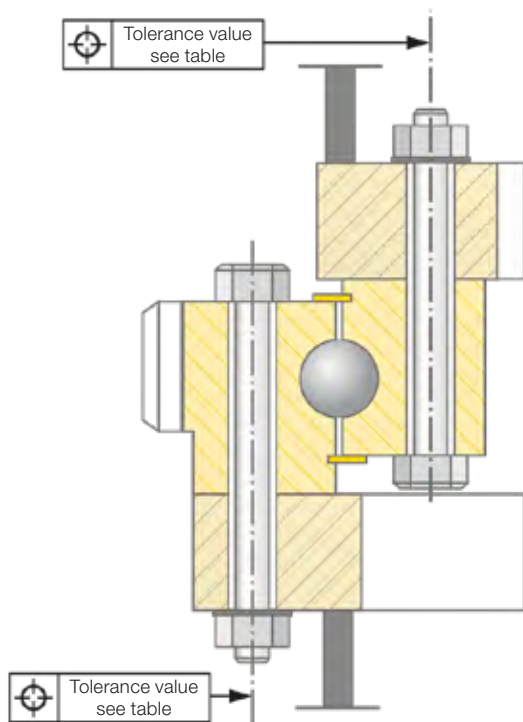

## Tolerances at bore hole pattern of connection surfaces

Thread sizes	Position tolerance [inch]
M6	0.0079
≤ M10	0.0118
≤ M16	0.0197
≤ M 24	0.0276
≤ M 42	0.0394
> M 42	0.0512

# 13 Influence of adjacent construction – $K_{rep}$ factor

The adjacent construction which surrounds the bearing is also a deciding factor for the function of a large diameter bearing. In order to take into account its influence in the analytical calculation, the  $K_{rep}$  factor is used. This should consider the increase in load resulting from the adjacent construction on the rolling element. The values result from the assessment/years of experience of FE analyses and serve as guide values. In case of doubt, the exact values for the corresponding application must be calculated with our design or calculation department.

These load increases may occur due to reinforcements which are unfavourable for the bearing and geometries in the adjacent construction. For example, this may be stiffening ribs for hydraulic cylinders for cranes or excavators.

## $K_{rep}$ factor for adjacent construction

Application (extract)	$K_{rep}$
Homogeneous and rigid adjacent construction (ideal)	1.0
Wind turbine blade bearing	1.2
Wind turbine yaw bearing	1.2
Rudder propeller yaw bearing (thruster)	1.2
Maritime cranes (e.g. offshore crane, ship crane)	1.2
Tower crane	1.3
Tunnel Boring	1.3
Conveying technology (e.g. stacker/reclaimer)	1.3
Plant construction (e.g. bottle filling plant)	1.3
Hydraulic excavator	1.8
Special vehicles (e.g. turntable ladder vehicle)	1.8
Mobile crane	3.0



# 14 Finite Element Method

The analytical calculation of Liebherr slewing bearings is used for the preliminary design using the present loads and the installation conditions.

For the detailed design the large diameter bearings are calculated using the Finite Element Method (FEM). The adjacent construction provided by the customer is included in the FE model. Only this way can the load state in the bearing be determined more realistically.

Depending on the requirement and application, there are two methods available:

## Method 1: In-house software "FastFEM"

With this software the bearing raceways of a large diameter bearing can be calculated in a short period with a high degree of automation.

### With this method the following parameters are considered in the FE model:

- Adjacent construction from customer
- Bearing rings without details
- Non-linear stiffness of rolling element
- Exact raceway geometry taking into account the profile of the rollers (only for roller bearings) or osculation and raceway ends (only for ball bearings)

### Results of FE calculation:

- Load distribution in bearing (force on rolling element)
- Pressure distribution in all rolling elements taking into account the tilting of the bearing raceways under load (only for roller bearings) or taking into account the force contact angle under load (only for ball bearings)
- Evidence of static and dynamic load capacity of bearing raceways
- Necessary case hardening depth

## Method 2: Detailed FE calculation

With this method slewing bearings can be calculated with all necessary details. In addition to method 1, the following is considered:

- The bolt connection modelled after VDI 2230
- All contact joints
- Details of the bearing rings such as bore holes

### Results of the FE calculation in addition to method 1:

- Evidence of static and dynamic load capacity of bolt connection according to common rules
- Evidence of static and dynamic load capacity of bearing rings according to common rules
- Behaviour at contact joints (gaping, sliding)
- Deformations at the sealing gaps

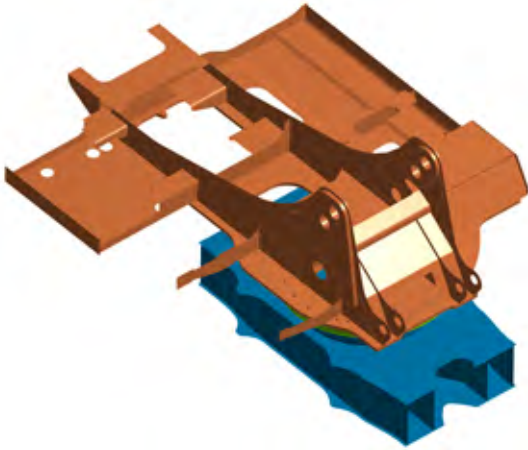

3D initial model for FE calculation

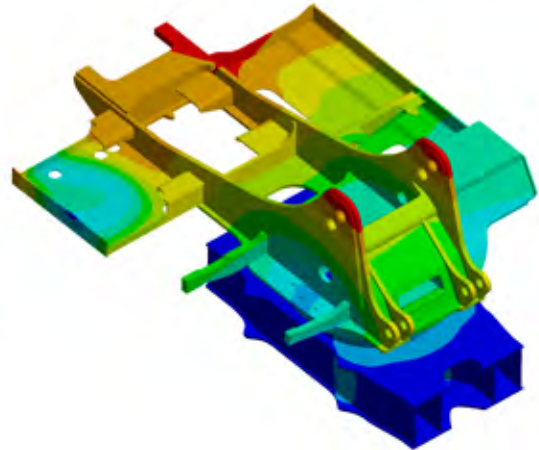

3D results chart of FE calculation

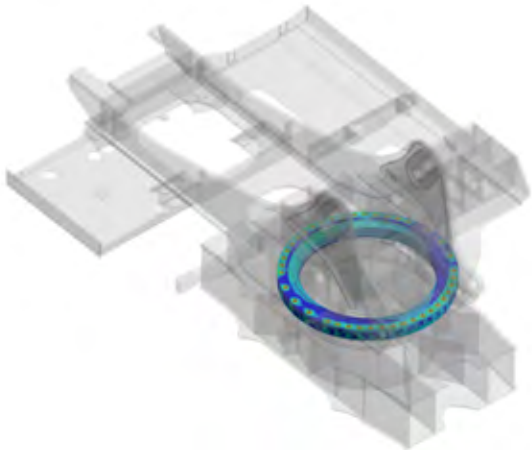

3D stress diagram for slewing bearing

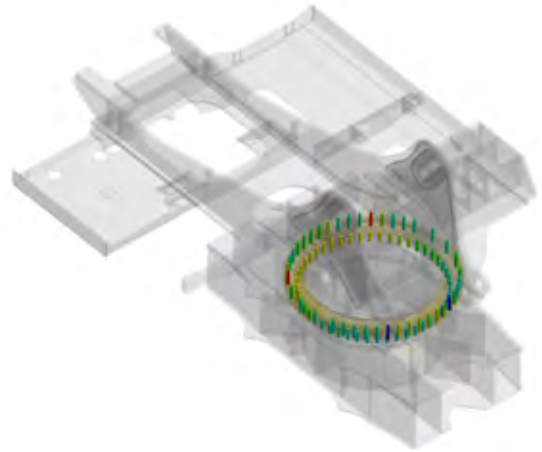

3D stress diagram for bolts

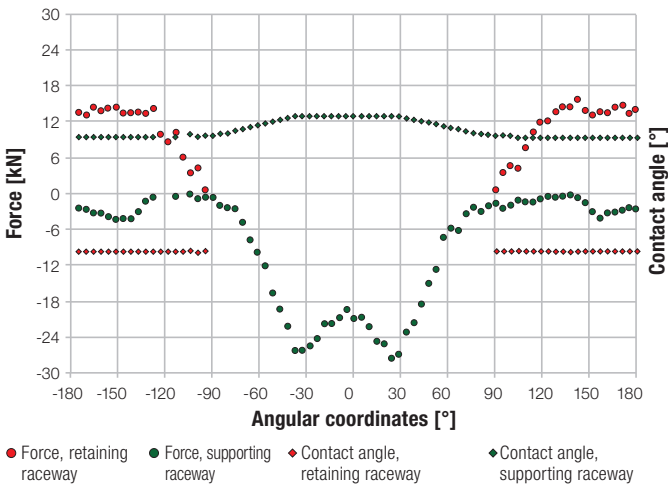

Force distribution loading condition digging (hydraulic excavator)

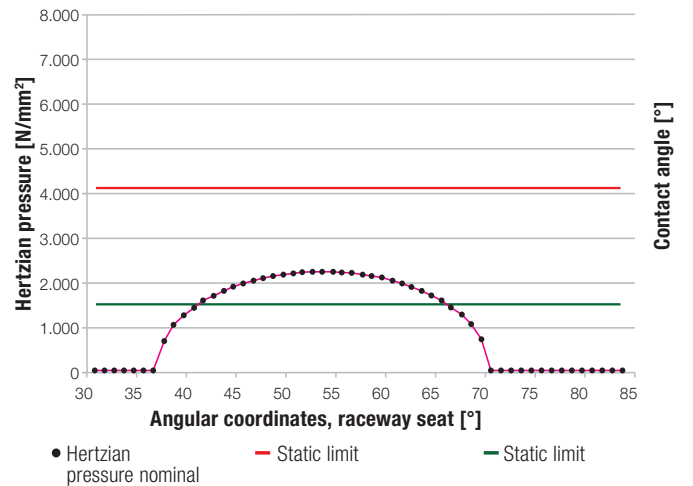

Hertzian pressure curve loading condition digging (hydraulic excavator)

# 15 Assessment of the adjacent construction by Liebherr

The service life of the bearing is reduced with increasing deviation from the specified tolerances of the adjacent construction (in chapter 12). Using a calculation model developed especially by Liebherr it is possible to determine this reduction of the service life when the tolerances cannot be observed for technical or economic reasons. These special cases must be checked by Liebherr in detail.

The unevenness of an adjacent construction leads to tensi-  
oning of the raceway and thus to a higher Hertzian pressure between the rolling element and raceway. This also has an effect on the load by external forces and torques, thus leading to preliminary wear of the bearing.

In the case of a smaller load in relation to the load rating, the influence of the unevenness is more pronounced than in the case of a larger load.

Based on the following data, Liebherr is able to make a statement about the service life reduction for four-point ball bearings and triple-row roller bearing.

Relevant data of measured adjacent construction:

- Number of shafts across the circumference
- Double amplitude of unevenness idealised as sine curve

or

- measurement plot

From the result Liebherr is able to make a statement about the reduction of the service life of the bearing as a percentage.

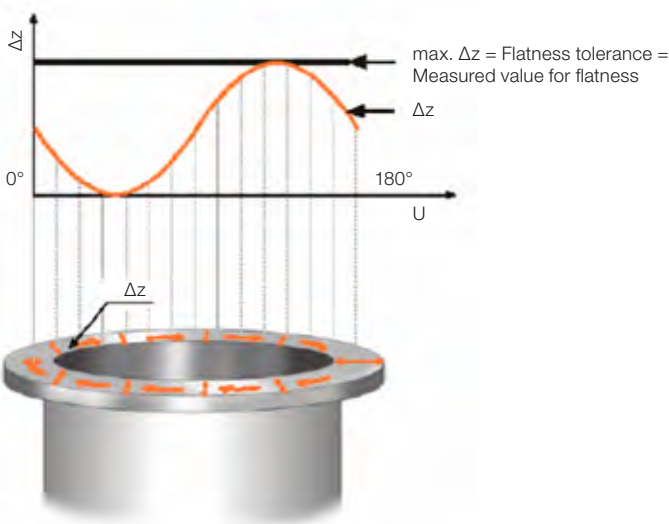

Display of double-shaft circumference imperfection

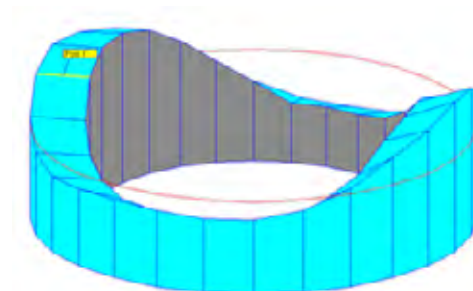
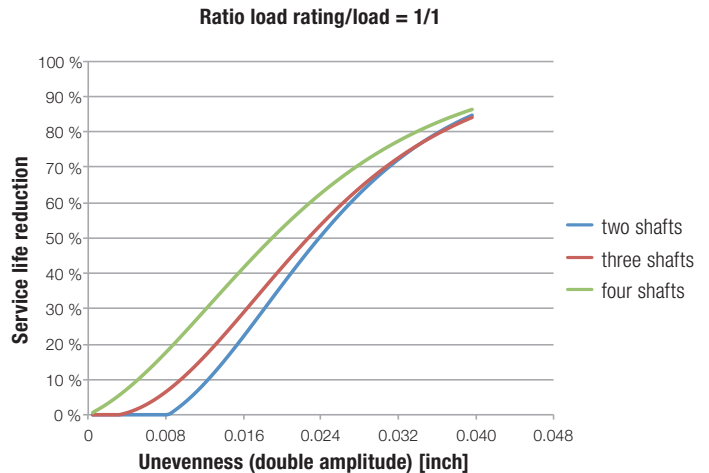

Example of measurement result of connection surface in 3D diagram

# 16 Bearing mounting

Slewing bearings are generally fastened to the adjacent construction. The following parameters must be taken into account when dimensioning the bolt connection and the assembly parameters:

## Installation position of the large diameter bearing

If the bearing is installed so that the axial load relieves the bolts, then this is called a supporting load. In contrast, if the bearing is installed so that the axial force puts an additional load on the bolts, then this is called a suspended load.

For the capacity of the Liebherr slewing bearings, according to the specified limiting load curves (see tables "Technical data"), it is assumed that there is a supporting load.

If the suspended installation position is selected, the bolt connection and the raceway design must be checked in each case by Liebherr.

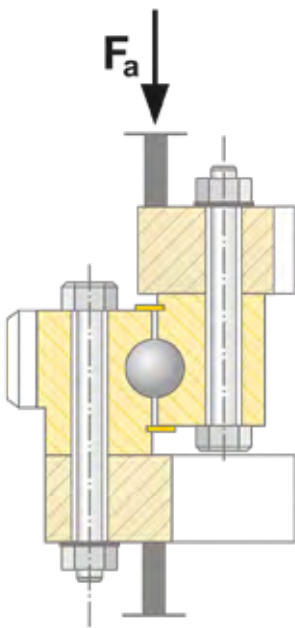

Arrangement of bearing with supporting load

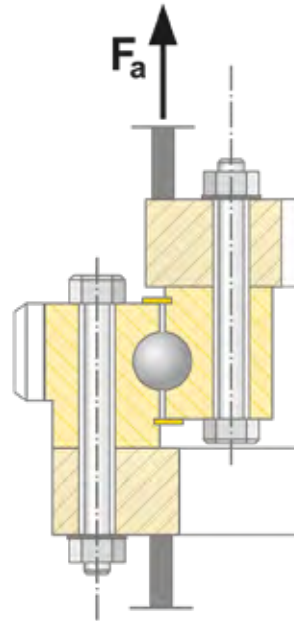

Arrangement of bearing with suspended mounting

The assembly preload force  $F_M$  must prevent the gapping of the joints and guarantee the frictional connection at the joining areas throughout the service life of the bearing. It should be noted that the preload force is reduced during operation by setting. Therefore, bolt connections must be tightened according to the installation and maintenance declarations, in order to balance the setting behaviour in the connection.

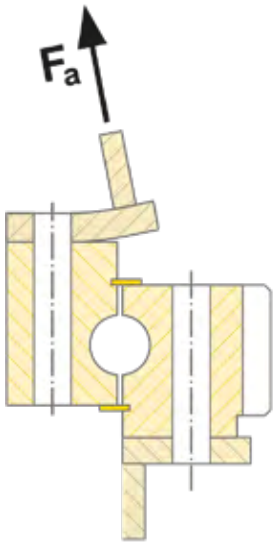

Example 1: Removal of adjacent construction from the joining area

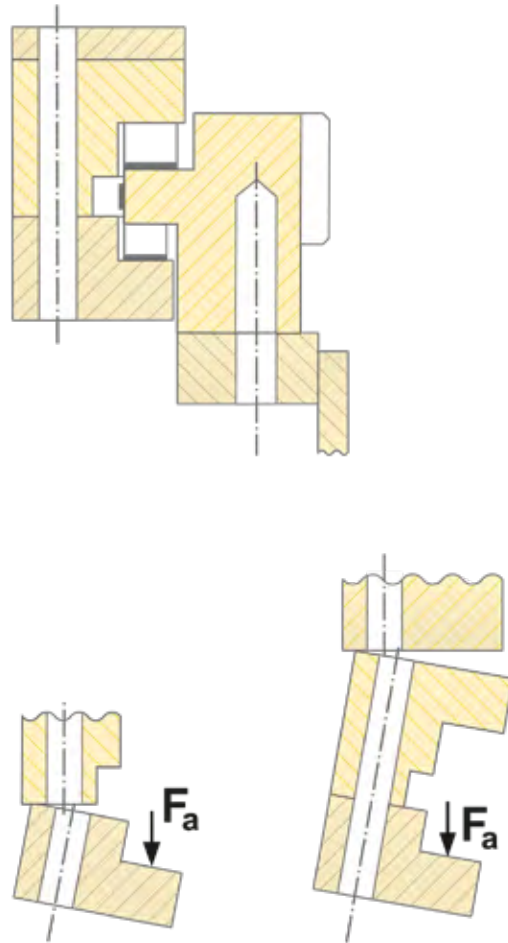

Example 2: Gaping of bearing rings i.a.w. DNV GL

## Assembly preload forces for bolts i.a.w. VDI 2230

Strength class Metric ISO thread	8.8		10.9		12.9	
	Tensioning force $F_M$ [lbf]	Maximum tightening torque $M_A$ [ft-lbf]	Tensioning force $F_M$ [lbf]	Maximum tightening torque $M_A$ [ft-lbf]	Tensioning force $F_M$ [lbf]	Maximum tightening torque $M_A$ [ft-lbf]
<b>M10</b>	6,519	39,828	9,442	58,267	11,016	68,593
<b>M12</b>	9,442	68,593	13,938	101,046	16,186	118,010
<b>M14</b>	13,039	109,159	18,884	160,789	22,256	188,078
<b>M16</b>	17,760	169,639	26,078	249,296	30,349	291,337
<b>M18</b>	22,256	242,658	31,698	345,917	37,093	404,922
<b>M20</b>	28,551	342,229	40,690	487,528	47,659	570,135
<b>M22</b>	35,520	467,614	50,582	666,756	59,350	779,603
<b>M24</b>	41,140	588,574	58,450	837,870	68,567	980,220
<b>M27</b>	53,954	867,373	76,885	1,234,679	89,924	1,444,884
<b>M30</b>	65,644	1,177,887	93,521	1,677,216	109,482	1,963,390
<b>M33</b>	81,606	1,593,871	116,226	2,270,216	136,009	2,655,961
<b>M36</b>	95,993	2,048,947	136,684	2,918,533	159,839	3,415,650
<b>M39</b>	115,102	2,653,011	163,886	3,778,530	191,762	4,420,947
<b>M42</b>	131,963	3,278,463*	187,940	4,669,505*	220,088	5,464,597*
<b>M45</b>	154,219	4,094,207*	219,863	5,831,165*	257,181	6,823,186*
<b>M48</b>	173,777	4,952,729*	247,515	7,054,781*	289,554	8,255,531*
<b>M52</b>	208,173	6,363,685*	296,523	9,063,899*	346,880	10,606,879*
<b>M56</b>	240,096	7,928,792*	342,159	11,292,812*	400,385	13,215,636*
<b>M60</b>	280,337	9,834,652*	399,261	14,007,040*	467,153	16,391,578*
<b>M64</b>	317,205	11,843,771*	451,866	16,868,781*	528,751	19,740,109*

\*for bolt sizes greater than M42, the values must be proven with a strain measurement of the bolts.

### The following applies for the table

#### "Assembly preload forces for bolts i.a.w. VDI 2230":

- Assembly preload forces  $F_M$  and tightening torques  $M_A$  for  $v= 0.9$  for shaft bolts with metric coarse thread i.a.w. DIN ISO 724, DIN 13-19.
- Head dimensions of hexagon bolts i.a.w. DIN EN ISO 4014 to DIN EN ISO 4018.
- Bolts with hexalobular head i.a.w. DIN 34800 or cylinder bolts i.a.w. DIN EN ISO 4762 and bore hole "medium" i.a.w. DIN EN 20273.
- Friction values  $\mu_G = \mu_K = 0.14$  at thread and contact surfaces.

The relevant parameters must be checked for each bolt connection. The tightening factors must be set up differently depending on the tightening process.

Tightening process i.a.w. VDI 2230	Tightening factor $\alpha_s$	Variation
<b>Torque-controlled</b> tightening with torque wrench, signal generating wrench or motorised torque wrench with dynamic torque measurement.	1.4 to 1.6	$\pm 17\%$ to $\pm 23\%$
<b>Limit-value controlled</b> tightening, motorised or manual.	1.2 to 1.4	$\pm 9\%$ to $\pm 17\%$
<b>Angle-controlled</b> tightening, motorised or manual.	1.2 to 1.4	$\pm 9\%$ to $\pm 17\%$
<b>Hydraulic</b> tightening	1.1 to 1.4	$\pm 5\%$ to $\pm 17\%$

## Tightening method

The fastening bolts can be tightened using different methods. The following descriptions of the individual methods are taken from VDI 2230.

The accuracy at which a desired preload force (minimum clamping force for pressing together fastened parts) is achieved depends on the tightening method used.

### Hydraulic tightening

With hydraulic tightening the assembly preload force  $F_M$  is generated by axial elongation by means of a clamping cylinder. As the clamping cylinder is supported at the component, springback losses can be expected from the strain. Therefore, large clamp-length ratios  $\geq 5$  are recommended:

$$\frac{l_k}{d} = 5$$

$l_k$  = Clamp length  
 $d$  = Bolt diameter

An advantage of this method is that the bolt is not affected by torsional or bending stress in comparison to other methods. The friction, which occurs for example with the torque-controlled method, is also eliminated here. As a result, the assembly preload force of the bolt can be achieved with a smaller variation.

# Precise tightening of bolt connections of Liebherr slewing bearings with the ITH Stretch method

In order to guarantee the high product quality and long service life of Liebherr slewing bearings, the bolt connections must be preloaded precisely and evenly.

Liebherr recommends using the ITH Stretch method, as with this tightening method no frictional, bending or torsional loads occur in the bolt connection (hydraulic friction- and torsion-free tightening). The assembly preload force  $F_{VM}$  required is introduced axially to the bolt connection. This achieves the highest possible level of uniformity and precision.

## Operating principle

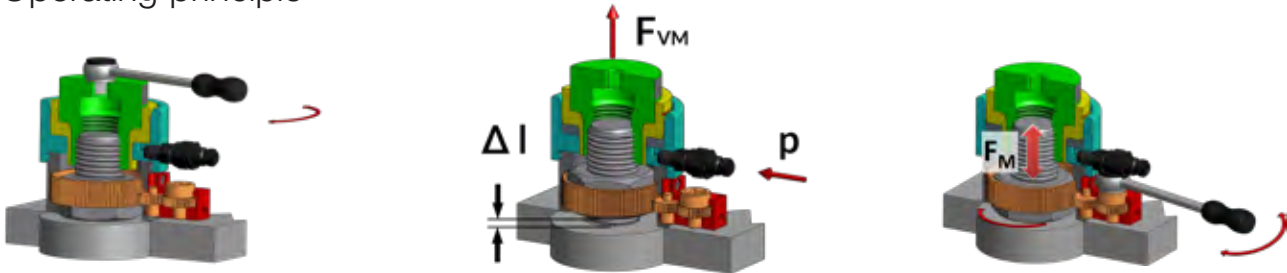

### 1. Screwing

The interchangeable bush with internal thread of the ITH bolt tensioning cylinder is fastened onto the projecting thread.

### 2. Preloading

By applying a defined hydraulic pressure  $p$  the stud-bolt is extended axially ( $\Delta l$ ). The assembly preload force  $F_{VM}$  is introduced to the bolt connection without any frictional, torsional and bending moments.

### 3. Nut

After the hydraulic pressure is reached the nut is arranged near the contact surface using a torque wrench. Then the pressure is released.

## Advantages of the ITH Stretch method

- No friction between contact surface and nut, as well as internal thread and bolt thread.
- No bending and torsional loads in stud bolts, pure tensile load.
- High precision and repeat accuracy of target value of assembly preload force  $F_M$  as friction-free.
- Small  $\alpha A$  values of up to 1.05\* can be realised with the design of bolt connections.
- Large preload forces with small tool dimensions.
- Optimal for construction site installations thanks to compact assembly tools for bolts and nuts with small dimensions.
- Parallel and precise preloading of several bolts possible (ITH Multi Tensioning).  
Ideal for large diameter bearing applications.
- Technology leader ITH Schraubtechnik, market leader in preloading of bolts for large diameter bearings, over 35 years of experience, over 200 international patents.

\* for clamp length ratio  $l_K/d \geq 5$  and mechanically machined connecting elements. ITH recommends ITH round nuts RMS/RMZ.



### Bolt tensioning cylinder for Liebherr slewing bearings Type MSK, bolt quality 10.9

- Increased working speed – Flexible rotary sleeve, automated piston return and direct pinion accelerate the bolt fastening process.
- Precision – Preloading with no friction, torsion and bending moment, linear relationship between control parameter p and target parameter FM, as well as parallel preloading of several bolts possible at the same time (ITH Multi Tensioning), guarantee a precise result.
- Safety concept – Patented cycle counter, patented breaking load device and patented protective cover at handle piece increase occupational safety.
- Additional equipment – NIOX surface coating, ergonomic carrying device and handle piece round off innovative overall concept – leading in large diameter bearings.

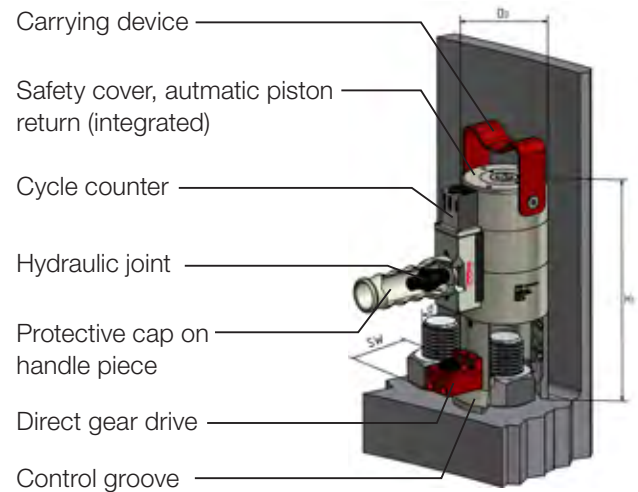

### Sizes of type MSK

Type	Order no.	Preload force		Nominal diameter Ø d		Bolt Width across flats SW		Outer diameter-Ø D <sub>3</sub>		Total height H <sub>1</sub>	
		[kN]	[lbs]	[mm]	[in]*	[mm]	[in]*	[mm]	[in]*	[mm]	[in]*
<b>MSK 24 - 10.9</b>	33,52791	308.5	69354	M 24x3	7/8	36	1 4/9	57.0	2.24	188.7	7.50
<b>MSK 27 - 10.9</b>	33,52792	401.5	90261	M 27x3	1	41	1 5/8	63.5	2.50	197.4	7.86
<b>MSK 30 - 10.9</b>	33,52793	485.5	109152	M 30x3.5	1 1/8	46	1 4/5	70.0	2.76	199.2	7.98
<b>MSK 33 - 10.9</b>	33,52794	606.3	136302	M 33x3.5	1 1/4	50	2	78.3	3.08	222.6	8.84
<b>MSK 36 - 10.9</b>	33,52795	708.3	159233	M 36x4	1 3/8	55	2 1/5	82.6	3.25	235.0	9.33
<b>MSK 39 - 10.9</b>	33,52796	842.2	189335	M 39x4	1 1/2	60	2 3/8	90.8	3.57	255.8	10.21
<b>MSK 42 - 10.9</b>	33,52797	974.4	219044	M 42x4.5	1 5/8	65	2 4/7	98.0	3.86	257.0	10.35
<b>MSK 45 - 10.9</b>	33,52798	1140.5	256396	M 45x4.5	1 3/4	70	2 3/4	105.0	4.13	274.0	10.98
<b>MSK 48 - 10.9</b>	33,52799	1288.4	289645	M 48x5	1 7/8	75	3	111.5	4.39	287.0	11.57
<b>MSK 52 - 10.9</b>	33,52800	1529.7	343899	M 52x5	2	80	3 1/8	122.0	4.80	301.2	12.09
<b>MSK 56 - 10.9</b>	33,52801	1785.0	401286	M 56x5.5	2 1/4	85	3 1/2	130.5	5.14	329.0	13.80
<b>MSK 60 - 10.9</b>	33,52802	2125.8	477892	M 60x5.5	2 3/8	90	3 3/4	140.8	5.54	336.0	13.46
<b>MSK 64 - 10.9</b>	33,52803	2336.8	525336	M 64x6	2 1/2	95	3 7/8	147.8	5.82	344.5	13.87
<b>MSK 68 - 10.9</b>	33,52804	2745.0	617103	M 68x6	2 3/4	100	4 1/4	159.8	6.29	375.8	14.86
<b>MSK 72 - 10.9</b>	33,52805	3041.2	683697	M 72x6	3	105	4 5/8	168.0	6.61	385.0	15.24
<b>MSK 80 - 10.9</b>	33,52806	3814.1	856746	M 80x6	3 1/4	115	5	182.0	7.16	439.0	17.28
<b>MSK 90 - 10.9</b>	33,52807	489.0	1045361	M 90x6	3 1/2	130	5 3/8	211.0	8.30	485.0	19.09
<b>MSK 100 - 10.9</b>	33,52808	6134.1	13790000	M 100x6	4	145	6 1/8	230.0	9.05	510.4	20.08

Other bolt/nut configurations can be purchased on request. \*Increase in bolt thread for inch thread: 8 UN.

Liebherr recommends multilevel bolt tensioning cylinders of type MSK from the manufacturer ITH Schraubtechnik from Meschede, Germany. Single-level bolt tensioning cylinders can be purchased on request. The values indicated are designed for hexagon nuts i.a.w. DIN 4032.

## Torque-controlled tightening

Torque-controlled tightening is effected by indicating or signal generating torque wrenches or torque screwdrivers. In addition to the torque, the angle of rotation from a certain torque value is generally also measured in order to monitor the procedure. This procedure is widely used due to the affordable equipment and simple handling.

The setting of the tightening devices should only be determined at the original part during trial turning. This is possible using three measured variables: breakaway torque, prevail torque or elongation measurement of the bolt. The preferred measurement of the elongation of the bolt should be done by ultrasound or mechanically. The preload force reached is calculated from the proportionate bolt flexibility.

For high-stress bolt connections tightening with impact screwdrivers is not recommended, as the tightening factors are very high in the elastic range. Special impulse wrenches with hydraulic cell offer smaller tightening factors, designed for the respective bolt connection.

## Limit value controlled tightening

With limit value controlled tightening procedures, the bolt is tightened irrespective of the friction in the layer until the overall stress (torsional and tensile stress) roughly corresponds to the yield strength of the bolt. The bolt must be preloaded with a snug torque beforehand.

The calculation of the onset of yielding of the bolt is effected by measuring the torque and angle of rotation. The difference quotient of the two variables is synonymous with the increase of tangent, which is formed in the torque-angle of rotation curve. As soon as the bolt material is in the plastic deformation range, the difference quotient falls and triggers the shutdown signal.

An advantage vis-a-vis other tightening procedures is that a special design of the bolt for the largest possible assembly preload force is not required. With an increase of the assembly preload force due to less thread friction, the torsion content is also reduced accordingly.

## Angle-controlled tightening

The angle-controlled tightening procedure is based on the (theoretically) proportional connection between the angle of rotation and length variation of the bolt above the pitch of the thread.

First of all, when tightening with a snug torque the bolt is preloaded so that there is complete contact with the joint faces. This is required, as for the measurement of the angle of rotation both the pressure deformations within the clamped parts and the elastic and plastic deformations occurring in the joint faces up to the complete surface contact are also measured. In addition to the angle of rotation, the torque is also nearly always measured in order to monitor the process.

Experience has shown that the procedure only achieves its maximum precision in the super-elastic range, as angle errors are unlikely to have much of an effect.

The angle of rotation should be determined in tests on original components, in order to properly calculate the real flexibility of a structure.

As with this procedure the yield strength of the bolt is exceeded, the reusability of the bolts is no longer possible.

## Arrangement of bolts

The bolts are normally distributed evenly over the pitch circle circumference. However, upon request bearings can also be realised with an uneven bolt distribution. The bolts are ideally tightened crosswise according to the diagram below.

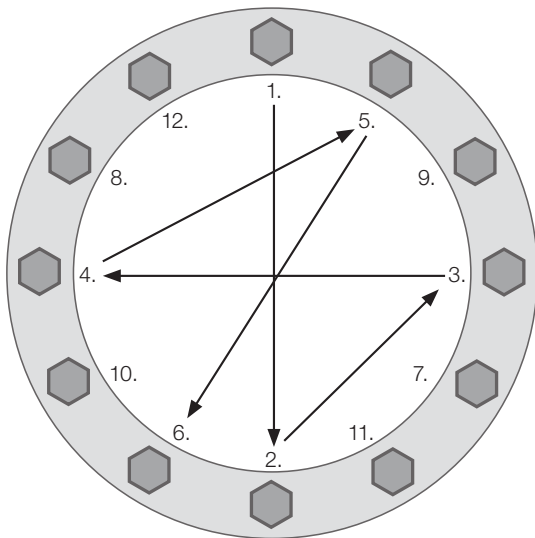

Tightening of the bolt connection crosswise

## Strength categories of bolts

The strength category of the bolts used is defined by default as 10.9. However, for special requirements bolts from other categories may also be used. The bolts which can be used are listed in the table "Mechanical properties of bolts". In a particular case, the deviation from the standard bolt must be clarified with Liebherr.

### Mechanical properties of bolts i.a.w. EN ISO 898-1

Strength values	Strength category 8.8		Strength category 10.9	Strength category 12.9
	D ≤ M16	D > M16		
Tensile strength $R_m$	min. 116 ksi	min. 12.4 ksi	min. 150.8 ksi	min. 176.9 ksi
0.2% yield strength $R_{p0.2}$	min. 95.7 ksi	min. 95.7 ksi	min. 136.3 ksi	min. 159.5 ksi

## Minimum bolt depth

The minimum bolt depth of threads for tolerance class "mid" after calculation of VDI 2230 amounts:

### Minimum bolt depth of threads

Material adjacent construction/ Nut	Strength categories of bolts		8.8	8.8	10.9	10.9	12.9	12.9
	Thread fineness d/P		<9	≥9	<9	≥9	<9	≥9
S235			1.0 × d	1.25 × d				
S355, C45N			0.9 × d	1.0 × d		1.2 × d		1.4 × d
42CrMo4+QT, C45V			0.8 × d	0.9 × d		1.0 × d		1.1 × d

d = Thread Outer-Ø [mm]

Bolts with metric ISO-thread (regular thread)

P = Gradient of thread [mm]

up to M 30: d/P < 9

> M 30: d/P > 9

## Clamping length

Liebherr recommends the insertion of a clamping length  $l_k \geq 5 \times d$  (d describes bolt diameter) for minimizing the loss of pretension force.

## Surface stress at the contact areas

The boundary surface stress of the contact areas must be observed. The assembly surface stress is roughly calculated as follows:

$$\sigma = \frac{1.1 \times F_M}{A_p}$$

$F_M$  = Assembly preload force  
 $A_p$  = Bolt head or nut contact area

The contact area  $A_p$  is dependent on the type of bolt selected. The following values for the surface stress cannot be exceeded i.a.w. VDI 2230 (guide values):

### Boundary surface pressures for bolt head contacts\*

Material of contact surface	Boundary surface stress
S235	71 ksi
S355	110.2 ksi
42CrMo4+QT	155.2 ksi (based on $R_m$ , LN 180)
Cq45	111.7 ksi
GJS 400	87 ksi

\*Guide values i.a.w. VDI 2230

If the boundary surface stress is exceeded, then larger head contact diameters may be used with corresponding washers, for example, i.a.w. DIN EN 14399-6.

## Frictional connection

The connection points must be carefully cleaned of paint, contamination, welding beads and grease. The bearing rings must lay flat on all sides. In special cases suitable adhesives may be required to improve the frictional connection. As an alternative to adhesives, the contact area may also have a zinc spray coating, whereby the friction coefficient of the area is also increased.

A mechanical option to transfer radial forces to the bearing is the fitting of the bearing in a radial centring.

The design of the bearings with these radial centrings is generally possible, however it must be agreed with Liebherr in each case.

# 17 Production

## Production process



1 Turning and drilling



2 Gear milling



3 Induction hardening



4 Final assembly

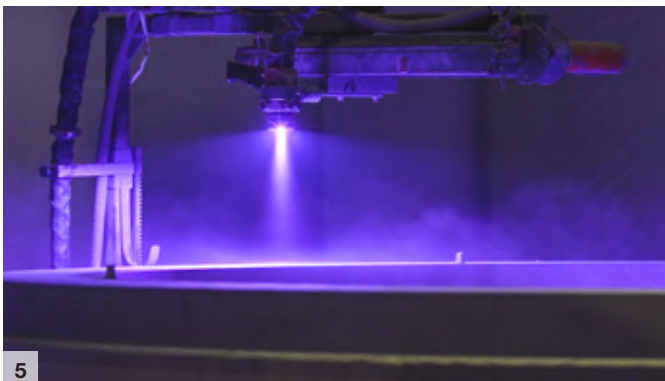

5 Surface treatment



6 Completed large diameter bearing

## Measurement/Quality control



1  
Magnetic particle inspection



2  
Hardness measurement



3  
Measurement of hardness depth



4  
Surface inspection (surface roughness)



5  
Dimension checks and visual inspection

## Induction hardening – A core competency of Liebherr

Liebherr provides various induction hardening machines in production. With individual machine configuration options, both hardness depths greater than 0.3937 inch and hardness depths with minimum warpage can be realised.

The swivel-mounted machine benches can be positioned variably up to an inclination of 70°. This way optimal cooling behaviour of the workpiece of any contour is guaranteed.

The sensor-controlled position, together with a continuous temperature measurement, which is used both for the tooth flank hardening and the raceway hardening, ensures a consistently high quality and repeat accuracy.

The tool required for hardening, the inductor, is manufactured in-house at Liebherr, from the development to the design through to the manufacture.

This know-how guarantees quick and efficient realisation of solutions for new tasks and challenges.

The highest level of quality of the components is guaranteed using various test procedures, such as ultrasonic and magnetic particle inspection, which are carried out directly after the hardening of the finished workpieces. Regular checks of hardness samples in a separate metallurgical laboratory guarantee compliance with the required hardness parameters according to customer specifications, as well as our own quality standards.

Using two tempering furnaces, workpieces can be stress relieved or annealed at a temperature of up to 1202°F.

Furthermore, Liebherr works very closely with well-known machine manufacturers in the area of induction hardening and therefore always uses the latest technology



Induction hardening at Liebherr

# 18 Lubrication

## Lubrication of bearing raceways

Appropriate lubrication is the basic requirement for proper functioning and a long service life of the bearing raceways. In principle, the lubricant must fulfil the following tasks:

- Formation of a sufficiently firm film of lubricant at the contact areas through the use of lubricants with special additives.
- Reduction of the friction between rolling elements and raceways, as well as rolling elements and spacers.
- Sealing of the raceway system on the outside against dirt and moisture ingress and thus build-up of corrosion protection for the raceway system.

A bearing can generally be lubricated with oil or grease. Normally the lubrication of the bearing raceways is effected by grease supply via lubrication ports with nipples.

In Liebherr slewing bearings, only high-quality lubricants should be used which are suitable for the respective application. These must basically have the following characteristics:

- Sufficient temperature range of application
- Sufficient lubricating ability of the base oil
- Sufficient anti-corrosion properties i.a.w. DIN 51802
- Low tendency to absorb water i.a.w. DIN 51807
- Sufficient adherence
- Good ageing resistance

## Initial lubrication

Liebherr slewing bearings are filled with Liebherr grease at the factory before delivery. The grease is a lithium soap grease of class KP2K-30 i.a.w. DIN 51825. The grease also has additives for corrosion protection.

The fill level of the bearing by means of the initial filling is based on the requirements of the respective application and is defined by Liebherr on a case by case basis.



## Relubrication of bearing raceways

The bearing raceways of the large diameter bearings must be regreased at defined regular intervals. The intervals can be found in the maintenance schedule.

The relubrication intervals generally depend on the operating conditions, the prevailing environmental factors, as well as the type of bearing or the chosen type of sealing system. The following intervals may be used as a guide for the scheduled relubrication:

## Guide values for relubrication periods

Operating conditions	Guide value for relubrication period
light	every 250 operating hours
normal	every 200 operating hours
extreme	every 100 operating hours

The values indicated in the table only serve as a guide.

### Guide values for relubrication periods

In the case of operation in particularly climatic conditions (for example in the tropics) or where there is a particularly high accumulation of dust and dirt (for example in the mining area), as well as continuous rotation of the bearing, the lubrication cycles are shortened accordingly.

## Unscheduled relubrication

In addition to the scheduled lubrication intervals explained in chapter 18, unscheduled relubrication must generally be effected in each of the following cases:

- Before and after extended breaks in operation (generally three months) or downtimes (for example crane or construction machines). Agree with Liebherr in the case of a specific application.
- Where there are high moisture levels, for example from spray or splashed water.

## Relubrication process

The aim of relubrication is to fully replace the grease which has aged by the operation of the large diameter bearing with new grease. If there is no specific lubrication instruction, the raceways must be lubricated as follows: Via the lubricating nipple the large diameter bearing is filled with fresh grease by slowly turning the bearing until the grease is evenly distributed around the circumference and grease emerges under the sealing lips and forms a built-up grease collar.

For special applications, such as in material handling equipment or wind turbines, relubrication instructions tailored to the respective application must be applied.

## Lubricant quantities

The required lubricant quantities for the initial lubrication and the relubrication are defined by Liebherr for each large diameter bearing based on the requirements.



Built-up grease collar at the bearing seal

# Lubrication of gearing

The lubricants used in the bearing raceways of the Liebherr slewing bearings are also suitable for the lubrication of the gearing. The same or an adequate lubricant should be used for compatibility purposes (see Table "Lubricants for slewing bearings").

The appropriate lubricant must be used according to the vehicle power level.



Lubricated gearing in operation

## Initial lubrication before commissioning

The gearings of the Liebherr slewing bearings are protected against corrosion (anti-corrosion oil or paint) at the factory before delivery and must be lubricated intensively before the initial commissioning.

For the initial lubrication, greases with EP additives (Extreme Pressure) for open gearings are recommended. The vehicle power level of the lubricant i.a.w. ISO 14635-1 should also be at least 12. The Liebherr grease for gearing is generally recommended (see table "Lubricants for slewing bearings").

## Relubrication of gearing

The relubrication periods for the gearing of the bearings depend to a large extent on the operating conditions and environmental factors in the application.

### Relubrication intervals for gearing

Type of application/Frequency of use	Relubrication interval
Seldom and only rotated with light to medium loads	weekly to monthly
Intensive rotations under high load and frequent impacts	daily
Intensive rotations high load and frequent impacts during multi-shift operation	several times a day

## Relubrication process and quantities

Grease must be coated or sprayed on the tooth flanks of the gearing. The application of the grease should be effected in thin and even layers. The contact areas at the tooth flanks of the gearing must always have a lubricating film.

Excessive lubricant quantities do not offer any benefits. Excessive grease should be removed again using a suitable tool or equipment.

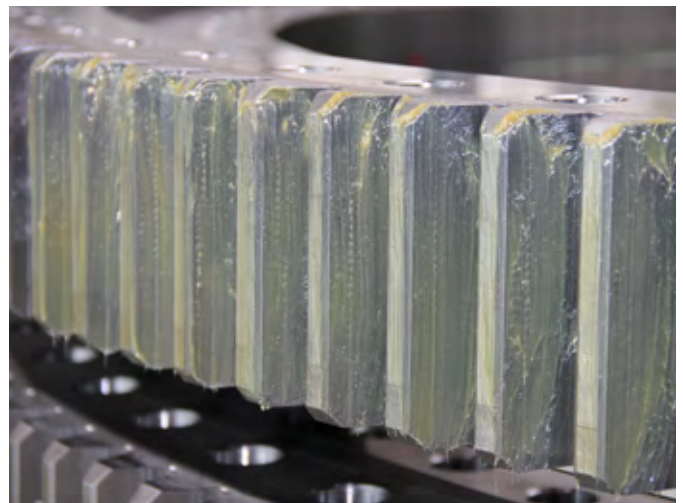

Initial lubrication of gearing

# Lubricants

In general, Liebherr recommends Liebherr lubricants for slewing bearings. If it is not possible to purchase Liebherr lubricants, the lubricants listed in the table "Lubricants for slewing bearings" may be used as an alternative. The suitability and use of non-Liebherr lubricants is based on the recommendation from the respective manufacturer.

For the automatic lubricant supply to the gearing, the use of lubricant dispensers or lubrication systems in conjunction with central lubrication systems is also possible.

## Lubricants for slewing bearings

Manufacturer	Rolling contact (KPF 2 N-25 or KPFHC 1 N-60)	Gearing contact (OGPF 2 S-30)
Liebherr	<b>Universal Grease 9900</b> 248 K to 423 K (-13°F to 302 °F)	<b>Universal Grease 9900</b>
	<b>Universal Grease Arctic</b> 213 K to 413 K (-76°F to 284°F)	
Castrol	Molub-Alloy 860/220-2 ES 253 K to 413 K (-4 °F to 284°F)	Molub-Alloy OG 936 SF Heavy 263 K to 353 K (14°F to 176°F)
	Molub Alloy 777-2 NG) 253 K to 393 K (-4°F to 248°F)	Molub-Alloy 9790/2500-1 253 K to 363 K (-4°F to 194°F)
Fuchs	Renolit FLM 2 243 K to 413 K (-22°F to 284°F)	Renolit CX-HT 2 253 K to 473 K (-4°F to 392°F)
	Renolit FLM 302 253 K to 393 K (-4°F to 248°F)	
	Renolit Polar Black 223 K to 393 K (-58°F to 284°F)	
Lubritech	Lagermeister EP-2 253 K to 403 K (-4°F to 266°F)	Ceplattyn KG 10 HMF 263 K to 413 K (14°F to 284°F)
Total	COPAL OGL 2 258 K to 423 K (5°F to 302°F)	CERAN GEP 253 K to 453 K (-4°F to 356°F)
Agip/eni	Agip GR SM 238 K to 403 K (-31°F to 266°F)	

Liebherr Universal Grease 9900 is suitable both for the raceway and the gearing.

# 19 Packaging, transportation and storage

## Packaging and storage

Liebherr slewing bearings require careful handling during transportation and storage.

Liebherr slewing bearings are packaged at the factory on a standard transport pallet. The dimensions of the pallet, additional protective measures, as well as the necessary preservation, depend on the technical specifications of the product. This is checked together with the customer before the first shipment of a product in order to submit a packaging proposal.

Liebherr pursues the principle of the simplest packaging which is safe for transport. The packaging is manufactured by trained and qualified personnel, complies with current standards (e.g. phytosanitary measures) and is optimised in terms of minimal waste disposal.

Returnable packaging is also offered in order to return special packaging and guarantee consistently high packaging quality, as well as cost efficiency.

The large diameter bearings are treated with anti-corrosion agents as standard. This preservation allows the slewing bearings to be stored for up to six weeks in sheltered and tempered areas.

With special packaging this preservation may be extended to 18 months if necessary. Longer storage periods must be assessed by Liebherr.

In addition to the packaging and preservation for the transportation to the intended location, special pallets, special markings or handling equipment are also possible upon request in order to simplify logistics at the customer's premises.

For shipping to third countries, special markings and optional additional packaging (e.g. hatches) may be attached for customs inspection, which prevent damage to the anti-corrosion agent and guarantee a safe transport chain. Liebherr may make corresponding solution proposals depending on the product and intended location purpose.

## Transport

Due to their dimensions and weights, large diameter bearings often place high requirements on the transportation company. If horizontal transportation of the product is difficult for logistical and/or road transport circumstances, Liebherr offers alternatives suitable for everyday use.

These include diagonal or vertical loading with the aid of skids, as well as special equipment made from wood, plastic or metal, which ensure smooth transportation.

Liebherr offers Free House Delivery as an option, which is based on years of experience and special conditions with select freight carriers.

Slewing bearings must always be moved during crane transportation using suitable hoists and lifting gears, which must be secured to the intended transport lifting holes with suitable lifting eyes. The number and arrangement of the lifting eyes are defined during the project planning stage.



Low-loader with diagonal mounting

## 20 Control/Inspection

Large diameter bearings must be serviced in specific cycles. This includes, for example, the relubrication, checking seals, tilting clearance measurement and also reduction measurement.

These measures serve to avoid possible wear of the bearings or detect wear at an early stage. This in turn prevents unnecessary repair costs and production downtimes. This is why we recommend regular bearing inspections and wear measurements.

Wear of the bearing raceway is generally noticeable by a reduction or change in the axial movement. Depending on the application, the wear development can be determined from a reduction or tilting clearance measurement.

Wear at the gearing depends to a large extent on the application.

### Reduction measurement

If the load of the bearing is mainly in an axial direction (load centre within the raceway diameter of the bearing), it is recommended to perform a reduction measurement.

The reduction measurement is also effected between the lower adjacent construction and the bearing ring fastened to the upper adjacent construction.

For the reduction measurement the values from the tables in chapter 20 for the permissible bearing clearance increases apply.

### Tilting clearance measurement

In the case of bearings mainly loaded with tilting moments (e.g. cranes), it is recommended to measure the tilting clearance at the bearing.

The tilting clearance measurement is effected between the lower adjacent construction and the bearing ring fastened to the upper adjacent construction. The measuring point should be as close as possible to the raceway system, in order to keep the effect of deformations low.

#### Procedure for tilting clearance measurement:

- 1) Define position for the measurement during commissioning.
- 2) Perform reference measurement during commissioning.
- 3) Mark measuring points around the circumference (or measuring point every 90°).
- 4) Use dial gauges with a precision of at least 0.00039 inch.
- 5) Apply maximum restoring moment in order to set the dial gauges to zero.
- 6) Generate forward tilting moment through load capacity.
- 7) Swivel the upper structure and repeat the measurements at the marked positions.

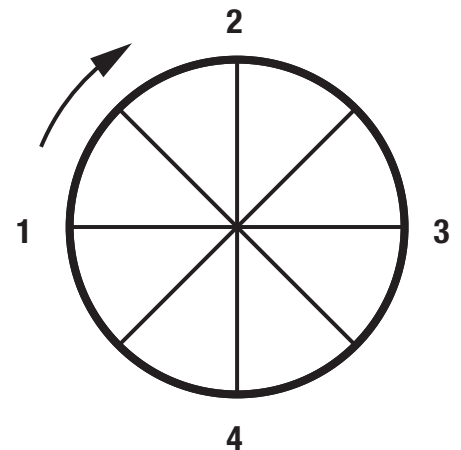

**Procedure for reduction measurement:**

- 1) Determine reference points similar to the tilting clearance measurement.
- 2) Mark measuring points from a defined position on the lower structure (or every 90°).
- 3) Perform control measurements at each of the marked measuring points at defined intervals.

Through regular reduction or tilting clearance measurements, progressive wear in the bearing can be detected early and affected components can be replaced.

## Limit values for bearing clearances

For the tilting clearance measurement the production-related bearing clearances (see chapter 9 "Bearing clearance") are added. The specified permissible bearing clearance increases only apply for bearings with clearance.

### Maximum permissible bearing clearance increases – single-row and double-row four-point ball bearings

Raceway diameter [inch] to	Ball diameter [inch]										
	20	22	25	30	35	40	45	50	55	60	70
39.37	0.0591	0.0591	0.0591	0.0630	0.0709	0.0787	0.0866	0.1024	0.1024		
49.21	0.0591	0.0630	0.0630	0.0669	0.0709	0.0827	0.0906	0.1063	0.1063	0.1102	
59.06	0.0630	0.0669	0.0669	0.0709	0.0709	0.0827	0.0945	0.1063	0.1102	0.1142	0.1181
68.90			0.0709	0.0709	0.0748	0.0866	0.0945	0.1102	0.1142	0.1181	0.1220
78.74			0.0709	0.0748	0.0787	0.0906	0.0984	0.1142	0.1142	0.1181	0.1260
88.58			0.0748	0.0787	0.0827	0.0945	0.1024	0.1181	0.1181	0.1220	0.1299
98.43			0.0748	0.0787	0.0827	0.0945	0.1063	0.1181	0.1220	0.1260	0.1299
108.27			0.0787	0.0827	0.0866	0.0984	0.1063	0.1220	0.1260	0.1299	0.1339
118.11					0.0906	0.1024	0.1063	0.1260		0.1299	0.1378
127.95					0.0945	0.1063	0.1142	0.1299		0.1339	0.1417
137.80						0.1102	0.1181	0.1299		0.1378	0.1417
147.64						0.1142	0.1220	0.1339		0.1417	0.1457
157.48						0.1181		0.1339		0.1457	0.1496
177.17								0.1417		0.1535	0.1575
196.85								0.1496		0.1614	0.1654
216.54								0.1575		0.1693	0.1732
236.22								0.1654		0.1811	0.1850
255.91										0.1850	0.1890
275.59										0.1929	0.1969
295.28											0.2008
314.96											0.2126
>314.96											on request

## Maximum permissible bearing clearance increases – triple-row roller bearing

Raceway diameter (retaining raceway) [inch]	Roller diameter [inch]										
	0.6299	0.8268	0.9449	1.0236	1.2598	1.4173	1.5748	1.9685	2.3622	2.7559	3.1496
to											
15.75	0.0079	0.0087	0.0091	0.0094							
19.69	0.0083	0.0091	0.0094	0.0098	0.0110						
24.80	0.0102	0.0110	0.0114	0.0118	0.0134	0.0146	0.0154				
31.50	0.0102	0.0110	0.0114	0.0118	0.0134	0.0146	0.0154				
39.37	0.0122	0.0130	0.0134	0.0138	0.0154	0.0165	0.0173				
49.21	0.0161	0.0169	0.0173	0.0177	0.0193	0.0205	0.0213	0.0240			
59.06	0.0201	0.0209	0.0213	0.0217	0.0232	0.0244	0.0252	0.0280			
78.74	0.0236	0.0248	0.0252	0.0256	0.0272	0.0283	0.0291	0.0319	0.0358		
98.43	0.0260	0.0276	0.0283	0.0291	0.0311	0.0323	0.0331	0.0358	0.0398	0.0437	0.0476
124.02	0.0299	0.0315		0.0331	0.0350	0.0362	0.0370	0.0398	0.0437	0.0476	0.0516
157.48				0.0370	0.0390	0.0402	0.0409	0.0437	0.0476	0.0516	0.0555
196.85					0.0429		0.0445	0.0476	0.0516		
236.22					0.0469		0.0488	0.0516	0.0555		
275.59								0.0555	0.0591		
314.96									0.0634		
>314.96							on request				



## Maximum permissible bearing clearance increases – double-row ball bearing

Raceway diameter [inch]	Ball diameter [inch]												
	0.7087	0.7874	0.8661	0.9843	1.1811	1.3780	1.5748	1.7717	1.9685	2.3622	2.7559		
39.37	0.0748	0.0748	0.0787	0.0787	0.0827	0.0866	0.1024	0.1142					
49.21	0.0787	0.0787	0.0827	0.0827	0.0866	0.0906	0.1063	0.1181	0.1378	0.1457			
59.06		0.0787	0.0866	0.0866	0.0906	0.0945	0.1063	0.1181	0.1378	0.1457			
68.90			0.0906	0.0906	0.0945	0.0984	0.1142	0.1220	0.1417	0.1496	0.1614		
78.74				0.0945	0.0984	0.1024	0.1181	0.1299	0.1496	0.1535	0.1654		
88.58					0.1024	0.1063	0.1220	0.1339	0.1535	0.1575	0.1693		
98.43						0.1102	0.1260	0.1378	0.1575	0.1654	0.1732		
108.27						0.1142	0.1299	0.1417	0.1614	0.1693	0.1772		
118.11								0.1339	0.1457	0.1654	0.1732	0.1811	
127.95								0.1378	0.1496	0.1693	0.1772	0.1850	
137.80								0.1417	0.1535	0.1732	0.1811	0.1890	
147.64								0.1417	0.1535	0.1772	0.1850	0.1929	
157.48									0.1614	0.1811	0.1890	0.2008	
177.17										0.1969	0.2047	0.2165	
216.54										0.2047	0.2126	0.2205	
236.22										0.2126	0.2205	0.2283	
255.91											0.2283	0.2362	
275.59											0.2362	0.2441	
295.28												0.2520	
314.96												0.2598	
>314.96													on request

Further information and explanations can be found in the instruction manual.

# 21 Bearing selection

In general, the final and binding bearing selection is made by Liebherr, after the factors of the respective loading condition have been clarified.

The static load-bearing capacity must be checked in each case. For slewing bearings with frequent rotations, this evidence suffices. In all other cases, the dynamic load bearing capacity must also be checked.

The extreme load on the bearing is calculated from the combination of tilting moment, axial force and radial force on the bearing taking into account application-specific impact factors and safety factors. These must be set by the user if necessary or taken from the product pages.

## Bearing loads

### Load distribution in bearing

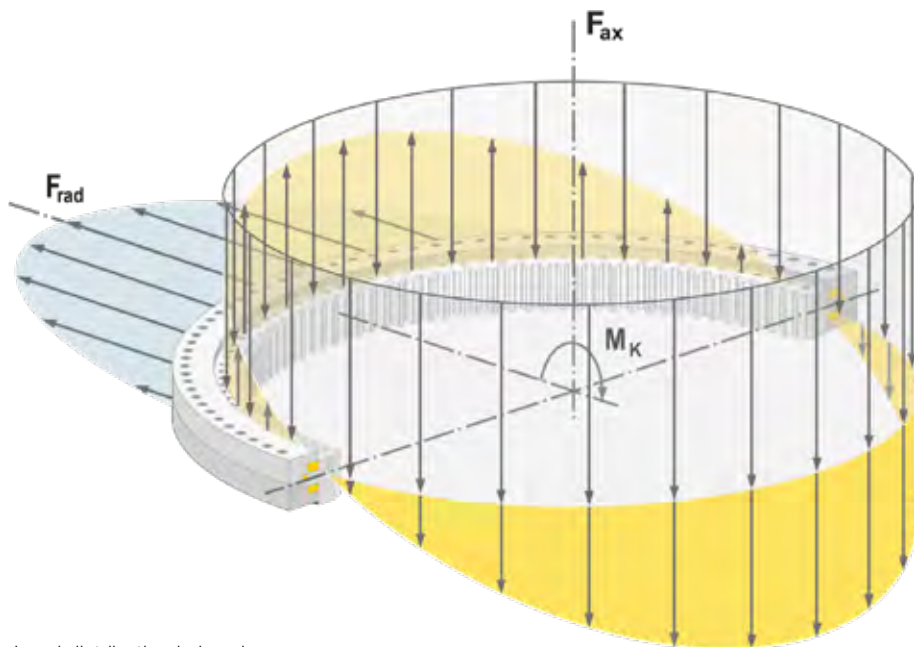

Load distribution in bearing

## Axial force $F_a$

The direction of the axial force runs parallel to the rotary axis of the bearing. In the raceway system the axial force highlights a symmetrical pressure-force distribution to the rolling elements and the raceway. The size of the rolling element forces generally depends on the contact angle and the number of rolling elements.

For the roller bearing the contact angle in the raceway system is zero. There is only axial pressure-force distribution here (no radial force) to the raceway and the rolling elements.

## Tilting moment $M_k$

An eccentric axial force  $F_a$  causes a tilting moment on the bearing by the lever arm. The resulting moment from all eccentric force applications is called tilting moment.

Depending on the eccentricity of the force application, different zones of the bearing are stressed. The pressure distribution to the raceway system is asymmetrical.

The highest pressure force affects the rolling element, which is located in the crest of the pressure-force distribution.

## Radial force $F_r$

The direction of the radial force runs perpendicular to the rotary axis of the bearing. The level of the force direction is almost in the rolling element centre.

Existing radial bearing loads are however only considered during the check of the static load-bearing capacity, if the radial load exceeds the value

$$F_r = 0.25 \times F_a \text{ (for four-point ball bearings)}$$

$$F_r = 0.10 \times F_a \text{ (for roller bearings).}$$

In these cases the static load-bearing capacity is checked by Liebherr.

## Graphic initial selection using the static limiting load curve

Each Liebherr large diameter bearing has an individual static limiting load curve depending on its dimensions, raceway geometry, type and number of rolling elements, as well as the ring material.

The static limiting load curve shows the maximum permissible values as a combination of axial force  $F_a$  and tilting moment  $M_k$ . This curve is simplified and shown as a straight line in the static limiting load diagram (abscissa:  $F_a$ ; ordinate:  $M_k$ ).

The values of the expected static load bearing are entered in

the limiting load diagram. The bearing is then statically suitable if the load point  $P_L (F_a, M_k)$  is below the static limiting load curve of the bearing selected by the user.

The limiting load curves are compiled as standard with bolts of strength category 10.9 i.a.w. DIN EN ISO 898-1 and a clamping length of  $l_k = 5 \times d$ . The tightening factor  $\alpha_A$  is 1.6, the preload is 70 %.

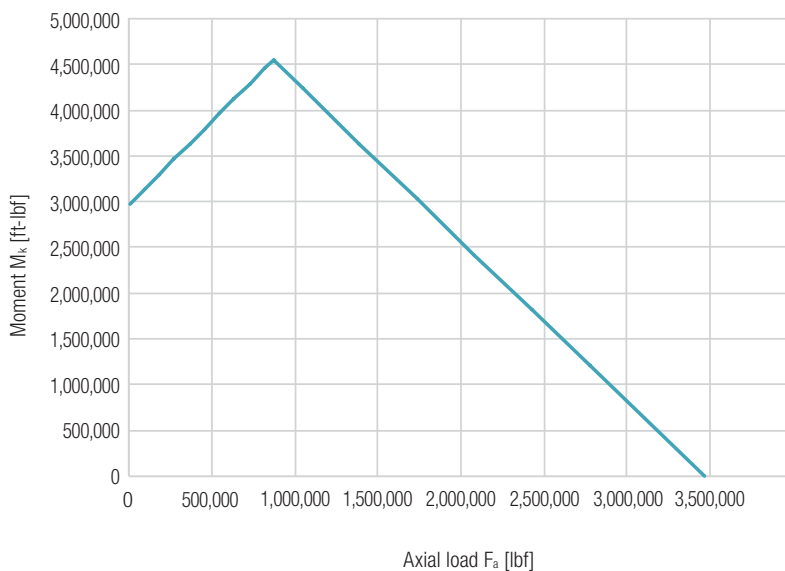

Image of a static limiting load diagram

The limiting load diagrams do not contain any reduction factors. They describe the performance of the bearing irrespective of the adjacent construction. It is assumed that an optimum installation situations is given.

## Calculation of the equivalent bearing load

Following the initial bearing selection, the static safety of the selected slewing bearing can be calculated. Using the equivalent load bearing  $P_0$  and the static load rating  $C_{stat}$  from the bearing tables for ball and roller bearing, these can be calculated using the following formulas.

### Ball bearing

$P_0$ :	equivalent axial load	[lbf]
$K_{rep}$ :	Load increase factor (see chapter 13, table "Influence factor $K_{rep}$ ")	
$f_1$ :	Load factor (see table "Load factor $f_1$ ")	
$F_a$ :	Axial load	[lbf]
$F_r$ :	Radial load	[lbf]
$M_k$ :	Tilting moment	[ft-lbf]
$D_L$ :	Raceway diameter	[ft]

$$P_0 = K_{rep} \times f_1 \left( F_a + 1.93 \times F_r + \frac{4 \times M_k}{D_L} \right)$$

### Load factor $f_1$

	$f_1$
Single-row ball bearing	1.0
Double-row ball bearing	1.4

With the static load rating from the bearing tables the static safety can be calculated as follows:

$$S_0 = \frac{C_{stat}}{P_0}$$

### Triple-row roller bearing (supporting raceway)

$P_0$ :	Equivalent axial load	[lbf]
$K_{rep}$ :	Load increase factor (see table "Influence factor $K_{rep}$ ")	
$F_a$ :	Axial load	[lbf]
$M_k$ :	Tilting moment	[ft-lbf]
$D_L$ :	Running thread diameter	[ft]

$$P_0 = K_{rep} \times 1.3 \left( F_a + \frac{4 \times M_k}{D_L} \right)$$

With the static load rating from the bearing tables the static safety can be calculated as follows:

$$S_0 = \frac{C_{stat}}{P_0}$$

# Example of static bearing selection

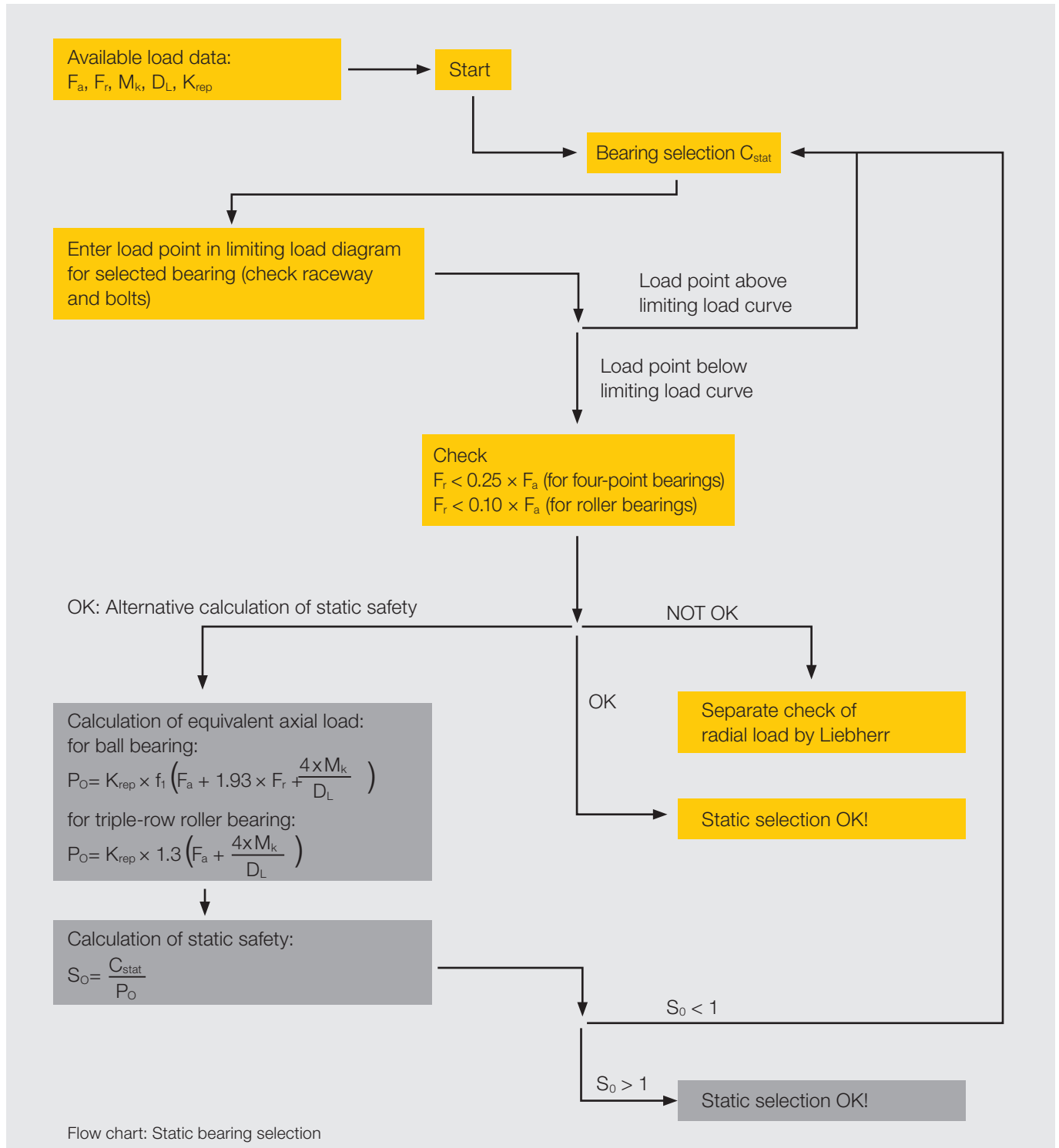

### Step 1:

A four-point ball bearing with external gear (**KUD02130-050VA**) is stressed with the following static load. The application is a **tower crane**.

$$M_k = 2,765,857 \text{ ft-lbf}$$

$$F_a = 449,618 \text{ lbf}$$

$$F_r = 40,466 \text{ lbf}$$

$$C_{\text{stat}} = 3,613,354 \text{ lbf}$$

$$K_{\text{rep}} = 1.3$$

$$D_L = 6.99 \text{ ft}$$

### Step 2:

The load combination is entered in the limiting load diagram for four-point ball bearings with external gear. The axial force  $F_a$  is plotted on the abscissa, the tilting moment  $M_k$  at the ordinate. The intersection point of the axial force and tilting moment gives the static load point  $P_L$ .

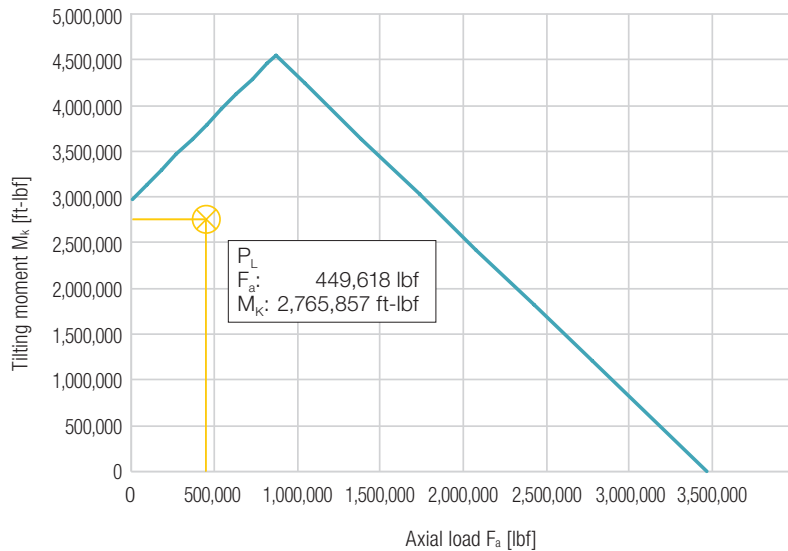

Selection example: KUD02130-050VA (static limiting load curve)

**Step 3:**

Checking the radial load:

$$\frac{F_r}{F_a} = \frac{40,466 \text{ lbf}}{449,618 \text{ lbf}} = 0.09 \leq 0.25$$

In the present case  $F_r < 0.25 \times F_a$ .

→ A separate check of the radial force by Liebherr is not required.

The load point  $P_L$  is below the static limiting load curve.

The bearing is therefore sufficiently dimensioned for these static loads.

To calculate the static safety continue with Step 4.

**Step 4:**

Calculation of equivalent axial load:

$$P_0 = 1.3 \times 1.0 \times \left( 449,618 \text{ lbf} + 1.93 \times 40,466 \text{ lbf} + \frac{4 \times 2,765,857 \text{ ft-lbf}}{6.99 \text{ ft}} \right) = 2,744,243 \text{ lbf}$$

**Step 5:**

Calculation of static safety:

$$S_0 = \frac{3,613,354 \text{ lbf}}{2,744,243 \text{ lbf}} = 1.32$$

**Result:**

The load point found is below the static limiting load curve for the bearing **KUD02130-050VA** and the static safety of 1.32 is greater than 1.0. The bearing is suitable for these static loads.



## 22 Dynamic bearing service life

For sizing a large diameter bearing, the expected service life from the stress of the operating loads is decisive, in addition to checking the static load-bearing capacity. This step can be omitted for bearings only under static stress.

The dynamic equivalent bearing load is calculated from the combination of axial force  $F_a$ , tilting moment  $M_k$  and radial load  $F_r$  on the bearing during the operation of the plant. The individual load components, the available load spectrum data and the relevant proportions of the overall duty cycle must be used for this calculation.

If there are multistage stresses or stresses made up of load spectrums, then these may be traced back to a single-stage equivalent dynamic bearing load using the elementary Miner Rule.

The equivalent dynamic bearing load is calculated 
$$P_{a_{\text{qui}}} = \left( \frac{\sum P_{a,i}^p \times U_i}{U_{\text{ges}}} \right)^{\frac{1}{p}} \text{ [lbf]}$$

with the respective equivalent axial loads of the individual load levels i:

### for ball bearings:

$$P_{a,i} = K_{\text{rep}}^{0.66} \times \left( F_{a,i} + 0.63 \times F_{r,i} + \frac{2 \times M_{k,i}}{D_L} \right) \text{ [lbf]}$$

### for triple-row roller bearings:

$$P_{a,i} = K_{\text{rep}}^{0.66} \times 1.4 \times \left( F_{a,i} + \frac{2 \times M_{k,i}}{D_L} \right) \text{ [lbf]}$$

$P_{a,i}$ :	Amount of equivalent axial load in the respective load level i	[lbf]
$U_i$ :	Number of bearing rotations of load level i	
$U_{\text{ges}}$ :	Total number of bearing rotations	
$p$ :	Service life exponent, gradient of Wöhler curve (for ball bearings $p = 3$ ; for all other bearings $p = 10/3$ )	
$F_{a,i}$ :	Axial load in load level	[lbf]
$F_{r,i}$ :	Radial load in load level	[lbf]
$M_{k,i}$ :	Tilting moment in load level	[ft-lbf]

Using the dynamic load rating and the equivalent bearing load, the bearing service life can be calculated for 10% probability of failure.

$$L_{10} = 10^6 \times \left( \frac{C_{\text{dyn}}}{P_{a_{\text{qui}}}} \right)^p$$

$C_{\text{dyn}}$ :	Dynamic load rating (take value from bearing tables)	[lbf]
--------------------	--	-------

# Influence of radial load

Existing radial bearing loads are however only considered during the check of the dynamic service life, if the radial load exceeds the value

$F_r = 0.25 \times F_a$  for four-point bearings or  
 $F_r = 0.10 \times F_a$  for roller bearings

**The dynamic service life is always also checked by Liebherr.**

## Sample calculation of dynamic bearing service life

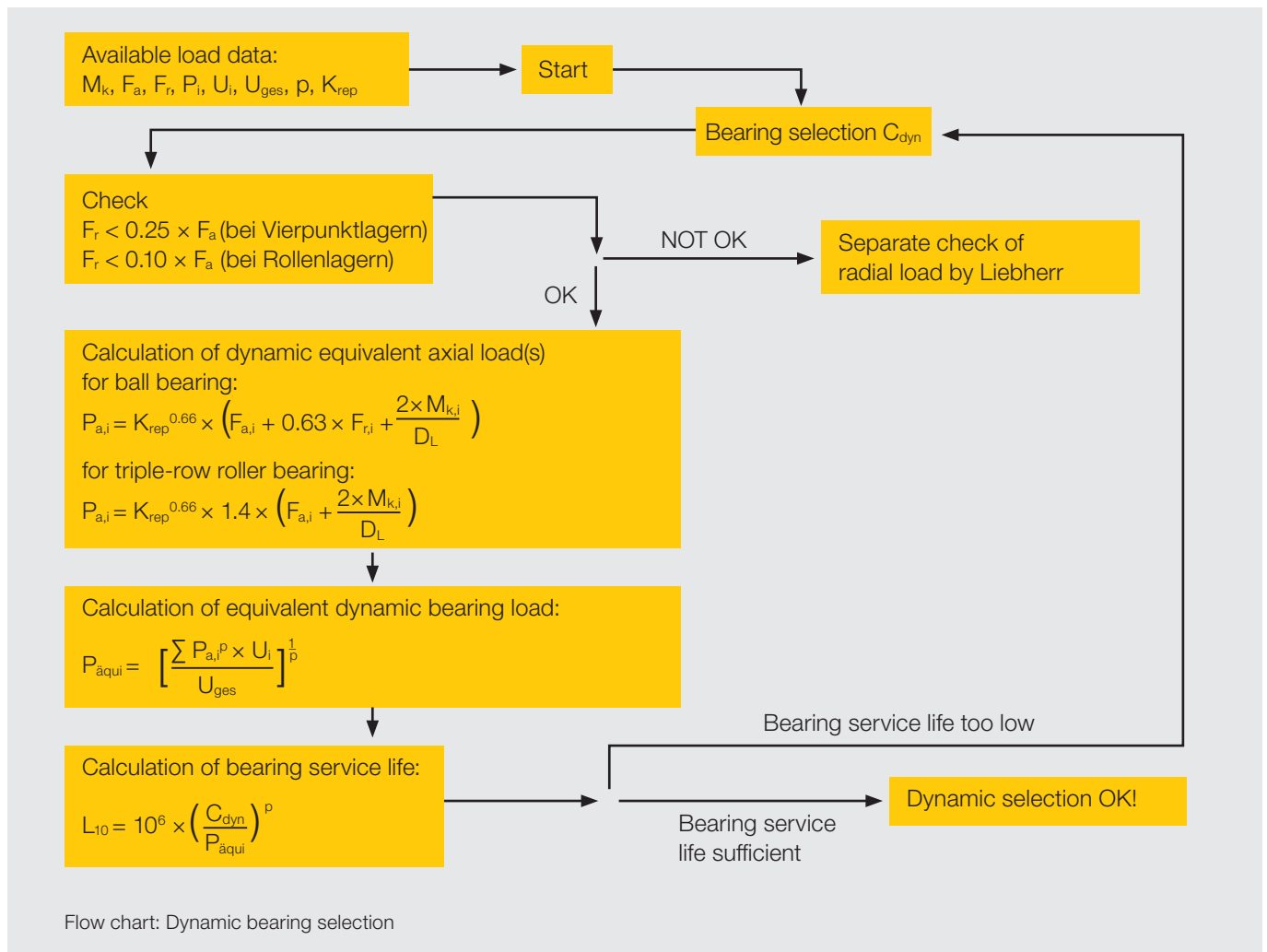

**Step 1:**

A four-point bearing with external gear (**KUD02130-050VA**) is stressed with the following dynamic load (load spectrum with load levels  $i=1$  and  $i=2$ ). The application is a **tower crane**.

$M_{k,1}$	= 1,843,905 ft-lbf	$U_2$	= 16,000
$F_{a,1}$	= 179,847 lbf	$U_{ges}$	= 20,300
$F_{r,1}$	= 11,240 lbf	$C_{dyn}$	= 279,662 lbf
$U_1$	= 4,300	$p$	= 3
$M_{k,2}$	= 700,684 ft-lbf	$K_{rep}$	= 1.3
$F_{a,2}$	= 157,366 lbf	$D_L$	= 6.99 ft
$F_{r,2}$	= 12,364 lbf		

**Step 2:**

Checking the radial loads:

$$\frac{F_{r,1}}{F_{a,1}} = \frac{11,240 \text{ lbf}}{179,847 \text{ lbf}} = 0.06 \leq 0.25$$

$$\frac{F_{r,2}}{F_{a,2}} = \frac{12,364 \text{ lbf}}{157,366 \text{ lbf}} = 0.08 \leq 0.25$$

In the present case  $F_r < 0.25 \times F_a$ .

-> A separate check of the radial force by Liebherr is not required.

**Step 3:**

Calculation of equivalent axial load(s):

$$P_{a,1} = 1.3^{0.66} \times \left( 179,847 \text{ lbf} + 0.63 \times 11,240 \text{ lbf} + \frac{2 \times 1,843,905 \text{ ft-lbf}}{6.99 \text{ ft}} \right) = 849,778 \text{ lbf}$$

$$P_{a,2} = 1.3^{0.66} \times \left( 157,366 \text{ lbf} + 0.63 \times 11,240 \text{ lbf} + \frac{2 \times 700,684 \text{ ft-lbf}}{6.99 \text{ ft}} \right) = 434,780 \text{ lbf}$$

**Step 4:**

Calculation of equivalent dynamic bearing load:

$$P_{\dot{a}qui} = \left( \frac{P_{a,1}^p \times U_1 + P_{a,2}^p \times U_2}{U_{ges}} \right)^{\frac{1}{p}}$$

$$P_{\dot{a}qui} = \left( \frac{(849,778 \text{ lbf})^3 \times 4,300 + (434,780 \text{ lbf})^3 \times 16,000}{20,300} \right)^{\frac{1}{3}} = 579,557 \text{ lbf}$$

**Step 5:**

Calculation of bearing service life:

$$L_{10} = 10^6 \times \left( \frac{279,662 \text{ lbf}}{579,557 \text{ lbf}} \right)^3 = 112,303 \text{ [rotations]}$$

**Result:**

The calculated bearing service life under the aforementioned operating conditions with 10% probability of failure is 112,303 rotations.

The bearing service life is thus above the prescribed 20,300 rotations, therefore the indicated load spectrum can be applied to this bearing.

## Circumferential speed

Liebherr slewing bearings must be used up to a circumferential speed of 13.1 ft/sec. For higher circumferential speeds, special rolling element guides or cages are required. Deviations must be clarified with Liebherr.

## 23 Rotation resistance of bearing

Like every anti-friction bearing, large diameter bearings also have frictional resistance. The resistance, which an anti-friction bearing offers to its rotation, is made up of rolling friction, dynamic friction and lubricant friction.

**Rolling friction** occurs when the rolling elements roll onto the raceways. The friction between the rolling elements and the raceway profile increases with narrowing osculation and load.

**Dynamic friction** occurs both at the contact surfaces of the rolling elements in the cage or at the spacers (for roller bearings also at the bearing ribs and the roller end faces) and at the seal running surfaces.

Under normal operating conditions and with sufficient lubrication, the frictional resistance is low. Inadequate lubrication, dirt contamination and high speeds may noticeably increase the dynamic friction and lead to increased wear.

The **lubricant** friction results, on the one hand, from the inner friction of the lubricant, and, on the other hand, from the flexing during the movement of the bearing.

The entire lubricant friction essentially depends on the viscosity and the quantity of the lubricant. The impact is small at low speeds.

The friction torque for an unloaded and unscrewed bearing is the assembly friction torque  $M_0$ .

$M_E$  describes the installation torque of the bearing (fastened together). It mainly results from the lubricant friction, the friction of the rolling elements, the friction of the spacers (or cages) and the seals, and essentially depends on the design and size of the bearing.

$$M_E = f_s \times W_R \times D_L^2$$

$M_{RN}$  describes the load-dependent proportion of the overall friction torque. This part is dependent on the present load, the rotational velocity of the bearing, as well as the properties of the adjacent construction.

$$M_{RN} = k \times \mu \times f_A \times 0.95 \times e^{(0.15 \times n_{GWL})} \times \left( M_k + \frac{f_L \times F_R \times D_L}{2} + \frac{F_A \times D_L}{k} \right)$$

**For the overall friction torque of the large diameter bearing, the following applies:**

$$M_{Reib} = M_E + M_{RN}$$

**Liebherr formula of friction moment:**

$$M_{Reib} = f_s \times W_R \times D_L^2 + k \times \mu \times f_A \times 0.95 \times e^{(0.15 \times n_{GWL})} \times \left( M_k + \frac{f_L \times F_R \times D_L}{2} + \frac{F_A \times D_L}{k} \right) \text{ [ft-lbf]}$$

$f_s$ :	Bolt connection factor	see table "Bolt connection factor"
$W_R$ :	Specific friction force	[lbf/ft] see table "Specific friction force"
$D_L$ :	Raceway diameter	[ft]
$k$ :	K-factor	see table "k-factor"
$f_A$ :	Adjacent construction factor	see table "Adjacent construction factor"
$n_{GWL}$ :	Speed of the large diameter bearing	[rpm]
$f_L$ :	Raceway factor	$f_L = 1.73$ (constant)
$\mu$ :	Friction coefficient	see table "Friction values"
$F_A$ :	Axial load	[lbf]
$F_R$ :	Radial load	[lbf]

## Friction coefficients

Type of slewing bearing	Friction coefficient $\mu$
KUD_V (four-point ball bearing)	0.003
KUD_W (double-row four-point ball bearing)	0.003
KUD_Z (double-row)	0.002
ROD_D (triple-row)	0.0015
RKD	0.0015

<sup>1</sup> All listed slewing bearings in this catalogue are carried out with spacers.

## Factors for bolt connection

Type of slewing bearing	Bolt connection factor $f_s$
KUD_V (four-point ball bearing)	1.0
KUD_W (double-row four-point ball bearing)	1.0
KUD_Z (double-row)	1.0
ROD_D (triple-row)	1.0
RKD	1.0

## Factor for the adjacent construction

Application	Adjacent construction factor $f_A$
Homogeneous and rigid adjacent construction (ideal)	1.0

In case of a not ideal adjacent construction (ideal adjacent construction see page 29) the factor  $f_A$  has to be customized depending on the application case.

## Specific friction forces

Type of slewing bearing	specific friction force $W_R$ [lbf/ft]
KUD_V (four-point ball bearing)	125.395
KUD_W (double-row four-point ball bearing)	134.303
KUD_Z (double-row)	119.228
ROD_D (triple-row)	104.838
RKD	104.838

## k-factors

Type of slewing bearing	Factor k
KUD_V (four-point ball bearing)	1.25
KUD_W (double-row four-point ball bearing)	1.25
KUD_Z (double-row)	1.25
ROD_D (triple-row)	1.17
RKD	1.17

Values only apply to standard bearings with standard seals, for special bearings the values must be calculated in each case.

For unloaded bearings or bearings with low loads, the calculated values may deviate considerably from the actual values.

The necessary acceleration power, occurring wind loads and any inclined position of the bearing axis must also be considered in the sizing of the drive.

For special requirements of the rotation resistance of the large diameter bearing, corresponding adaptations can be made to increase or reduce the rotation resistance after consultation with Liebherr.

# 24 Drive torque required

In order to operate the selected large diameter bearing with the present load spectrum, the following torque is required at the pinion of the gearbox:

$$M_{\text{pinion, req.}} = M_{\text{friction}} \times i_{\text{pinion/bearing}} \times \eta_{\text{pinion/bearing}} \times 1,000 \text{ [ft-lbf]}$$

$$i_{\text{pinion/bearing}}: \text{Transmission ratio pinion/bearing} = \frac{Z_{\text{pinion}}}{Z_{\text{bearing}}} \quad (\text{number of teeth})$$

$$\eta_{\text{pinion/bearing}}: \text{Efficiency of gearing pinion/bearing} = 0.99 \quad (\text{spur gearing})$$

On the basis of the value calculated above  $M_{\text{pinion, req.}}$ , a suitable slewing drive can be selected from the table "Technical data of the series designs DAT".

For the static selection of the drive, the maximum torque  $T_{\text{Max}}$  (includes 1.5x tooth fracture safety) from the table of Liebherr slewing drives must be used. A size for the gearbox can be determined here. For the dynamic selection of the drive, the dynamic output torque  $T_{\text{FEM}}$  is used. This value refers to the load spectrum M5/L2/T5 (max. 6,300 collective hours or 1,600 full-load hours) at 10 rpm from the "FEM 1.001 Calculation basis for cranes". Other load spectrums for other applications may reveal a different torque value for the gearbox. This must be checked by Liebherr in each case.



## Technical data of the series designs DAT

	DAT 200	DAT 225	DAT 250	DAT 300	DAT 350	DAT 400
$T_{\text{FEM}}$ [ft-lbf]	3,687	5,900	8,113	13,276	22,126	32,453
$T_{\text{MAX}}$ [ft-lbf]	7,375	11,800	16,226	26,552	44,254	64,905

$T_{\text{FEM}}$  = Reference torque  $T_{\text{FEM}}$  based on M5/L2/T5 at 10 rpm at the output

$T_{\text{Max}}$  = Security >1.5 against fracture

## Inertia factor

The inertia factor to be overcome  $P_B$  can be calculated:

$$P_B = M_{\text{Reib}} \times \omega \times \eta^{-1} = \frac{M_{\text{Reib}} \times n}{9.55 \times \eta} \text{ [ft-lbf/min]}$$

$$\omega: \text{Angular velocity } \omega = \frac{\pi \times n}{30} \text{ [s-1]}$$

**n:** Required rotational velocity of large diameter bearing [rpm]

**$\eta$ :** Efficiency of drive (gearbox with engine)



on request

DAT 450	DAT 500	DAT 600	DAT 700	DAT 800	DAT 1000
44,254	60,480	104,734	154,888	228,644	449,913
88,507	118,010	209,468	309,776	457,289	899,826

# 25 Glossary

KUD 00855 - 025 V A 15 - 900 - 000

## Product group

- KUD - Ball bearing
- ROD - Roller bearing (cylindrical rollers)
- RKD - Combined roller and ball bearing

## Raceway diameter (mm)

## Roller element diameter (mm)

## Type

- Z - double-row
- D - triple-row
- V - four-point bearing
- W - double-row four-point bearing

## Gearing

- O - no gearing
- J - inner gearing
- A - outer gearing

## Internal designation



KUD\_V

Ball bearings; four-point contact

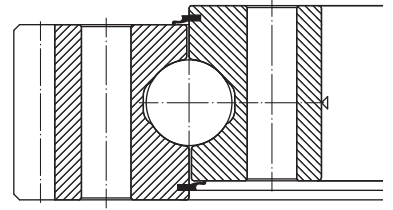

KUD\_Z

Double-row ball bearings

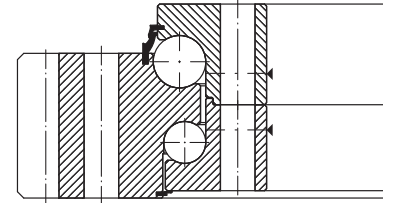

KUD\_W

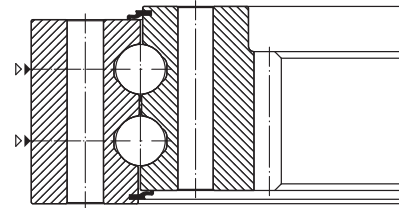
Double-row ball bearings;  
four-point contact

ROD\_D

Triple-row roller bearings\*

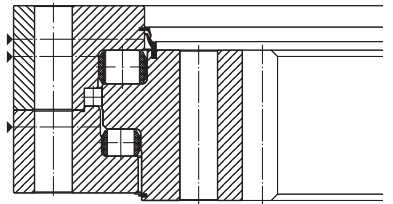

ROD\_D

Triple-row roller bearings

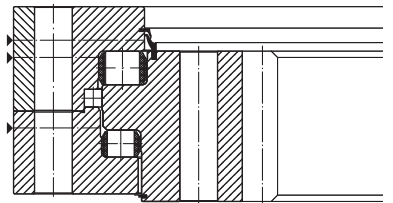
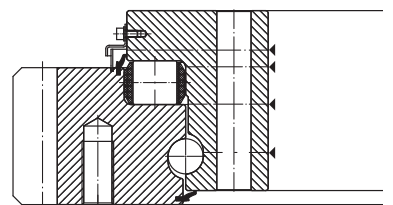
RKD Combined roller  
and ball bearings

\* Shorter delivery times can be realized.



## 26 Standard range - Technical data

KUD\_V Ball bearings; four-point contact

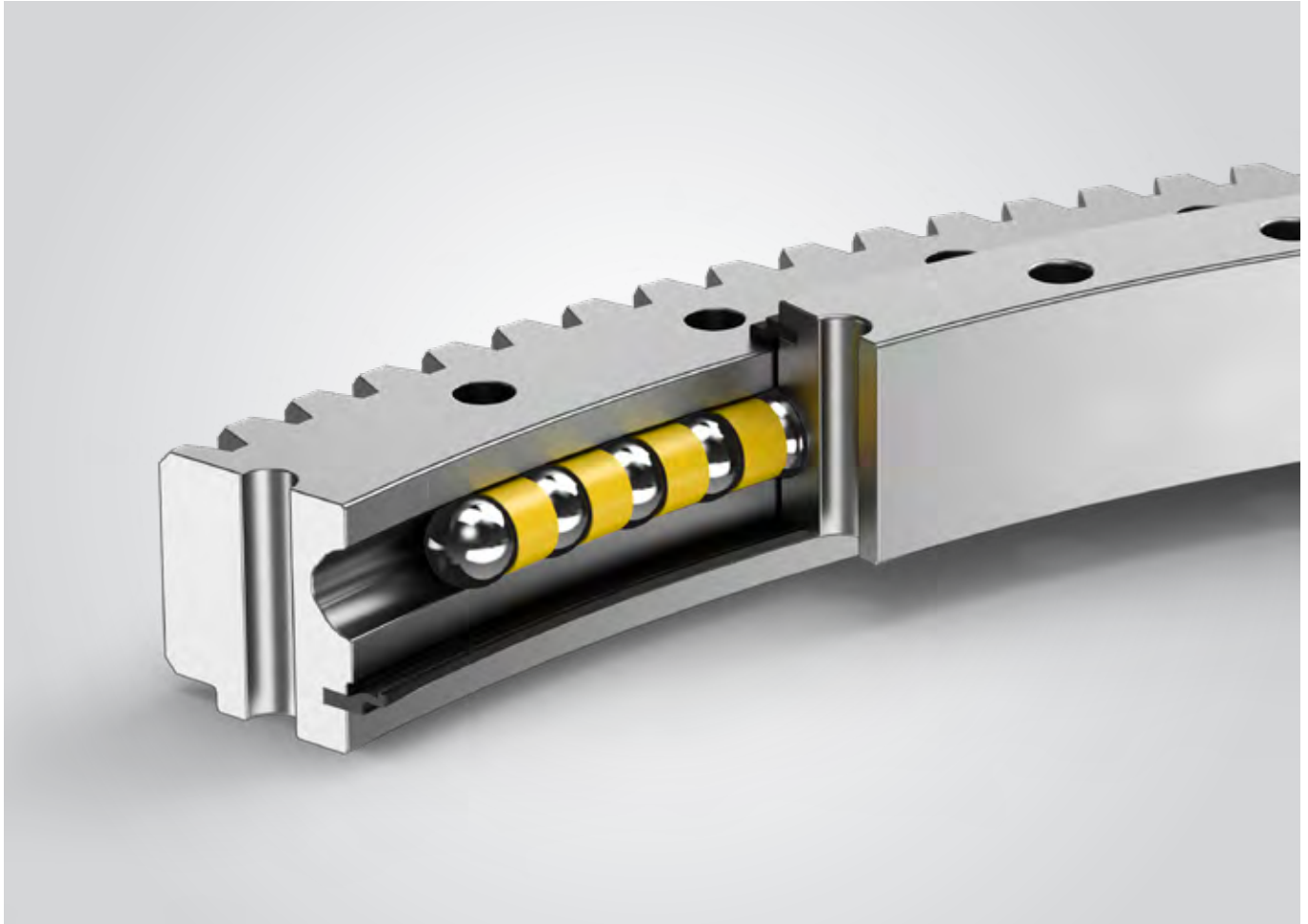

**KUD\_VA**

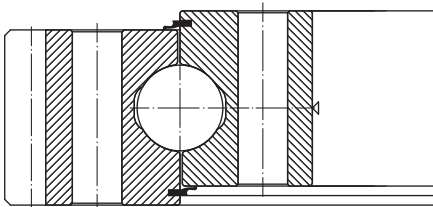

**KUD\_VJ**

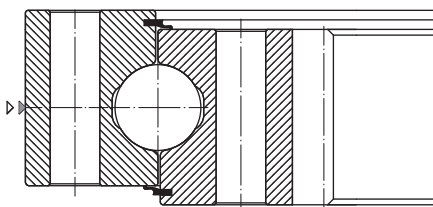

**KUD\_VO**

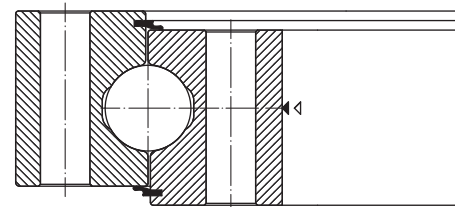

## External gear KUD\_25\_VA

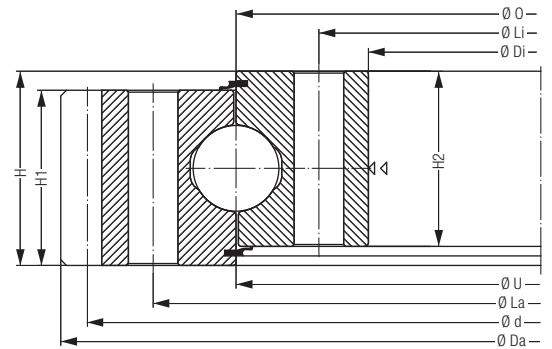
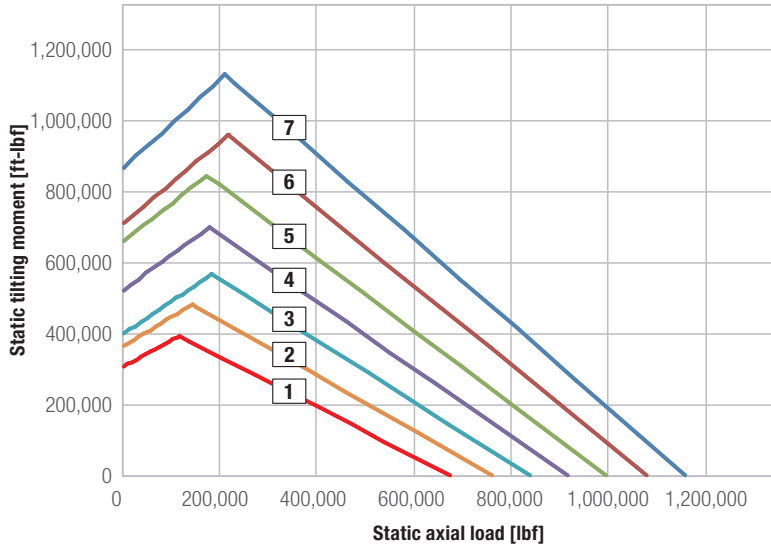

- 1 KUD00855-025VA15-900-000
- 2 KUD00955-025VA15-900-000
- 3 KUD01055-025VA15-900-000
- 4 KUD01155-025VA15-900-000
- 5 KUD01255-025VA15-900-000
- 6 KUD01355-025VA15-900-000
- 7 KUD01455-025VA15-900-000

Bearing type	Bearing data								Bolt data					Gear data							Load rating		
	Weight	Outer diameter	Inner diameter	Total height	Outer diameter Inner ring	Inner diameter Outer ring	Height Outer ring	Height Inner ring	Pitch circle diameter Outer ring	Pitch circle diameter Inner ring	Number of bores per ring	Bolt diameter	Number of grease nipples per level	Pitch circle diameter	Module (metric)	Number of teeth	Profile shift	Tip reduction	Tooth width	Tooth forces (standard)	Tooth forces (maximum)	static	dynamic
	[lbs]	[inch]	[inch]	[inch]	[inch]	[inch]	[inch]	[inch]	[inch]	[inch]		[mm]		[inch]	[mm]		[inch]	[inch]	[inch]	[lbf]	[lbf]	$C_{stat}$	$C_{dyn}$
1	310.2	39.26	29.72	3.15	33.66	33.66	2.80	2.13	36.06	31.30	28	20	4	38.62	9	109	-	-0.035	2.80	7,470.4	14,940.8	675,326	95,094
2	347.6	43.16	33.66	3.15	37.60	37.60	2.80	2.13	40.00	35.24	30	20	6	42.52	9	120	-	-0.035	2.80	7,470.4	14,940.8	760,529	99,590
3	378.4	47.17	37.60	3.15	41.54	41.54	2.80	2.13	43.94	39.17	30	20	6	46.46	10	118	-	-0.039	2.80	8,299.9	16,599.9	838,762	103,187
4	418	51.10	41.54	3.15	45.47	45.47	2.80	2.13	47.87	43.11	36	20	6	50.39	10	128	-	-0.039	2.80	8,299.9	16,599.9	916,996	106,559
5	448.8	55.04	45.47	3.15	49.41	49.41	2.80	2.13	51.81	47.05	42	20	6	54.33	10	138	-	-0.039	2.80	8,299.9	16,599.9	995,229	109,932
6	488.4	58.98	49.41	3.15	53.35	53.35	2.80	2.13	55.75	50.98	42	20	6	58.27	10	148	-	-0.039	2.80	8,299.9	16,599.9	1,080,432	113,529
7	519.2	62.91	53.35	3.15	57.28	57.28	2.80	2.13	59.69	54.92	48	20	6	62.20	10	158	-	-0.039	2.80	8,299.9	16,599.9	1,158,665	116,451

## External gear KUD\_25\_VA

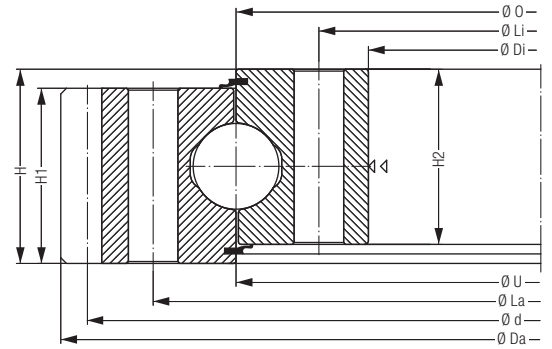
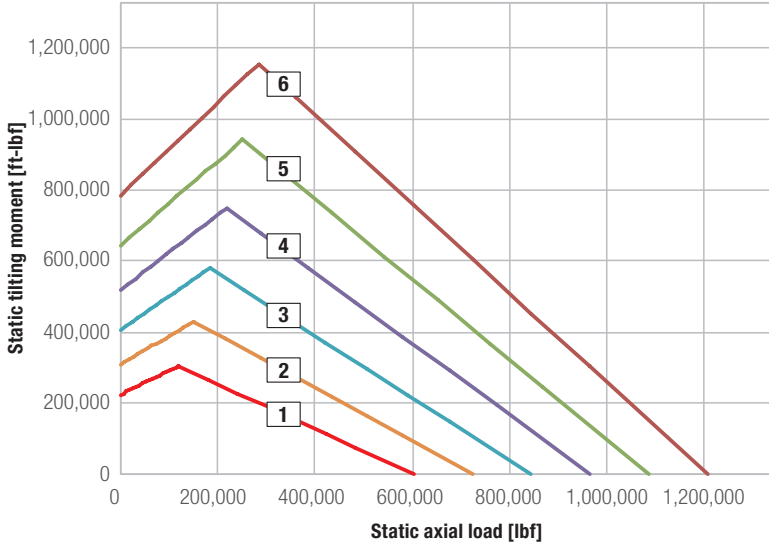

- 1 KUD00762-025VA15-900-000
- 2 KUD00914-025VA15-900-000
- 3 KUD01067-025VA15-900-000
- 4 KUD01219-025VA15-900-000
- 5 KUD01372-025VA15-900-000
- 6 KUD01524-025VA15-900-000

Bearing type	Bearing data								Bolt data					Gear data							Load rating		
	Weight	Outer diameter	Inner diameter	Total height	Outer diameter Inner ring	Inner diameter Outer ring	Height Outer ring	Height Inner ring	Pitch circle diameter Outer ring	Pitch circle diameter Inner ring	Number of bores per ring	Bolt diameter	Number of grease nipples per level	Pitch circle diameter	Diametral Pitch	Number of teeth	Profile shift	Tip reduction	Tooth width	Tooth forces (standard)	Tooth forces (maximum)	static	dynamic
	[lbs]	Da [inch]	Di [inch]	H [inch]	O [inch]	U [inch]	H1 [inch]	H2 [inch]	La [inch]	Li [inch]	n	M [inch]	n1	d [inch]	Pd [mm]	z	x*m [inch]	k*m [inch]	b [inch]	[lbf]	[lbf]	C <sub>stat</sub> [lbf]	C <sub>dyn</sub> [lbf]
1	398	35.84	24.00	3.50	30.00	30.00	3.00	3.00	32.75	26.75	24/30	3/4" - 10 UNC	4	35.20	2.5	88	-	-	3.00	9,196.5	18,393.0	618,449	92,846
2	481	41.84	30.00	3.50	35.98	35.98	3.00	3.00	38.75	32.75	28/32	3/4" - 10 UNC	6	41.20	2.5	103	-	-	3.00	9,304.0	18,608.0	746,366	99,590
3	562	47.84	36.00	3.50	42.01	42.01	3.00	3.00	44.75	38.75	32/36	3/4" - 10 UNC	6	47.20	2.5	118	-	-	3.00	9,386.0	18,772.0	874,282	105,885
4	660	53.84	42.00	3.50	47.99	47.99	3.00	3.00	50.75	44.75	36/40	3/4" - 10 UNC	6	53.20	2.5	133	-	-	3.00	9,450.5	18,901.0	995,229	110,831
5	742	59.84	48.00	3.50	54.02	54.02	3.00	3.00	56.75	50.75	40/44	3/4" - 10 UNC	6	59.20	2.5	148	-	-	3.00	9,502.5	19,005.0	1,123,145	116,001
6	800	65.84	54.00	3.50	60.00	60.00	3.00	3.00	62.75	56.75	44/48	3/4" - 10 UNC	6	65.20	2.5	163	-	-	3.00	9,545.0	19,090.0	1,243,868	120,273

## External gear KUD\_30\_VA

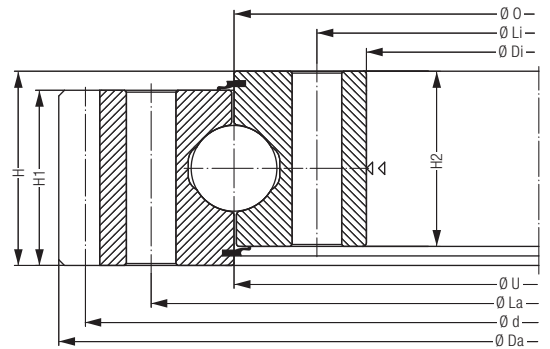
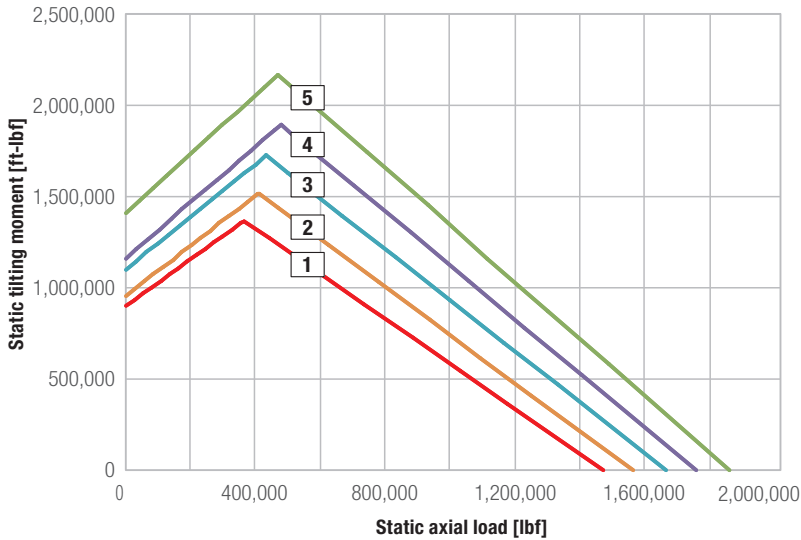

- 1 KUD01500-030VA15-900-000
- 2 KUD01600-030VA15-900-000
- 3 KUD01700-030VA15-900-000
- 4 KUD01800-030VA15-900-000
- 5 KUD01900-030VA15-900-000

Bearing type	Bearing data								Bolt data					Gear data							Load rating		
	Weight	Outer diameter	Inner diameter	Total height	Outer diameter Inner ring	Inner diameter Outer ring	Height Outer ring	Height Inner ring	Pitch circle diameter Outer ring	Pitch circle diameter Inner ring	Number of bores per ring	Bolt diameter	Number of grease nipples per level	Pitch circle diameter	Module (metric)	Number of teeth	Profile shift	Tip reduction	Tooth width	Tooth forces (standard)	Tooth forces (maximum)	static	dynamic
	[lbs]	[inch]	[inch]	[inch]	[inch]	[inch]	[inch]	[inch]	[inch]	[inch]		[mm]		[inch]	[mm]		[inch]	[inch]	[inch]	[lbf]	[lbf]	[lbf]	[lbf]
	Da	Di	H	O	U	H1	H2	La	Li	n	M	n1	d	m	z	x*m	k*m	b			C <sub>stat</sub>	C <sub>dyn</sub>	
1	677.6	65.57	54.80	3.31	59.06	59.06	2.83	2.83	61.57	56.54	48	20	6	64.25	12	136	0.24	-0.047	2.83	17,827.3	35,656.9	1,473,847	145,676
2	710.6	69.35	58.74	3.31	62.99	62.99	2.83	2.83	65.51	60.47	48	20	6	68.03	12	144	0.24	-0.047	2.83	17,827.3	35,656.9	1,566,019	148,824
3	785.4	73.61	62.68	3.31	66.93	66.93	2.83	2.83	69.45	64.41	52	20	7	72.28	12	153	0.24	-0.047	2.83	17,827.3	35,656.9	1,668,307	152,420
4	818.4	77.39	66.61	3.31	70.87	70.87	2.83	2.83	73.39	68.35	52	20	7	76.06	12	161	0.24	-0.047	2.83	17,827.3	35,656.9	1,760,479	155,343
5	842.6	81.17	70.55	3.31	74.80	74.80	2.83	2.83	77.32	72.28	60	20	8	79.84	12	169	0.24	-0.047	2.83	17,827.3	35,656.9	1,862,767	158,715

## External gear KUD\_35\_VA

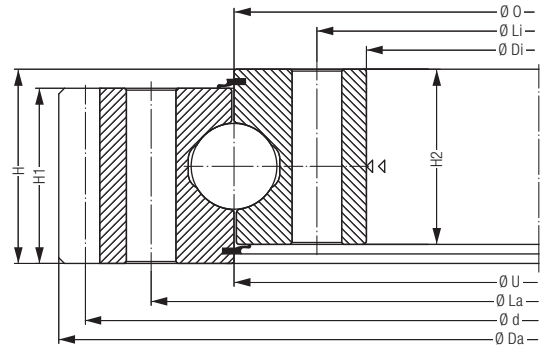
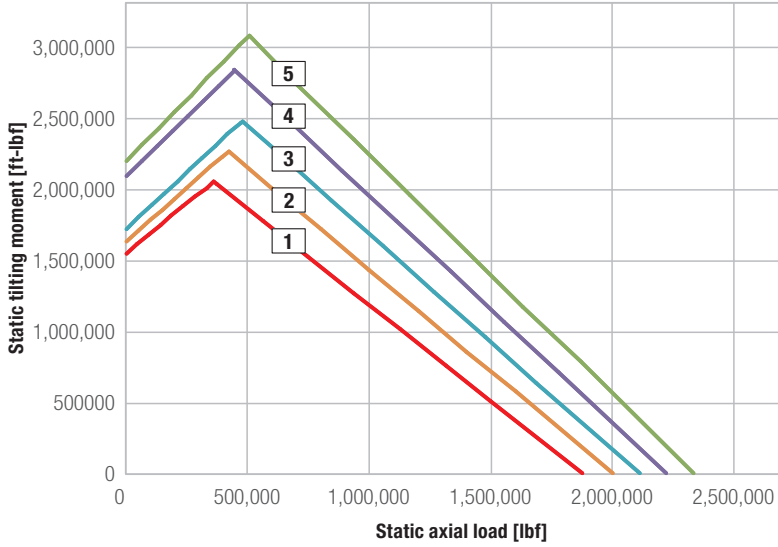

- 1 KUD01650-035VA15-900-000
- 2 KUD01750-035VA15-900-000
- 3 KUD01850-035VA15-900-000
- 4 KUD01950-035VA15-900-000
- 5 KUD02050-035VA15-900-000

Bearing type	Bearing data								Bolt data					Gear data							Load rating		
	Weight	Outer diameter	Inner diameter	Total height	Outer diameter Inner ring	Inner diameter Outer ring	Height Outer ring	Height Inner ring	Pitch circle diameter Outer ring	Pitch circle diameter Inner ring	Number of bores per ring	Bolt diameter	Number of grease nipples per level	Pitch circle diameter	Module (metric)	Number of teeth	Profile shift	Tip reduction	Tooth width	Tooth forces (standard)	Tooth forces (maximum)	static	dynamic
	[lbs]	[inch]	[inch]	[inch]	[inch]	[inch]	[inch]	[inch]	[inch]	[inch]		[mm]		[inch]	[mm]		[inch]	[inch]	[inch]	[lbf]	[lbf]	$C_{stat}$	$C_{dyn}$
<b>1</b>	961.4	72.19	59.96	3.70	64.96	64.96	3.23	3.23	67.91	62.01	52	24	7	70.87	12	150	0.236	-0.047	3.23	20,304.7	40,609.5	1,880,752	176,250
<b>2</b>	1,005.4	75.97	63.90	3.70	68.90	68.90	3.23	3.23	71.85	65.94	52	24	7	74.65	12	158	0.236	-0.047	3.23	20,304.7	40,609.5	2,006,195	180,746
<b>3</b>	1,104.4	80.22	67.83	3.70	72.83	72.83	3.23	3.23	75.79	69.88	52	24	7	78.90	12	167	0.236	-0.047	3.23	20,304.7	40,609.5	2,117,700	184,343
<b>4</b>	1,135.2	84.00	71.77	3.70	76.77	76.77	3.23	3.23	79.72	73.82	60	24	8	82.68	12	175	0.236	-0.047	3.23	20,304.7	40,609.5	2,228,981	187,715
<b>5</b>	1,269.4	88.63	75.71	3.70	80.71	80.71	3.23	3.23	83.66	77.76	60	24	8	87.09	14	158	0.276	-0.055	3.23	23,688.1	47,376.2	2,340,486	191,088

## External gear KUD\_40\_VA

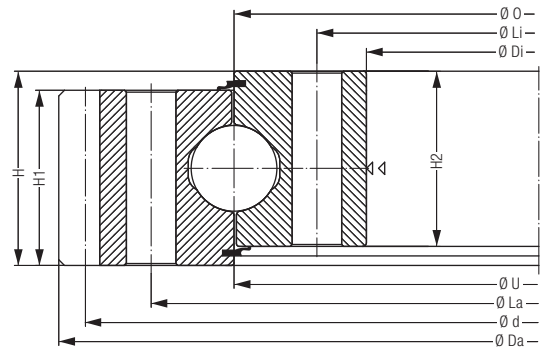
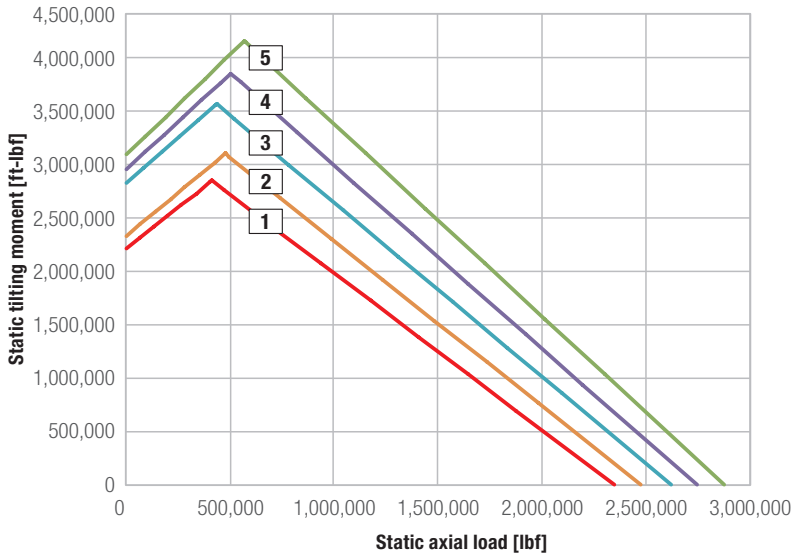

- 1 KUD01800-040VA15-900-000
- 2 KUD01900-040VA15-900-000
- 3 KUD02000-040VA15-900-000
- 4 KUD02100-040VA15-900-000
- 5 KUD02200-040VA15-900-000

Bearing type	Bearing data								Bolt data					Gear data						Load rating			
	Weight	Outer diameter	Inner diameter	Total height	Outer diameter Inner ring	Inner diameter Outer ring	Height Outer ring	Height Inner ring	Pitch circle diameter Outer ring	Pitch circle diameter Inner ring	Number of bores per ring	Bolt diameter	Number of grease nipples per level	Pitch circle diameter	Module (metric)	Number of teeth	Profile shift	Tip reduction	Tooth width	Tooth forces (standard)	Tooth forces (maximum)	static	dynamic
	[lbs]	[inch]	[inch]	[inch]	[inch]	[inch]	[inch]	[inch]	[inch]	[inch]		[mm]	n1	d	m	z	x*m	k*m	b	[lbf]	[lbf]	C <sub>stat</sub>	C <sub>dyn</sub>
1	1,311.2	78.80	65.16	4.09	70.87	70.87	3.62	3.62	74.21	67.52	52	27	7	77.48	12	164	0.236	-0.047	3.62	22,779.9	45,562.0	2,347,455	208,848
2	1,368.4	82.58	69.09	4.09	74.80	74.80	3.62	3.62	78.15	71.46	52	27	7	81.26	12	172	0.236	-0.047	3.62	22,779.9	45,562.0	2,474,697	212,894
3	1,471.8	86.98	73.03	4.09	78.74	78.74	3.62	3.62	82.09	75.39	60	27	7	85.43	14	155	0.276	-0.055	3.62	26,576.9	53,153.8	2,620,373	217,840
4	1,540.0	90.83	76.97	4.09	82.68	82.68	3.62	3.62	86.02	79.33	60	27	8	89.29	14	162	0.276	-0.055	3.62	26,576.9	53,153.8	2,747,615	221,662
5	1,606.0	94.69	80.91	4.09	86.61	86.61	3.62	3.62	89.96	83.27	60	27	8	93.15	14	169	0.276	-0.055	3.62	26,576.9	53,153.8	2,875,082	225,259



## External gear KUD\_45\_VA

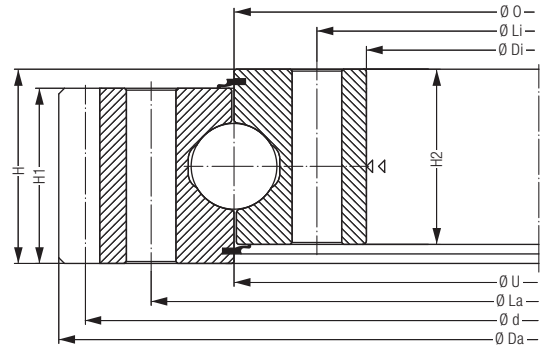
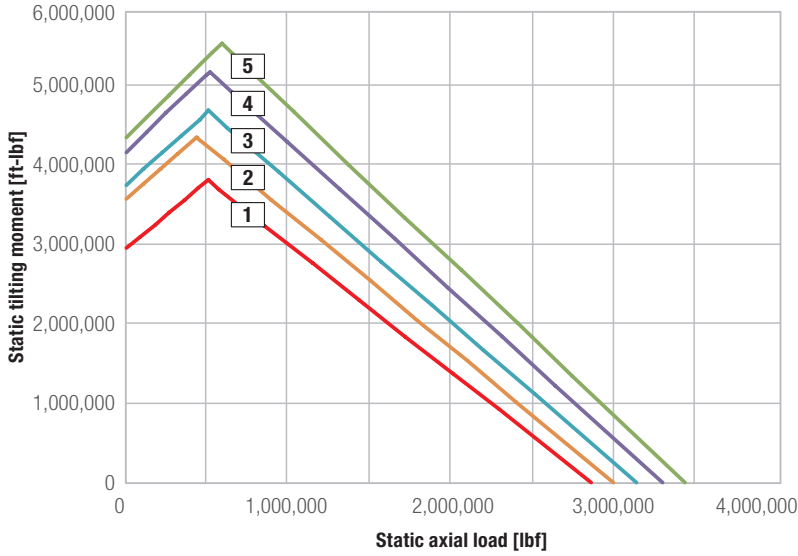

- 1 KUD01950-045VA15-900-000
- 2 KUD02050-045VA15-900-000
- 3 KUD02150-045VA15-900-000
- 4 KUD02250-045VA15-900-000
- 5 KUD02350-045VA15-900-000

Bearing type	Bearing data								Bolt data					Gear data							Load rating		
	Weight	Outer diameter	Inner diameter	Total height	Outer diameter Inner ring	Inner diameter Outer ring	Height Outer ring	Height Inner ring	Pitch circle diameter Outer ring	Pitch circle diameter Inner ring	Number of bores per ring	Bolt diameter	Number of grease nipples per level	Pitch circle diameter	Module (metric)	Number of teeth	Profile shift	Tip reduction	Tooth width	Tooth forces (standard)	Tooth forces (maximum)	static	dynamic
	[lbs]	[inch]	[inch]	[inch]	[inch]	[inch]	[inch]	[inch]	[inch]	[inch]		[mm]	n1	d	m	z	x*m	k*m	b	[lbf]	[lbf]	C <sub>stat</sub>	C <sub>dyn</sub>
1	1,735.8	85.42	70.43	4.49	76.77	76.77	4.02	4.02	80.51	73.03	52	30	8	84.09	12	178	0.236	-0.047	4.02	25,257.3	50,514.6	2,878,903	243,918
2	1,845.8	89.73	74.37	4.49	80.71	80.71	4.02	4.02	84.45	76.97	60	30	8	88.19	14	160	0.276	-0.055	4.02	29,465.7	58,931.4	3,016,936	247,964
3	1,929.4	93.59	78.31	4.49	84.65	84.65	4.02	4.02	88.39	80.91	60	30	8	92.05	14	167	0.276	-0.055	4.02	29,465.7	58,931.4	3,155,194	251,786
4	1,999.8	97.45	82.24	4.49	88.58	88.58	4.02	4.02	92.32	84.84	64	30	9	95.91	14	174	0.276	-0.055	4.02	29,465.7	58,931.4	3,316,382	256,957
5	2,083.4	101.31	86.18	4.49	92.52	92.52	4.02	4.02	96.26	88.78	64	30	9	99.76	14	181	0.276	-0.055	4.02	29,465.7	58,931.4	3,454,414	260,554

## External gear KUD\_50\_VA

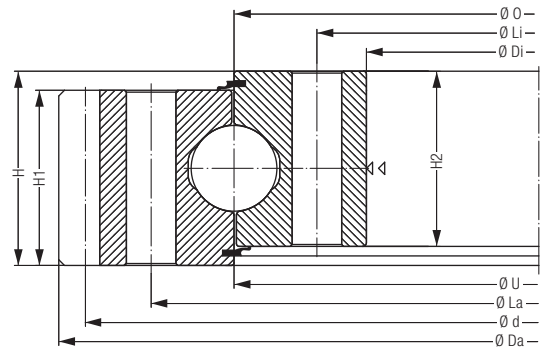
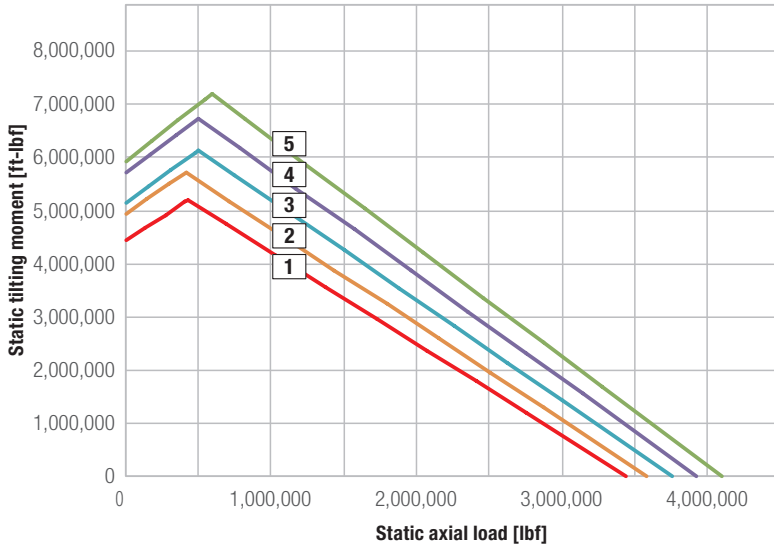

- 1 KUD02100-050VA15-900-000
- 2 KUD02200-050VA15-900-000
- 3 KUD02300-050VA15-900-000
- 4 KUD02400-050VA15-900-000
- 5 KUD02500-050VA15-900-000

Bearing type	Bearing data								Bolt data					Gear data							Load rating		
	Weight	Outer diameter	Inner diameter	Total height	Outer diameter Inner ring	Inner diameter Outer ring	Height Outer ring	Height Inner ring	Pitch circle diameter Outer ring	Pitch circle diameter Inner ring	Number of bores per ring	Bolt diameter	Number of grease nipples per level	Pitch circle diameter	Module (metric)	Number of teeth	Profile shift	Tip reduction	Tooth width	Tooth forces (standard)	Tooth forces (maximum)	static	dynamic
	[lbs]	Da [inch]	Di [inch]	H [inch]	O [inch]	U [inch]	H1 [inch]	H2 [inch]	La [inch]	Li [inch]	n	M	n1	d [inch]	m [mm]	z	x*m [inch]	k*m [inch]	b [inch]			C <sub>stat</sub> [lbf]	C <sub>dyn</sub> [lbf]
1	2,263.8	92.49	75.75	4.88	82.68	82.68	4.41	4.41	86.77	78.58	60	33	8	90.94	14	165	0.276	-0.055	4.41	30,331.2	64,711.3	3,440,476	279,213
2	2,349.6	96.35	79.69	4.88	86.61	86.61	4.41	4.41	90.71	82.52	64	33	8	94.80	14	172	0.276	-0.055	4.41	30,331.2	64,711.3	3,582,555	282,810
3	2,450.8	100.20	83.62	4.88	90.55	90.55	4.41	4.41	94.65	86.46	64	33	8	98.66	14	179	0.276	-0.055	4.41	30,331.2	64,711.3	3,753,185	287,980
4	2,534.4	104.06	87.56	4.88	94.49	94.49	4.41	4.41	98.58	90.39	68	33	10	102.52	14	186	0.276	-0.055	4.41	30,331.2	64,711.3	3,923,590	292,926
5	2,633.4	107.92	91.50	4.88	98.43	98.43	4.41	4.41	102.52	94.33	68	33	10	106.38	14	193	0.276	-0.055	4.41	30,331.2	64,711.3	4,094,220	297,647

## External gear KUD\_50\_VA

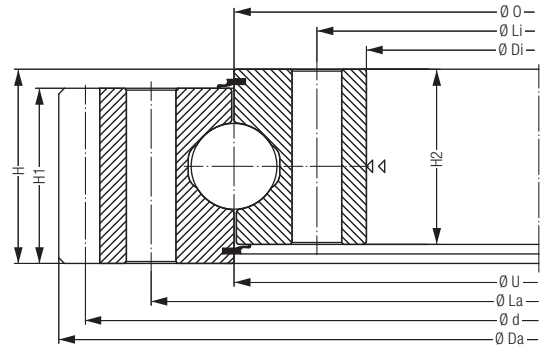
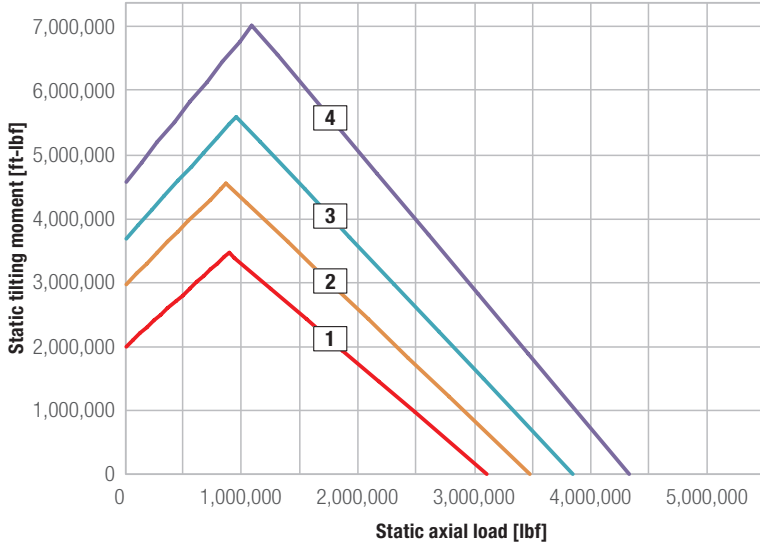

- 1 KUD01900-050VA15-900-000
- 2 KUD02130-050VA15-900-000
- 3 KUD02355-050VA15-900-000
- 4 KUD02645-050VA15-900-000

Bearing type	Bearing data								Bolt data					Gear data						Load rating			
	Weight	Outer diameter	Inner diameter	Total height	Outer diameter Inner ring	Inner diameter Outer ring	Height Outer ring	Height Inner ring	Pitch circle diameter Outer ring	Pitch circle diameter Inner ring	Number of bores per ring	Bolt diameter	Number of grease nipples per level	Pitch circle diameter	Module (metric)	Number of teeth	Profile shift	Tip reduction	Tooth width	Tooth forces (standard)	Tooth forces (maximum)	static	dynamic
	[lbs]	[inch]	[inch]	[inch]	[inch]	[inch]	[inch]	[inch]	[inch]	[inch]		[mm]	n1	d	m	z	x*m	k*m	b	[lbf]	[lbf]	C <sub>stat</sub>	C <sub>dyn</sub>
1	1,804.0	84.22	68.07	4.29	74.80	74.80	3.94	3.90	78.94	70.67	36	30	9	82.68	14	150	0.276	-0.055	3.937	28,887.9	57,775.9	3,099,441	268,197
2	2,048.2	93.73	77.13	4.29	83.86	83.86	3.94	3.90	87.99	79.72	48	30	8	91.97	16	146	0.315	-0.063	3.937	33,002.0	66,003.9	3,468,802	279,662
3	2,252.8	102.55	85.98	4.29	92.72	92.72	3.94	3.90	96.85	88.58	54	30	9	100.79	16	160	0.315	-0.063	3.937	33,002.0	66,003.9	3,838,388	290,228
4	2,512.4	113.85	97.40	4.29	104.13	104.13	3.94	3.90	108.27	100.00	60	30	12	112.13	16	178	0.315	-0.063	3.937	33,002.0	66,003.9	4,321,502	303,492

## Internal gear KUD\_25\_VJ

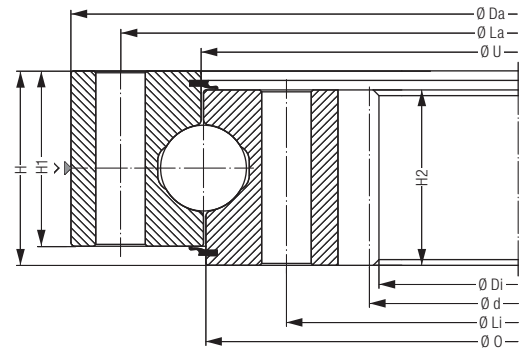
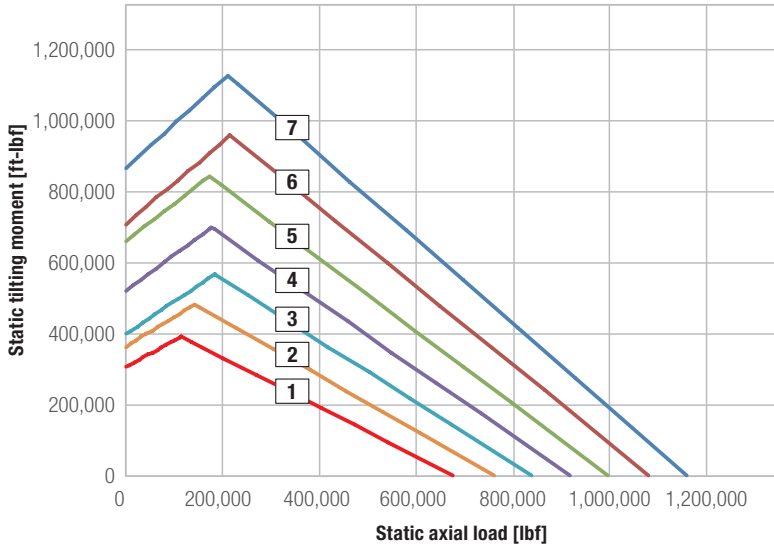

- 1 KUD00855-025VJ15-900-000
- 2 KUD00955-025VJ15-900-000
- 3 KUD01055-025VJ15-900-000
- 4 KUD01155-025VJ15-900-000
- 5 KUD01255-025VJ15-900-000
- 6 KUD01355-025VJ15-900-000
- 7 KUD01455-025VJ15-900-000

Bearing type	Bearing data								Bolt data					Gear data							Load rating		
	Weight	Outer diameter	Inner diameter	Total height	Outer diameter Inner ring	Inner diameter Outer ring	Height Outer ring	Height Inner ring	Pitch circle diameter Outer ring	Pitch circle diameter Inner ring	Number of bores per ring	Bolt diameter	Number of grease nipples per level	Pitch circle diameter	Module (metric)	Number of teeth	Profile shift	Tip reduction	Tooth width	Tooth forces (standard)	Tooth forces (maximum)	static	dynamic
	[lbs]	Da [inch]	Di [inch]	H [inch]	O [inch]	U [inch]	H1 [inch]	H2 [inch]	La [inch]	Li [inch]	n	M	n1	d [inch]	m [mm]	z	x*m	k*m	b [inch]	[lbf]	[lbf]	C <sub>stat</sub> [lbf]	C <sub>dyn</sub> [lbf]
1	292.6	37.60	27.95	3.15	33.66	33.66	2.80	2.13	36.02	31.26	28	20	4	28.74	10	-73	-	-	2.80	8646.2	17,292.3	675,326	95,094
2	330.0	41.54	31.89	3.15	37.60	37.60	2.80	2.13	39.96	35.20	30	20	6	32.68	10	-83	-	-	2.80	8646.2	17,292.3	760,529	99,590
3	365.2	45.47	35.83	3.15	41.54	41.54	2.80	2.13	43.90	39.13	30	20	6	36.61	10	-93	-	-	2.80	8646.2	17,292.3	838,762	103,187
4	402.6	49.41	39.76	3.15	45.47	45.47	2.80	2.13	47.83	43.07	36	20	6	40.55	10	-103	-	-	2.80	8646.2	172,92.3	916,996	106,559
5	435.6	53.35	43.70	3.15	49.41	49.41	2.80	2.13	51.77	47.01	42	20	6	44.49	10	-113	-	-	2.80	8646.2	17,292.3	995,229	109,932
6	473.0	57.28	47.64	3.15	53.35	53.35	2.80	2.13	55.71	50.94	42	20	6	48.43	10	-123	-	-	2.80	8646.2	17,292.3	1,080,432	113,529
7	503.8	61.22	51.57	3.15	57.28	57.28	2.80	2.13	59.65	54.88	48	20	6	52.36	10	-133	-	-	2.80	8646.2	17,292.3	1,158,665	116,451

## Internal gear KUD\_25\_VJ

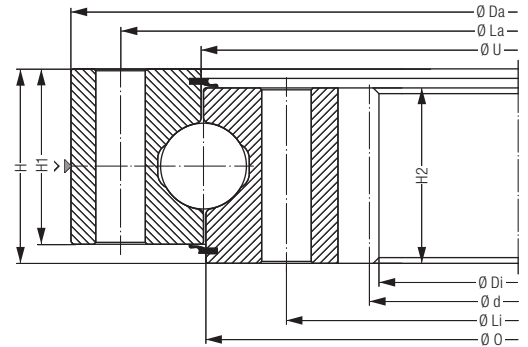
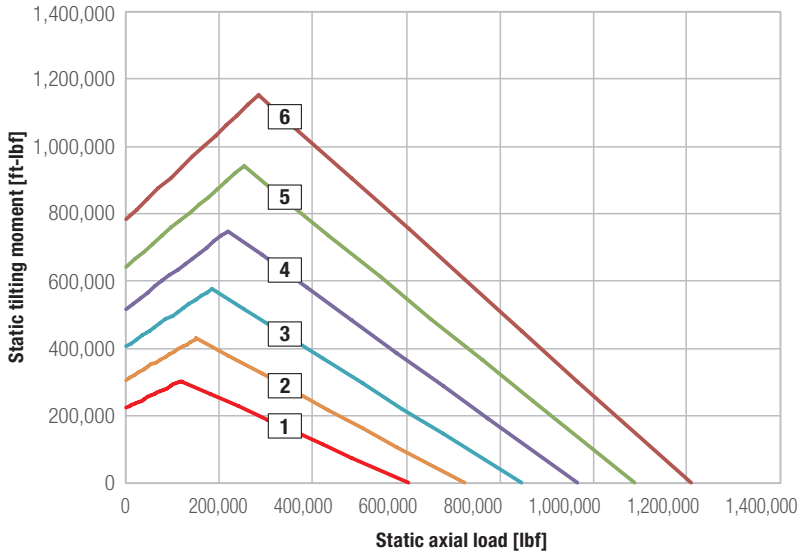

- 1 KUD00762-025VJ15-900-000
- 2 KUD00914-025VJ15-900-000
- 3 KUD01067-025VJ15-900-000
- 4 KUD01219-025VJ15-900-000
- 5 KUD01372-025VJ15-900-000
- 6 KUD01524-025VJ15-900-000

Bearing type	Bearing data								Bolt data					Gear data							Load rating		
	Weight	Outer diameter	Inner diameter	Total height	Outer diameter Inner ring	Inner diameter Outer ring	Height Outer ring	Height Inner ring	Pitch circle diameter Outer ring	Pitch circle diameter Inner ring	Number of bores per ring	Bolt diameter	Number of grease nipples per level	Pitch circle diameter	Diametral Pitch	Number of teeth	Profile shift	Tip reduction	Tooth width	Tooth forces (standard)	Tooth forces (maximum)	static	dynamic
	[lbs]	Da [inch]	Di [inch]	H [inch]	O [inch]	U [inch]	H1 [inch]	H2 [inch]	La [inch]	Li [inch]	n	M [inch]	n1	d [inch]	Pd [mm]	z	x*m [inch]	k*m [inch]	b [inch]	[lbf]	[lbf]	C <sub>stat</sub> [lbf]	C <sub>dyn</sub> [lbf]
1	411	36.00	24.16	3.50	30.00	30.00	3.00	3.00	33.25	27.25	24/30	3/4" - 10 UNC	4	24.80	2.5	-62	-	-	3.00	10,891.5	21,783.0	618,449	92,846
2	517	42.00	30.16	3.50	35.98	35.98	3.00	3.00	39.25	33.25	28/32	3/4" - 10 UNC	6	30.80	2.5	-77	-	-	3.00	10,597.5	21,195.0	746,366	99,590
3	580	48.00	36.16	3.50	42.01	42.01	3.00	3.00	45.25	39.25	32/36	3/4" - 10 UNC	6	36.80	2.5	-92	-	-	3.00	10,409.5	20,819.0	874,282	105,885
4	689	54.00	42.16	3.50	47.99	47.99	3.00	3.00	51.25	45.25	36/40	3/4" - 10 UNC	6	42.80	2.5	-107	-	-	3.00	10,274.0	20,548.0	995,229	110,831
5	775	60.00	48.16	3.50	54.02	54.02	3.00	3.00	57.25	51.25	40/44	3/4" - 10 UNC	6	48.80	2.5	-122	-	-	3.00	10,172.0	20,344.0	1,123,145	116,001
6	842	66.00	54.16	3.50	60.00	60.00	3.00	3.00	63.25	57.25	44/48	3/4" - 10 UNC	6	54.80	2.5	-137	-	-	3.00	10,092.5	20,185.0	1,243,868	120,273

## Internal gear KUD\_30\_VJ

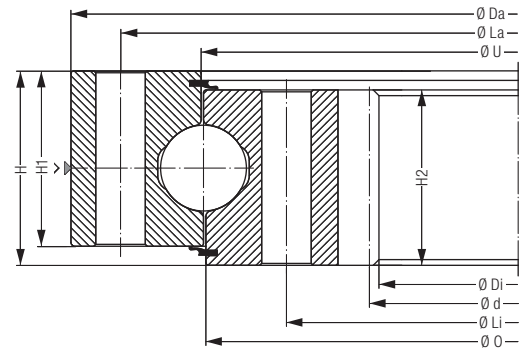
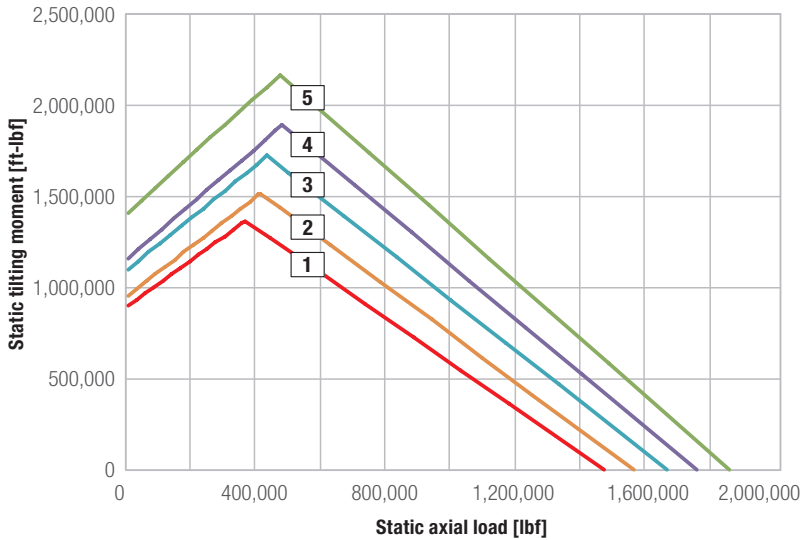

- 1 KUD01500-030VJ15-900-000
- 2 KUD01600-030VJ15-900-000
- 3 KUD01700-030VJ15-900-000
- 4 KUD01800-030VJ15-900-000
- 5 KUD01900-030VJ15-900-000

Bearing type	Bearing data								Bolt data						Gear data						Load rating		
	Weight	Outer diameter	Inner diameter	Total height	Outer diameter	Inner diameter	Height	Height	Pitch circle diameter	Pitch circle diameter	Number of bores per ring	Bolt diameter	Number of grease nipples per level	Pitch circle diameter	Module (metric)	Number of teeth	Profile shift	Tip reduction	Tooth width	Tooth forces (standard)	Tooth forces (maximum)	static	dynamic
	[lbs]	Da [inch]	Di [inch]	H [inch]	O [inch]	U [inch]	H1 [inch]	H2 [inch]	La [inch]	Li [inch]	n	M	n1	d [inch]	m [mm]	z	x*m [inch]	k*m [inch]	b [inch]			C <sub>stat</sub> [lbf]	C <sub>dyn</sub> [lbf]
1	660.0	63.31	52.54	3.31	59.06	59.06	2.83	2.83	61.57	56.54	48	20	6	52.91	12	-112	-0.24	-0.047	2.83	17,827.3	35,656.9	1,473,847	145,676
2	719.4	67.24	56.31	3.31	62.99	62.99	2.83	2.83	65.51	60.47	48	20	6	56.69	12	-120	-0.24	-0.047	2.83	17,827.3	35,656.9	1,566,019	148,824
3	739.2	71.18	60.57	3.31	66.93	66.93	2.83	2.83	69.45	64.41	52	20	7	60.94	12	-129	-0.24	-0.047	2.83	17,827.3	35,656.9	1,668,307	152,420
4	798.6	75.12	64.35	3.31	70.87	70.87	2.83	2.83	73.39	68.35	52	20	7	64.72	12	-137	-0.24	-0.047	2.83	17,827.3	35,656.9	1,760,479	155,343
5	851.4	79.06	68.13	3.31	74.80	74.80	2.83	2.83	77.32	72.28	60	20	8	68.50	12	-145	-0.24	-0.047	2.83	17,827.3	35,656.9	1,862,767	158,715

## Internal gear KUD\_35\_VJ

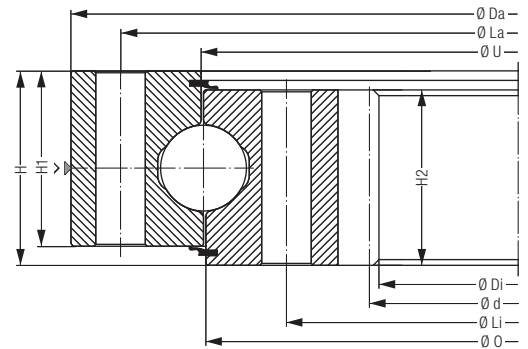
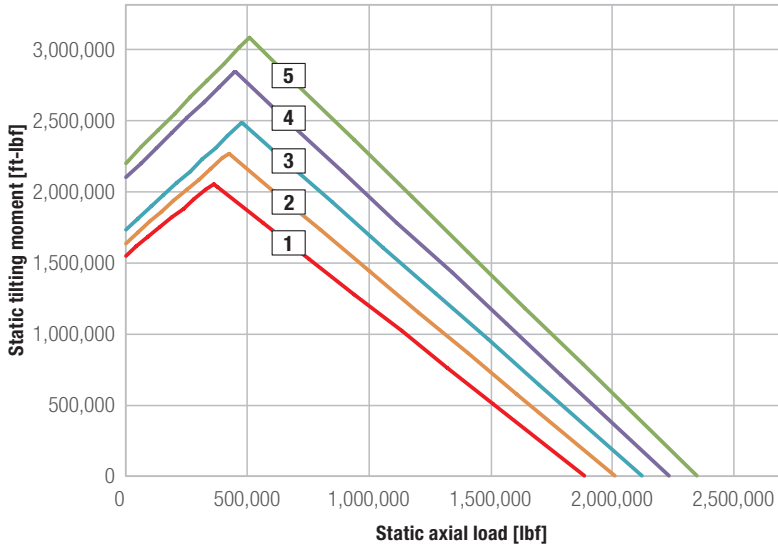

- 1 KUD01650-035VJ15-900-000
- 2 KUD01750-035VJ15-900-000
- 3 KUD01850-035VJ15-900-000
- 4 KUD01950-035VJ15-900-000
- 5 KUD02050-035VJ15-900-000

Bearing type	Bearing data								Bolt data						Gear data						Load rating		
	Weight	Outer diameter	Inner diameter	Total height	Outer diameter	Inner diameter	Height	Height	Pitch circle diameter	Pitch circle diameter	Number of bores per ring	Bolt diameter	Number of grease nipples per level	Pitch circle diameter	Module (metric)	Number of teeth	Profile shift	Tip reduction	Tooth width	Tooth forces (standard)	Tooth forces (maximum)	static	dynamic
	[lbs]	Da [inch]	Di [inch]	H [inch]	O [inch]	U [inch]	H1 [inch]	H2 [inch]	La [inch]	Li [inch]	n	M [mm]	n1	d [inch]	m [mm]	z	x*m [inch]	k*m [inch]	b [inch]	[lbf]	[lbf]	C <sub>stat</sub> [lbf]	C <sub>dyn</sub> [lbf]
1	935.0	69.96	57.73	3.70	64.96	64.96	3.23	3.23	67.91	62.01	52	24	7	58.11	12	-123	-0.236	-0.047	3.23	20,304.7	40,609.5	1,880,752	176,250
2	1,012.0	73.90	61.51	3.70	68.90	68.90	3.23	3.23	71.85	65.94	52	24	7	61.89	12	-131	-0.236	-0.047	3.23	20,304.7	40,609.5	2,006,195	180,746
3	1,045.0	77.83	65.76	3.70	72.83	72.83	3.23	3.23	75.79	69.88	52	24	7	66.14	12	-140	-0.236	-0.047	3.23	20,304.7	40,609.5	2,117,700	184,343
4	1,108.8	81.77	69.54	3.70	76.77	76.77	3.23	3.23	79.72	73.82	60	24	8	69.92	12	-148	-0.236	-0.047	3.23	20,304.7	40,609.5	2,228,981	187,715
5	1,221.0	85.71	72.87	3.70	80.71	80.71	3.23	3.23	83.66	77.76	60	24	8	73.31	14	-133	-0.276	-0.055	3.23	23,688.1	47,376.2	2,340,486	191,088

## Internal gear KUD\_40\_VJ

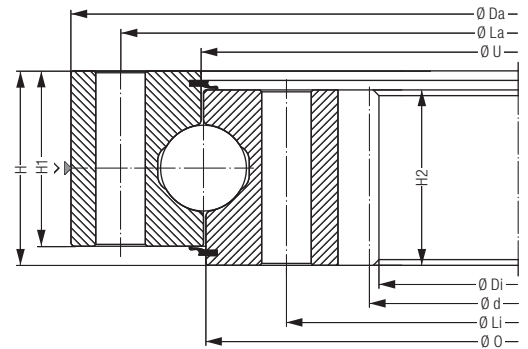
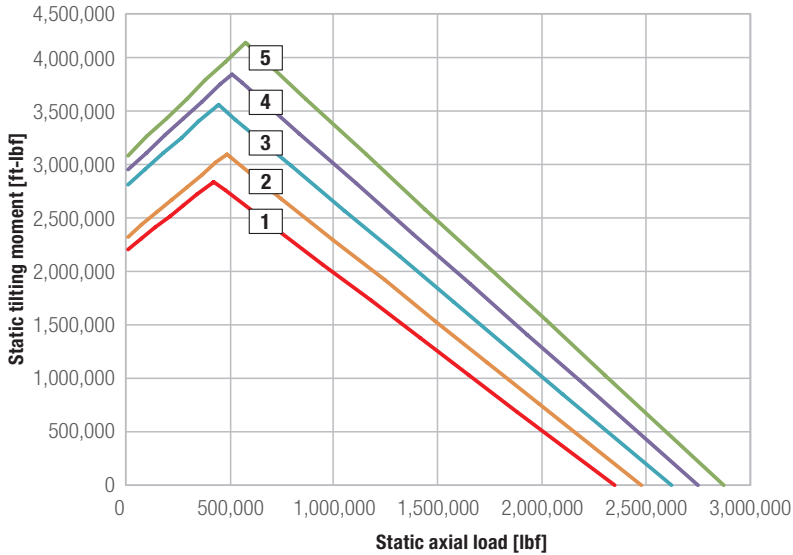

- 1 KUD01800-040VJ15-900-000
- 2 KUD01900-040VJ15-900-000
- 3 KUD02000-040VJ15-900-000
- 4 KUD02100-040VJ15-900-000
- 5 KUD02200-040VJ15-900-000

Bearing type	Bearing data								Bolt data							Gear data						Load rating	
	Weight	Outer diameter	Inner diameter	Total height	Outer diameter	Inner diameter	Height	Height	Pitch circle diameter	Pitch circle diameter	Number of bores per ring	Bolt diameter	Number of grease nipples per level	Pitch circle diameter	Module (metric)	Number of teeth	Profile shift	Tip reduction	Tooth width	Tooth forces (standard)	Tooth forces (maximum)	static	dynamic
	[lbs]	Da [inch]	Di [inch]	H [inch]	O [inch]	U [inch]	H1 [inch]	H2 [inch]	La [inch]	Li [inch]	n	M	n1	d [inch]	m [mm]	z	x*m [inch]	k*m [inch]	b [inch]	[lbf]	[lbf]	C <sub>stat</sub> [lbf]	C <sub>dyn</sub> [lbf]
1	1,278.2	76.57	62.93	4.09	70.87	70.87	3.62	3.62	74.21	67.52	52	27	7	63.31	12	-134	-0.236	-0.047	3.62	22,779.9	45,562.0	2,347,455	208,848
2	1,375.0	80.51	66.71	4.09	74.80	74.80	3.62	3.62	78.15	71.46	52	27	7	67.09	12	-142	-0.236	-0.047	3.62	22,779.9	45,562.0	2,474,697	212,894
3	1,416.8	84.45	70.66	4.09	78.74	78.74	3.62	3.62	82.09	75.39	60	27	7	71.10	14	-129	-0.276	-0.055	3.62	26,576.9	53,153.8	2,620,373	217,840
4	1,504.8	88.39	74.52	4.09	82.68	82.68	3.62	3.62	86.02	79.33	60	27	8	74.96	14	-136	-0.276	-0.055	3.62	26,576.9	53,153.8	2,747,615	221,662
5	1,595.0	92.32	78.38	4.09	86.61	86.61	3.62	3.62	89.96	83.27	60	27	8	78.82	14	-143	-0.276	-0.055	3.62	26,576.9	53,153.8	2,875,082	225,259



## Internal gear KUD\_45\_VJ

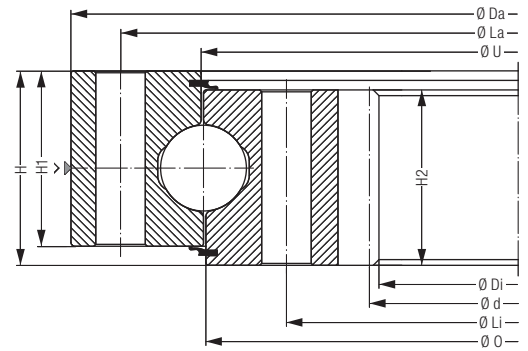
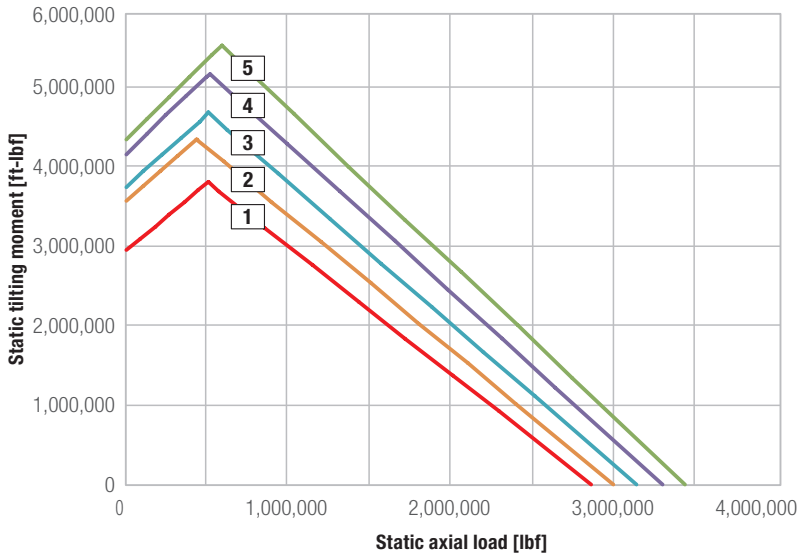

- 1 KUD01950-045VJ15-900-000
- 2 KUD02050-045VJ15-900-000
- 3 KUD02150-045VJ15-900-000
- 4 KUD02250-045VJ15-900-000
- 5 KUD02350-045VJ15-900-000

Bearing type	Bearing data								Bolt data					Gear data							Load rating		
	Weight	Outer diameter	Inner diameter	Total height	Outer diameter Inner ring	Inner diameter Outer ring	Height Outer ring	Height Inner ring	Pitch circle diameter Outer ring	Pitch circle diameter Inner ring	Number of bores per ring	Bolt diameter	Number of grease nipples per level	Pitch circle diameter	Module (metric)	Number of teeth	Profile shift	Tip reduction	Tooth width	Tooth forces (standard)	Tooth forces (maximum)	static	dynamic
	[lbs]	[inch]	[inch]	[inch]	[inch]	[inch]	[inch]	[inch]	[inch]	[inch]		[mm]		[inch]	[mm]		[inch]	[inch]	[inch]	[lbf]	[lbf]	$C_{stat}$	$C_{dyn}$
1	1,694.0	83.11	68.13	4.49	76.77	76.77	4.02	4.02	80.51	73.03	52	30	8	68.50	12	-145	-0.236	-0.047	4.02	25,257.3	50,514.6	2,878,903	243,918
2	1,786.4	87.05	71.76	4.49	80.71	80.71	4.02	4.02	84.45	76.97	60	30	8	72.20	14	-131	-0.276	-0.055	4.02	29,465.7	58,931.4	3,016,936	247,964
3	1,894.2	90.98	75.62	4.49	84.65	84.65	4.02	4.02	88.39	80.91	60	30	8	76.06	14	-138	-0.276	-0.055	4.02	29,465.7	58,931.4	3,155,194	251,786
4	1,991.0	94.92	79.48	4.49	88.58	88.58	4.02	4.02	92.32	84.84	64	30	9	79.92	14	-145	-0.276	-0.055	4.02	29,465.7	58,931.4	3,316,382	256,957
5	2,101.0	98.86	83.34	4.49	92.52	92.52	4.02	4.02	96.26	88.78	64	30	9	83.78	14	-152	-0.276	-0.055	4.02	29,465.7	58,931.4	3,454,414	260,554

## Internal gear KUD\_50\_VJ

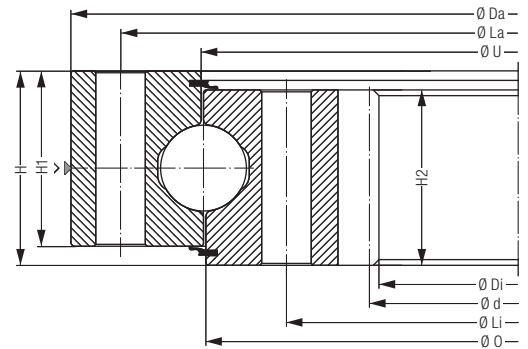
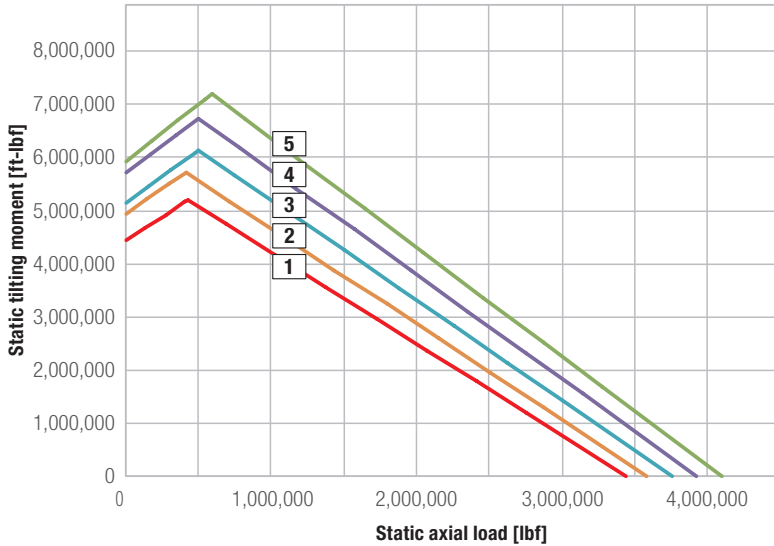

- 1 KUD02100-050VJ15-900-000
- 2 KUD02200-050VJ15-900-000
- 3 KUD02300-050VJ15-900-000
- 4 KUD02400-050VJ15-900-000
- 5 KUD02500-050VJ15-900-000

Bearing type	Bearing data								Bolt data						Gear data						Load rating		
	Weight	Outer diameter	Inner diameter	Total height	Outer diameter Inner ring	Inner diameter Outer ring	Height Outer ring	Height Inner ring	Pitch circle diameter Outer ring	Pitch circle diameter Inner ring	Number of bores per ring	Bolt diameter	Number of grease nipples per level	Pitch circle diameter	Module (metric)	Number of teeth	Profile shift	Tip reduction	Tooth width	Tooth forces (standard)	Tooth forces (maximum)	static	dynamic
	[lbs]	Da [inch]	Di [inch]	H [inch]	O [inch]	U [inch]	H1 [inch]	H2 [inch]	La [inch]	Li [inch]	n	M	n1	d [inch]	m [mm]	z	x*m	k*m	b [inch]	[lbf]	[lbf]	C <sub>stat</sub> [lbf]	C <sub>dyn</sub> [lbf]
1	2,197.8	89.61	72.87	4.88	82.68	82.68	4.41	4.41	86.77	78.58	60	33	8	73.31	14	-133	-0.276	-0.055	4.41	30,331.2	64,711.3	3,440,476	279,213
2	2,228.6	93.54	77.28	4.88	86.61	86.61	4.41	4.41	90.71	82.52	64	33	8	77.72	14	-141	-0.276	-0.055	4.41	30,331.2	64,711.3	3,582,555	282,810
3	2,354.0	97.48	81.13	4.88	90.55	90.55	4.41	4.41	94.65	86.46	64	33	8	81.57	14	-148	-0.276	-0.055	4.41	30,331.2	64,711.3	3,753,185	287,980
4	2,466.2	101.42	84.99	4.88	94.49	94.49	4.41	4.41	98.58	90.39	68	33	10	85.43	14	-155	-0.276	-0.055	4.41	30,331.2	64,711.3	3,923,590	292,926
5	2,596.0	105.35	88.85	4.88	98.43	98.43	4.41	4.41	102.52	94.33	68	33	10	89.29	14	-162	-0.276	-0.055	4.41	30,331.2	64,711.3	4,094,220	297,647

## Internal gear KUD\_50\_VJ

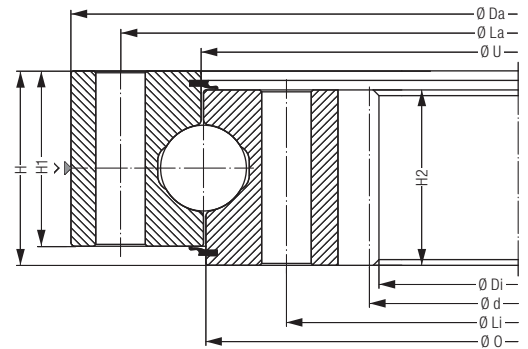
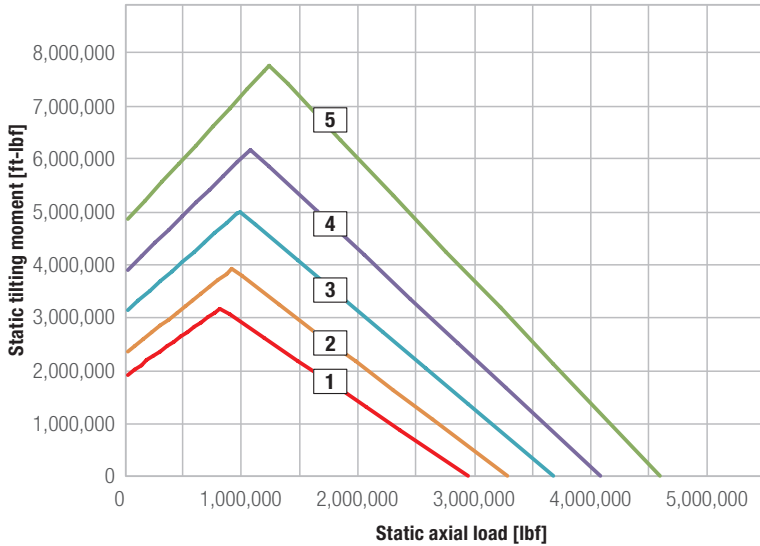

- 1 KUD01800-050VJ15-900-000
- 2 KUD02000-050VJ15-900-000
- 3 KUD02240-050VJ15-900-000
- 4 KUD02490-050VJ15-900-000
- 5 KUD02800-050VJ15-900-000

Bearing type	Bearing data								Bolt data					Gear data							Load rating		
	Weight	Outer diameter	Inner diameter	Total height	Outer diameter Inner ring	Inner diameter Outer ring	Height Outer ring	Height Inner ring	Pitch circle diameter Outer ring	Pitch circle diameter Inner ring	Number of bores per ring	Bolt diameter	Number of grease nipples per level	Pitch circle diameter	Module (metric)	Number of teeth	Profile shift	Tip reduction	Tooth width	Tooth forces (standard)	Tooth forces (maximum)	static	dynamic
	[lbs]	[inch]	[inch]	[inch]	[inch]	[inch]	[inch]	[inch]	[inch]	[inch]		[mm]		[inch]	[mm]		[inch]	[inch]	[inch]	[lbf]	[lbf]	$C_{stat}$	$C_{dyn}$
1	1,676.4	77.60	61.18	4.29	70.87	70.87	3.94	3.90	75.00	66.73	36	30	9	61.73	14	-112	-0.276	-	3.937	28,887.9	57,775.9	2,928,811	262,577
2	1,854.6	85.47	69.45	4.29	78.74	78.74	3.94	3.90	82.87	74.61	40	30	8	70.00	14	-127	-0.276	-	3.937	28,887.9	57,775.9	3,269,846	273,817
3	2,114.2	94.92	78.11	4.29	88.19	88.19	3.94	3.90	92.32	84.06	48	30	8	78.74	16	-125	-0.315	-	3.937	33,002.0	66,003.9	3,667,758	285,957
4	2,316.6	104.76	88.19	4.29	98.03	98.03	3.94	3.90	102.17	93.90	54	30	9	88.82	16	-141	-0.315	-	3.937	33,002.0	66,003.9	4,065,895	296,748
5	2,651.0	116.97	100.16	4.29	110.24	110.24	3.94	3.90	114.37	106.10	60	30	12	100.79	16	-160	-0.315	-	3.937	33,002.0	66,003.9	4,577,335	310,012

## No gearing KUD\_25\_VO

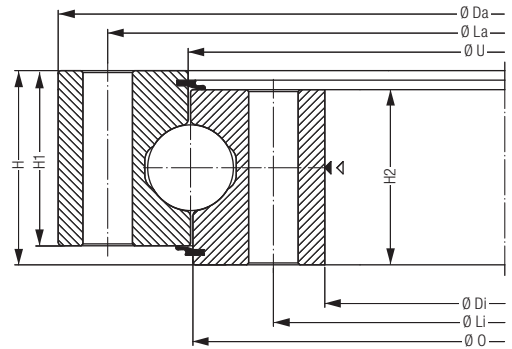
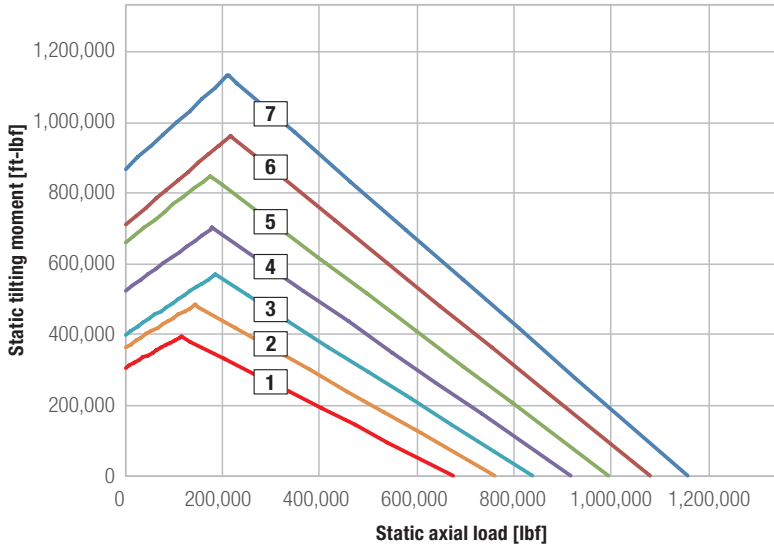

- 1 KUD00855-025V015-900-000
- 2 KUD00955-025V015-900-000
- 3 KUD01055-025V015-900-000
- 4 KUD01155-025V015-900-000
- 5 KUD01255-025V015-900-000
- 6 KUD01355-025V015-900-000
- 7 KUD01455-025V015-900-000

Bearing type	Bearing data								Bolt data					Gear data							Load rating		
	Weight	Outer diameter	Inner diameter	Total height	Outer diameter Inner ring	Inner diameter Outer ring	Height Outer ring	Height Inner ring	Pitch circle diameter Outer ring	Pitch circle diameter Inner ring	Number of bores per ring	Bolt diameter	Number of grease nipples per level	Pitch circle diameter	Module (metric)	Number of teeth	Profile shift	Tip reduction	Tooth width	Tooth forces (standard)	Tooth forces (maximum)	static	dynamic
	[lbs]	Da [inch]	Di [inch]	H [inch]	O [inch]	U [inch]	H1 [inch]	H2 [inch]	La [inch]	Li [inch]	n	M	n1	d [inch]	m [mm]	z	x*m [inch]	k*m [inch]	b [inch]			C <sub>stat</sub> [lbf]	C <sub>dyn</sub> [lbf]
1	220	37.60	29.72	2.48	33.66	33.66	2.13	2.13	36.02	31.30	28	20	4	-	-	-	-	-	-	-	-	675,326	95,094
2	248.6	41.54	33.66	2.48	37.60	37.60	2.13	2.13	39.96	35.24	30	20	6	-	-	-	-	-	-	-	-	760,529	99,590
3	272.8	45.47	37.60	2.48	41.54	41.54	2.13	2.13	43.90	39.17	30	20	6	-	-	-	-	-	-	-	-	838,762	103,187
4	305.8	49.41	41.54	2.48	45.47	45.47	2.13	2.13	47.83	43.11	36	20	6	-	-	-	-	-	-	-	-	916,996	106,559
5	325.6	53.35	45.47	2.48	49.41	49.41	2.13	2.13	51.77	47.05	42	20	6	-	-	-	-	-	-	-	-	995,229	109,932
6	354.2	57.28	49.41	2.48	53.35	53.35	2.13	2.13	55.71	50.98	42	20	6	-	-	-	-	-	-	-	-	1,080,432	113,529
7	376.2	61.22	53.35	2.48	57.28	57.28	2.13	2.13	59.65	54.92	48	20	6	-	-	-	-	-	-	-	-	1,158,665	116,451

## No gearing KUD\_25\_VO

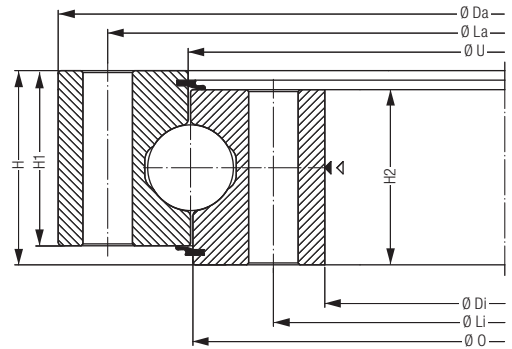
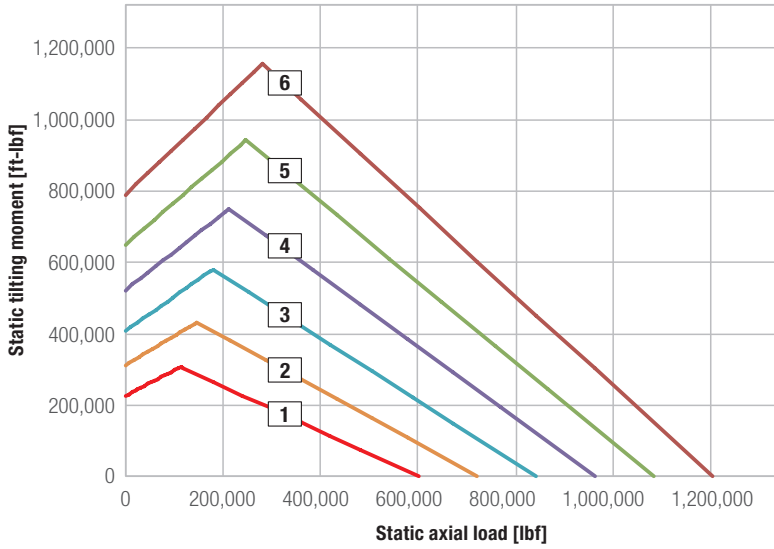

- 1 KUD00762-025V015-900-000
- 2 KUD00914-025V015-900-000
- 3 KUD01067-025V015-900-000
- 4 KUD01219-025V015-900-000
- 5 KUD01372-025V015-900-000
- 6 KUD01524-025V015-900-000

Bearing type	Bearing data								Bolt data					Gear data							Load rating			
	Weight	Outer diameter	Inner diameter	Total height	Outer diameter Inner ring	Inner diameter Outer ring	Height Outer ring	Height Inner ring	Pitch circle diameter Outer ring	Pitch circle diameter Inner ring	Number of bores per ring	Bolt diameter	Number of grease nipples per level	Pitch circle diameter	Diametral Pitch	Number of teeth	Profile shift	Tip reduction	Tooth width	Tooth forces (standard)	Tooth forces (maximum)	static	dynamic	
	[lbs]	[inch]	[inch]	[inch]	[inch]	[inch]	[inch]	[inch]	[inch]	[inch]	La/Li	[inch]	n1	d	Pd	z	x*m	k*m	b	[lbf]	[lbf]	C <sub>stat</sub>	C <sub>dyn</sub>	
1	447	36.00	24.00	3.50	30.00	30.00	3.00	3.00	33.25	26.75	24/30	3/4" - 10 UNC	4	-	-	-	-	-	-	-	-	-	618,449	92,846
2	521	42.00	30.00	3.50	36.00	36.00	3.00	3.00	39.25	32.75	28/32	3/4" - 10 UNC	6	-	-	-	-	-	-	-	-	-	746,366	99,590
3	628	48.00	36.00	3.50	42.00	42.00	3.00	3.00	45.25	38.75	32/36	3/4" - 10 UNC	6	-	-	-	-	-	-	-	-	-	874,282	105,885
4	719	54.00	42.00	3.50	48.00	48.00	3.00	3.00	51.25	44.75	36/40	3/4" - 10 UNC	6	-	-	-	-	-	-	-	-	-	995,229	110,831
5	809	60.00	48.00	3.50	54.00	54.00	3.00	3.00	57.25	50.75	40/44	3/4" - 10 UNC	6	-	-	-	-	-	-	-	-	-	1,123,145	116,001
6	865	66.00	54.00	3.50	60.00	60.00	3.00	3.00	63.25	56.75	44/48	3/4" - 10 UNC	6	-	-	-	-	-	-	-	-	-	1,243,868	120,273

## No gearing KUD\_30\_VO

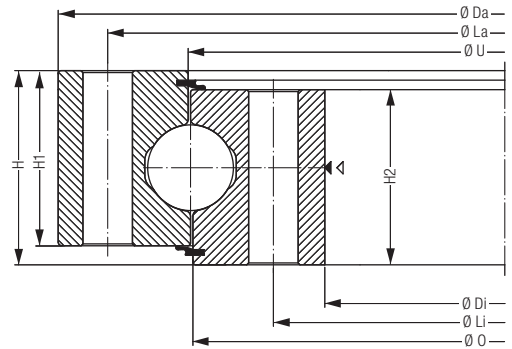
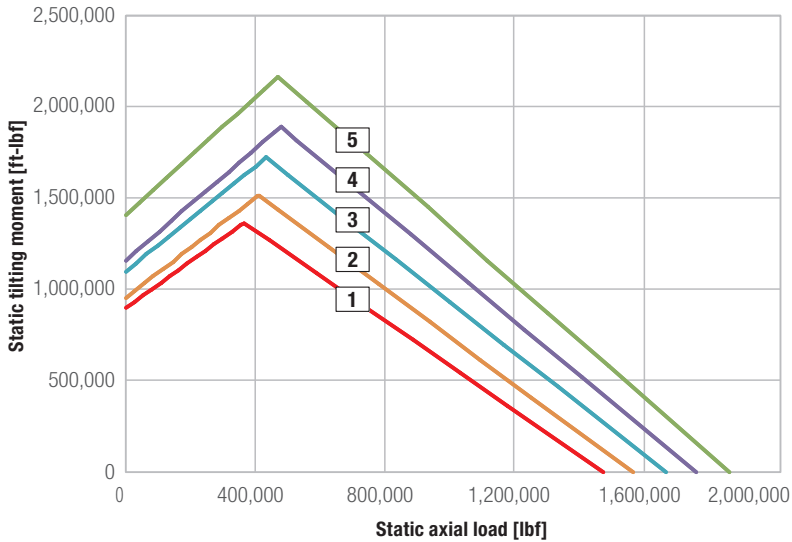

- 1 KUD01500-030V015-900-000
- 2 KUD01600-030V015-900-000
- 3 KUD01700-030V015-900-000
- 4 KUD01800-030V015-900-000
- 5 KUD01900-030V015-900-000

Bearing type	Bearing data								Bolt data						Gear data						Load rating		
	Weight	Outer diameter	Inner diameter	Total height	Outer diameter Inner ring	Inner diameter Outer ring	Height Outer ring	Height Inner ring	Pitch circle diameter Outer ring	Pitch circle diameter Inner ring	Number of bores per ring	Bolt diameter	Number of grease nipples per level	Pitch circle diameter	Module (metric)	Number of teeth	Profile shift	Tip reduction	Tooth width	Tooth forces (standard)	Tooth forces (maximum)	static	dynamic
	[lbs]	Da [inch]	Di [inch]	H [inch]	O [inch]	U [inch]	H1 [inch]	H2 [inch]	La [inch]	Li [inch]	n	M [mm]	n1	d [inch]	m [mm]	z	x*m [inch]	k*m [inch]	b [inch]			C <sub>stat</sub> [lbf]	C <sub>dyn</sub> [lbf]
1	563.2	63.31	54.80	3.31	59.06	59.06	2.83	2.83	61.57	56.54	48	20	6	-	-	-	-	-	-	-	-	1,473,847	145,676
2	602.8	67.24	58.74	3.31	62.99	62.99	2.83	2.83	65.51	60.47	48	20	6	-	-	-	-	-	-	-	-	1,566,019	148,824
3	640.2	71.18	62.68	3.31	66.93	66.93	2.83	2.83	69.45	64.41	52	20	7	-	-	-	-	-	-	-	-	1,668,307	152,420
4	679.8	75.12	66.61	3.31	70.87	70.87	2.83	2.83	73.39	68.35	52	20	7	-	-	-	-	-	-	-	-	1,760,479	155,343
5	712.8	79.06	70.55	3.31	74.80	74.80	2.83	2.83	77.32	72.28	60	20	8	-	-	-	-	-	-	-	-	1,862,767	158,715

## No gearing KUD\_35\_VO

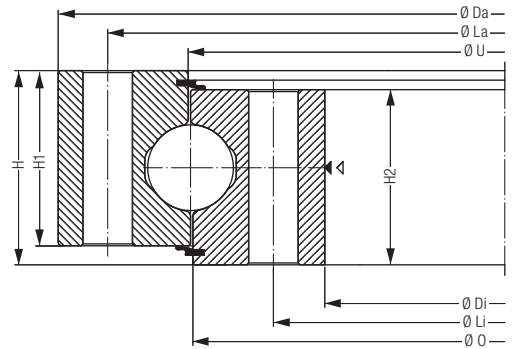
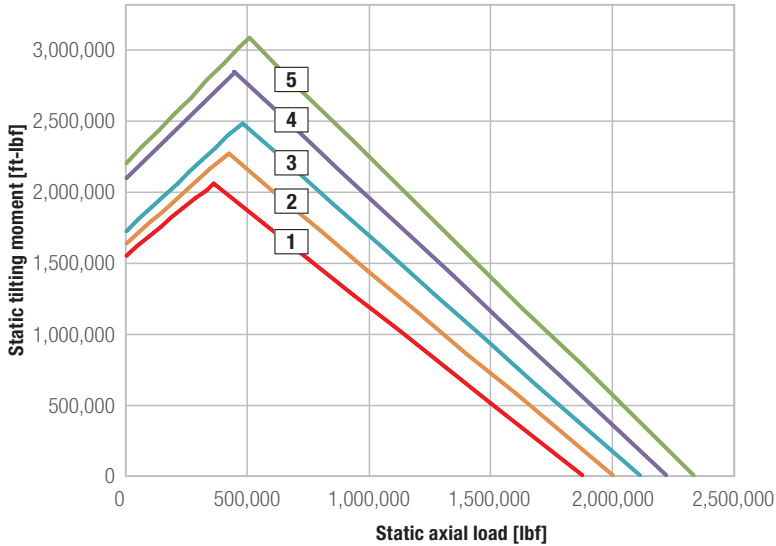

- 1 KUD01650-035V015-900-000
- 2 KUD01750-035V015-900-000
- 3 KUD01850-035V015-900-000
- 4 KUD01950-035V015-900-000
- 5 KUD02050-035V015-900-000

Bearing type	Bearing data								Bolt data					Gear data							Load rating		
	Weight	Outer diameter	Inner diameter	Total height	Outer diameter	Inner diameter	Height	Height	Pitch circle diameter	Pitch circle diameter	Number of bores per ring	Bolt diameter	Number of grease nipples per level	Pitch circle diameter	Module (metric)	Number of teeth	Profile shift	Tip reduction	Tooth width	Tooth forces (standard)	Tooth forces (maximum)	static	dynamic
	[lbs]	Da [inch]	Di [inch]	H [inch]	O [inch]	U [inch]	H1 [inch]	H2 [inch]	La [inch]	Li [inch]	n	M	n1	d [inch]	m [mm]	z	x*m [inch]	k*m [inch]	b [inch]			C <sub>stat</sub> [lbf]	C <sub>dyn</sub> [lbf]
1	818.4	69.96	59.96	3.70	64.96	64.96	3.23	3.23	67.91	62.01	52	24	7	-	-	-	-	-	-	-	-	1,880,752	176,250
2	873.4	73.90	63.90	3.70	68.90	68.90	3.23	3.23	71.85	65.94	52	24	7	-	-	-	-	-	-	-	-	2,006,195	180,746
3	926.2	77.83	67.83	3.70	72.83	72.83	3.23	3.23	75.79	69.88	52	24	7	-	-	-	-	-	-	-	-	2,117,700	184,343
4	970.2	81.77	71.77	3.70	76.77	76.77	3.23	3.23	79.72	73.82	60	24	8	-	-	-	-	-	-	-	-	2,228,981	187,715
5	1,023.0	85.71	75.71	3.70	80.71	80.71	3.23	3.23	83.66	77.76	60	24	8	-	-	-	-	-	-	-	-	2,340,486	191,088

## No gearing KUD\_40\_VO

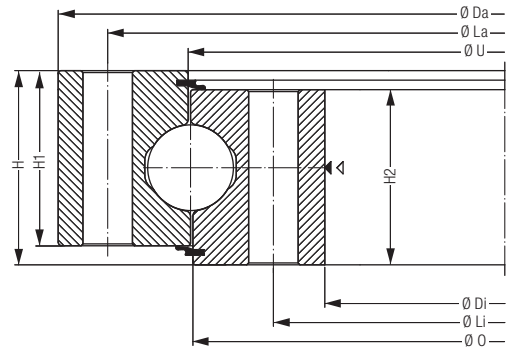
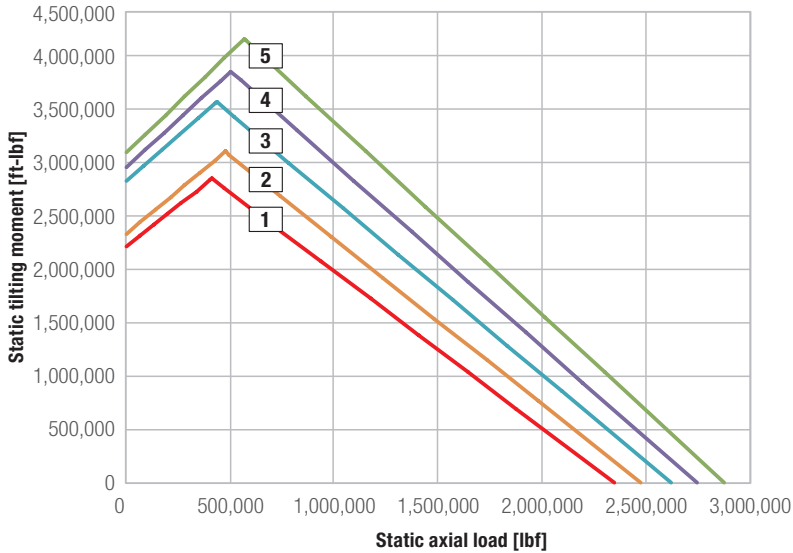

- 1 KUD01800-040V015-900-000
- 2 KUD01900-040V015-900-000
- 3 KUD02000-040V015-900-000
- 4 KUD02100-040V015-900-000
- 5 KUD02200-040V015-900-000

Bearing type	Bearing data								Bolt data						Gear data						Load rating		
	Weight	Outer diameter	Inner diameter	Total height	Outer diameter	Inner diameter	Height	Height	Pitch circle diameter	Pitch circle diameter	Number of bores per ring	Bolt diameter	Number of grease nipples per level	Pitch circle diameter	Module (metric)	Number of teeth	Profile shift	Tip reduction	Tooth width	Tooth forces (standard)	Tooth forces (maximum)	static	dynamic
	[lbs]	Da [inch]	Di [inch]	H [inch]	O [inch]	U [inch]	H1 [inch]	H2 [inch]	La [inch]	Li [inch]	n	M	n1	d [inch]	m [mm]	z	x*m [inch]	k*m [inch]	b [inch]			C <sub>stat</sub> [lbf]	C <sub>dyn</sub> [lbf]
1	1,135.2	76.57	65.16	4.09	70.87	70.87	3.62	3.62	74.21	67.52	52	27	7	-	-	-	-	-	-	-	-	2,347,455	208,848
2	1,205.6	80.51	69.09	4.09	74.80	74.80	3.62	3.62	78.15	71.46	52	27	7	-	-	-	-	-	-	-	-	2,474,697	212,894
3	1,256.2	84.45	73.03	4.09	78.74	78.74	3.62	3.62	82.09	75.39	60	27	7	-	-	-	-	-	-	-	-	2,620,373	217,840
4	1,326.6	88.39	76.97	4.09	82.68	82.68	3.62	3.62	86.02	79.33	60	27	8	-	-	-	-	-	-	-	-	2,747,615	221,662
5	1,397.0	92.32	80.91	4.09	86.61	86.61	3.62	3.62	89.96	83.27	60	27	8	-	-	-	-	-	-	-	-	2,875,082	225,259



### No gearing KUD\_45\_VO

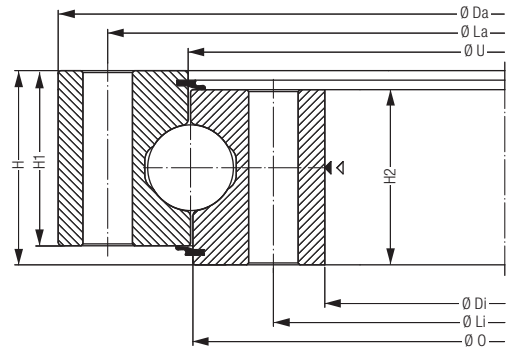
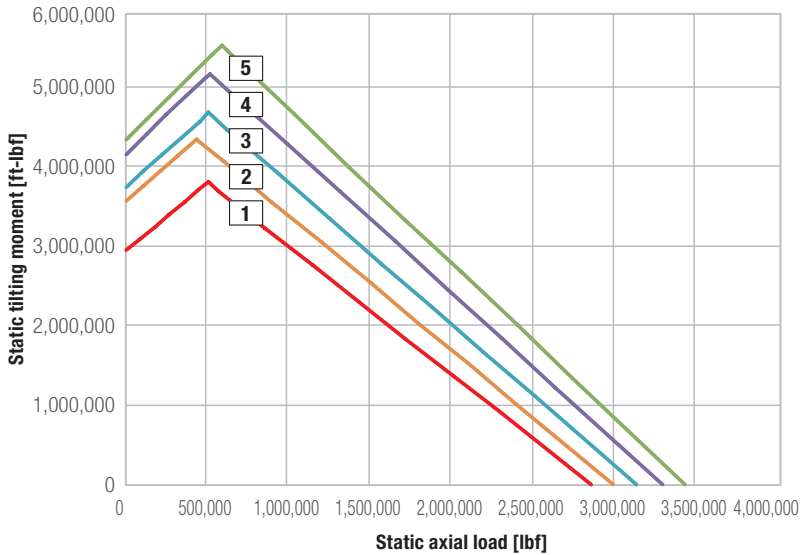

- 1 KUD01950-045V015-900-000
- 2 KUD02050-045V015-900-000
- 3 KUD02150-045V015-900-000
- 4 KUD02250-045V015-900-000
- 5 KUD02350-045V015-900-000

Bearing type	Bearing data								Bolt data					Gear data							Load rating		
	Weight	Outer diameter	Inner diameter	Total height	Outer diameter	Inner diameter	Height	Height	Pitch circle diameter	Pitch circle diameter	Number of bores per ring	Bolt diameter	Number of grease nipples per level	Pitch circle diameter	Module (metric)	Number of teeth	Profile shift	Tip reduction	Tooth width	Tooth forces (standard)	Tooth forces (maximum)	static	dynamic
	[lbs]	Da [inch]	Di [inch]	H [inch]	O [inch]	U [inch]	H1 [inch]	H2 [inch]	La [inch]	Li [inch]	n	M	n1	d [inch]	m [mm]	z	x*m [inch]	k*m [inch]	b [inch]			C <sub>stat</sub> [lbf]	C <sub>dyn</sub> [lbf]
1	1,513.6	83.11	70.43	4.49	76.77	76.77	4.02	4.02	80.51	73.03	52	30	8	-	-	-	-	-	-	-	-	2,878,903	243,918
2	1,575.2	87.05	74.37	4.49	80.71	80.71	4.02	4.02	84.45	76.97	60	30	8	-	-	-	-	-	-	-	-	3,016,936	247,964
3	1,661.0	90.98	78.31	4.49	84.65	84.65	4.02	4.02	88.39	80.91	60	30	8	-	-	-	-	-	-	-	-	3,155,194	251,786
4	1,733.6	94.92	82.24	4.49	88.58	88.58	4.02	4.02	92.32	84.84	64	30	9	-	-	-	-	-	-	-	-	3,316,382	256,957
5	1,819.4	98.86	86.18	4.49	92.52	92.52	4.02	4.02	96.26	88.78	64	30	9	-	-	-	-	-	-	-	-	3,454,414	260,554

## No gearing KUD\_50\_VO

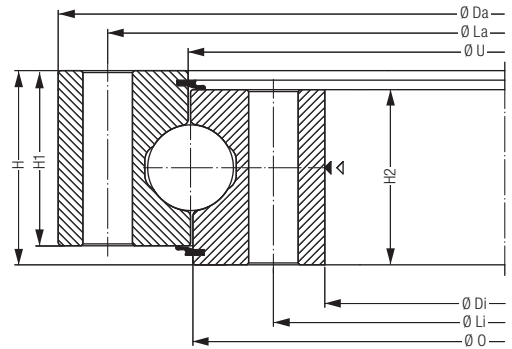
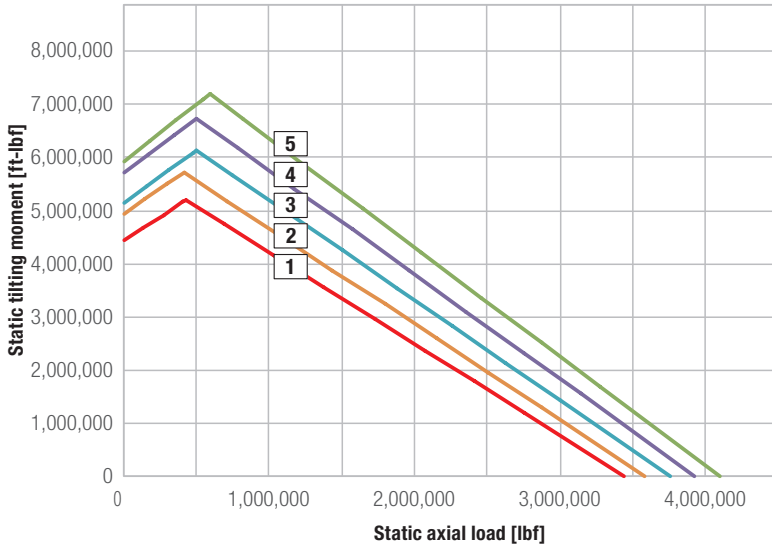

- 1 KUD02100-050V015-900-000
- 2 KUD02200-050V015-900-000
- 3 KUD02300-050V015-900-000
- 4 KUD02400-050V015-900-000
- 5 KUD02500-050V015-900-000

Bearing type	Bearing data								Bolt data					Gear data							Load rating		
	Weight	Outer diameter	Inner diameter	Total height	Outer diameter	Inner diameter	Height	Height	Pitch circle diameter	Pitch circle diameter	Number of bores per ring	Bolt diameter	Number of grease nipples per level	Pitch circle diameter	Module (metric)	Number of teeth	Profile shift	Tip reduction	Tooth width	Tooth forces (standard)	Tooth forces (maximum)	static	dynamic
	[lbs]	Da [inch]	Di [inch]	H [inch]	O [inch]	U [inch]	H1 [inch]	H2 [inch]	La [inch]	Li [inch]	n	M	n1	d [inch]	m [mm]	z	x*m [inch]	k*m [inch]	b [inch]			C <sub>stat</sub> [lbf]	C <sub>dyn</sub> [lbf]
1	1,920.6	89.61	75.75	4.88	82.68	82.68	4.41	4.41	86.77	78.58	60	33	8	-	-	-	-	-	-	-	-	3,440,476	279,213
2	2,008.6	93.54	79.69	4.88	86.61	86.61	4.41	4.41	90.71	82.52	64	33	8	-	-	-	-	-	-	-	-	3,582,555	282,810
3	2,112.0	97.48	83.62	4.88	90.55	90.55	4.41	4.41	94.65	86.46	64	33	8	-	-	-	-	-	-	-	-	3,753,185	287,980
4	2,197.8	101.42	87.56	4.88	94.49	94.49	4.41	4.41	98.58	90.39	68	33	10	-	-	-	-	-	-	-	-	3,923,590	292,926
5	2,301.2	105.35	91.50	4.88	98.43	98.43	4.41	4.41	102.52	94.33	68	33	10	-	-	-	-	-	-	-	-	4,094,220	297,647





# Technical data

## KUD\_Z Double-row ball bearings



KUD\_Z

**KUD\_ZA**

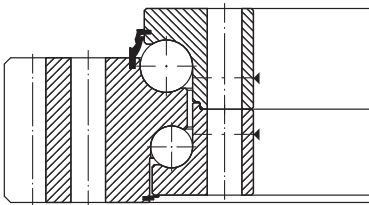

**KUD\_ZJ**

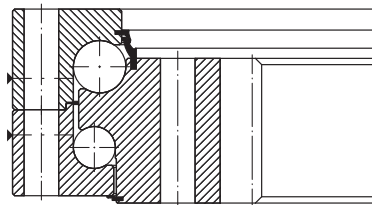

**KUD\_ZO**

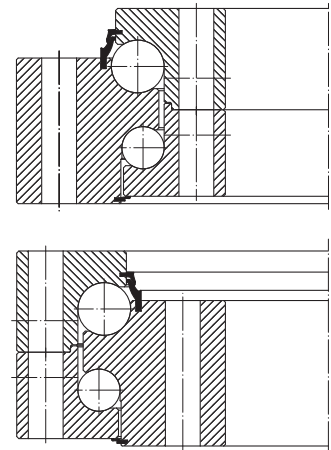

## External gear KUD\_30\_ZA

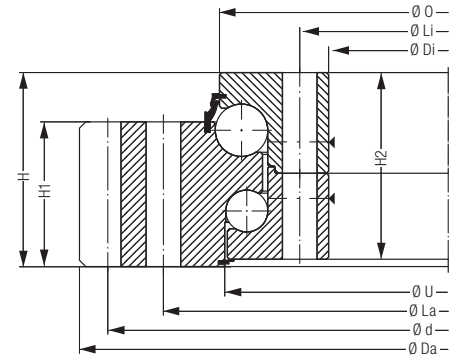
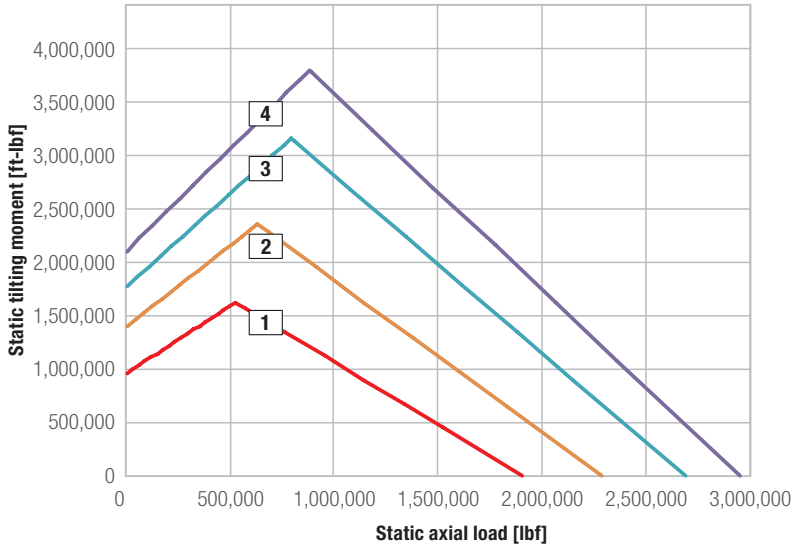

- 1 KUD01440-030ZA15-900-000
- 2 KUD01734-030ZA15-900-000
- 3 KUD02031-030ZA15-900-000
- 4 KUD02235-030ZA15-900-000

Bearing type	Bearing data								Bolt data					Gear data							Load rating		
	Weight	Outer diameter	Inner diameter	Total height	Outer diameter Inner ring	Inner diameter Outer ring	Height Outer ring	Height Inner ring	Pitch circle diameter Outer ring	Pitch circle diameter Inner ring	Number of bores per ring	Bolt diameter	Number of grease nipples per level	Pitch circle diameter	Module (metric)	Number of teeth	Profile shift	Tip reduction	Tooth width	Tooth forces (standard)	Tooth forces (maximum)	static	dynamic
	[lbs]	Da [inch]	Di [inch]	H [inch]	O [inch]	U [inch]	H1 [inch]	H2 [inch]	La [inch]	Li [inch]	n	M [mm]	n1	d [inch]	m [mm]	z	x*m [inch]	k*m [inch]	b [inch]	[lbf]	[lbf]	C <sub>stat</sub> [lbf]	C <sub>dyn</sub> [lbf]
1	1,144.0	65.10	51.97	4.72	57.83	57.48	3.58	4.49	60.83	53.74	36	24	3	63.78	12	135	0.24	-0.05	3.58	22,526	45,052	1,903,008	174,901
2	1,399.2	76.91	63.58	4.72	69.41	69.17	3.58	4.49	72.64	65.35	44	24	3	75.59	12	160	0.24	-0.05	3.58	22,526	45,052	2,289,005	187,041
3	1,661.0	88.72	75.20	4.72	81.10	80.87	3.58	4.49	84.25	76.97	48	24	4	87.40	12	185	0.24	-0.05	3.58	22,526	45,052	2,688,715	198,731
4	1,819.4	96.76	83.27	4.72	89.13	88.90	3.58	4.49	92.32	85.04	52	24	4	95.43	12	202	0.24	-0.05	3.58	22,526	45,052	2,950,617	205,475

## External gear KUD\_35\_ZA

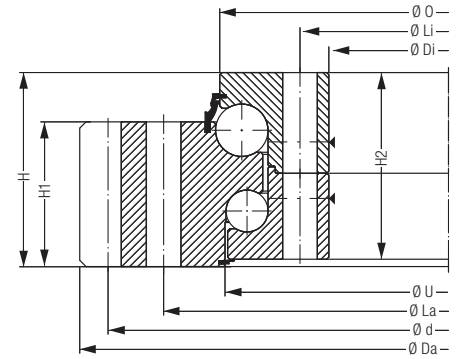
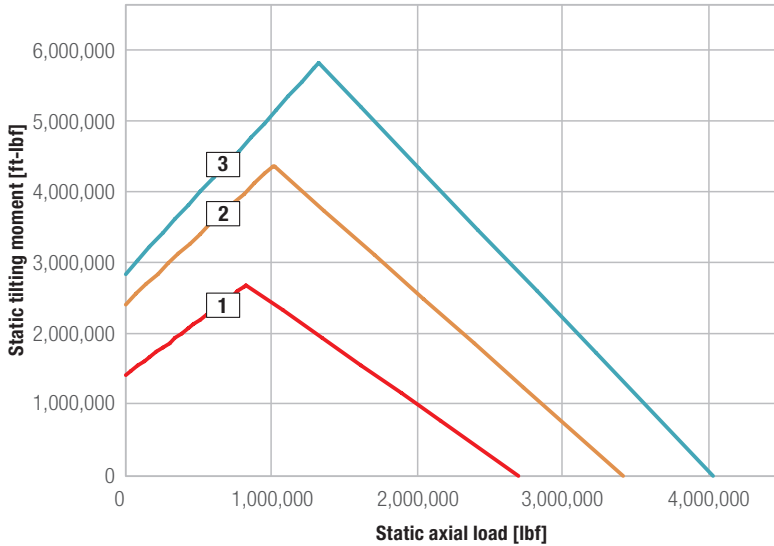

- 1 — KUD01750-035ZA15-900-000
- 2 — KUD02220-035ZA15-900-000
- 3 — KUD02620-035ZA15-900-000

Bearing type	Bearing data								Bolt data					Gear data							Load rating		
	Weight	Outer diameter	Inner diameter	Total height	Outer diameter Inner ring	Inner diameter Outer ring	Height Outer ring	Height Inner ring	Pitch circle diameter Outer ring	Pitch circle diameter Inner ring	Number of bores per ring	Bolt diameter	Number of grease nipples per level	Pitch circle diameter	Module (metric)	Number of teeth	Profile shift	Tip reduction	Tooth width	Tooth forces (standard)	Tooth forces (maximum)	static	dynamic
	[lbs]	Da [inch]	Di [inch]	H [inch]	O [inch]	U [inch]	H1 [inch]	H2 [inch]	La [inch]	Li [inch]	n	M [mm]	n1	d [inch]	m [mm]	z	x*m [inch]	k*m [inch]	b [inch]	[lbf]	[lbf]	C <sub>stat</sub> [lbf]	C <sub>dyn</sub> [lbf]
1	1,735.8	78.16	63.78	5.43	70.24	70.04	4.09	5.20	73.23	65.75	44	24	3	76.61	14	139	0.28	-0.06	4.09	30,034	60,069	2,702,653	220,538
2	2,241.8	96.90	82.28	5.43	88.74	88.54	4.09	5.20	91.93	84.06	60	24	4	95.35	14	173	0.28	-0.06	4.09	30,034	60,069	3,415,747	240,096
3	2,736.8	113.26	98.03	5.43	104.49	104.29	4.09	5.20	107.68	100.00	60	24	6	111.50	16	177	0.31	-0.06	4.09	34,328	68,657	4,035,096	255,383

## External gear KUD\_40\_ZA

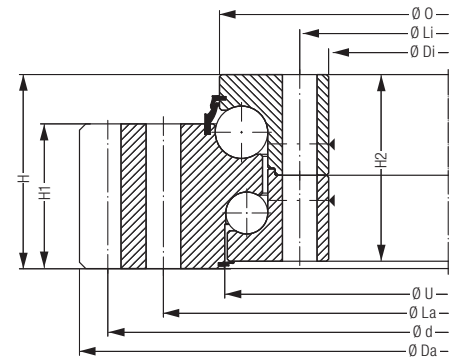
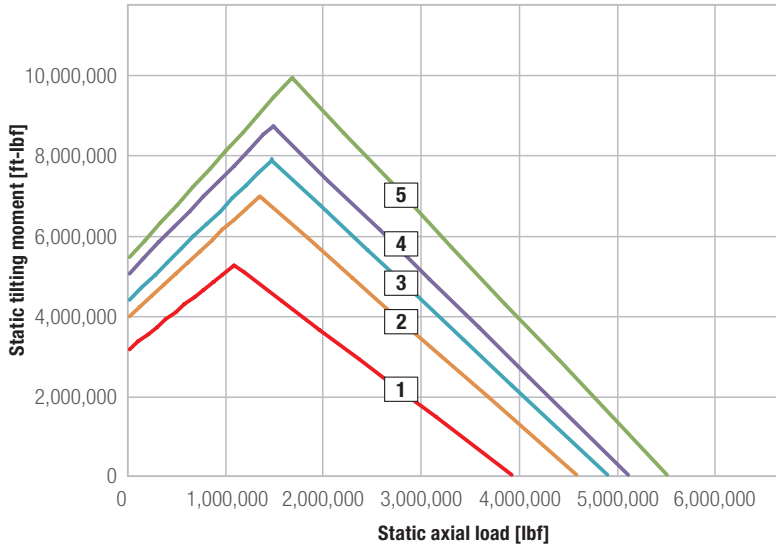

- 1 KUD02240-040ZA15-900-000
- 2 KUD02619-040ZA15-900-000
- 3 KUD02795-040ZA15-900-000
- 4 KUD02915-040ZA15-900-000
- 5 KUD03150-040ZA15-900-000

Bearing type	Bearing data								Bolt data					Gear data							Load rating		
	Weight	Outer diameter	Inner diameter	Total height	Outer diameter Inner ring	Inner diameter Outer ring	Height Outer ring	Height Inner ring	Pitch circle diameter Outer ring	Pitch circle diameter Inner ring	Number of bores per ring	Bolt diameter	Number of grease nipples per level	Pitch circle diameter	Module (metric)	Number of teeth	Profile shift	Tip reduction	Tooth width	Tooth forces (standard)	Tooth forces (maximum)	static	dynamic
	[lbs]	Da [inch]	Di [inch]	H [inch]	O [inch]	U [inch]	H1 [inch]	H2 [inch]	La [inch]	Li [inch]	n	M [mm]	n1	d [inch]	m [mm]	z	x*m [inch]	k*m [inch]	b [inch]	[lbf]	[lbf]	C <sub>stat</sub> [lbf]	C <sub>dyn</sub> [lbf]
1	2,895.2	99.40	82.28	6.14	89.57	89.45	4.61	5.91	93.50	84.45	48	30	4	97.64	16	155	0.31	-0.06	4.61	36,576	73,175	3,946,746	276,965
2	3,553.0	114.66	97.05	6.14	104.49	104.37	4.61	5.91	108.46	99.21	52	30	6	112.68	18	159	0.35	-0.07	4.61	41,163	82,325	4,608,359	292,926
3	3,790.6	121.89	104.13	6.14	111.42	111.30	4.61	5.91	115.35	106.30	54	30	6	119.69	20	152	0.39	-0.08	4.61	45,726	91,452	4,927,138	300,570
4	3,938.0	126.61	108.86	6.14	116.14	116.02	4.61	5.91	120.08	111.02	60	30	6	124.41	20	158	0.39	-0.08	4.61	45,726	91,452	5,147,675	305,515
5	4,331.8	136.06	118.11	6.14	125.39	125.28	4.61	5.91	129.33	120.28	60	30	6	133.86	20	170	0.39	-0.08	4.61	45,726	91,452	5,539,742	313,384



## External gear KUD\_50\_ZA

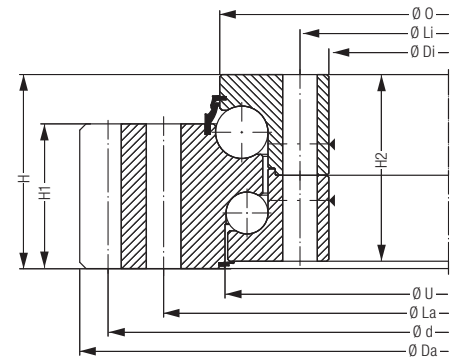
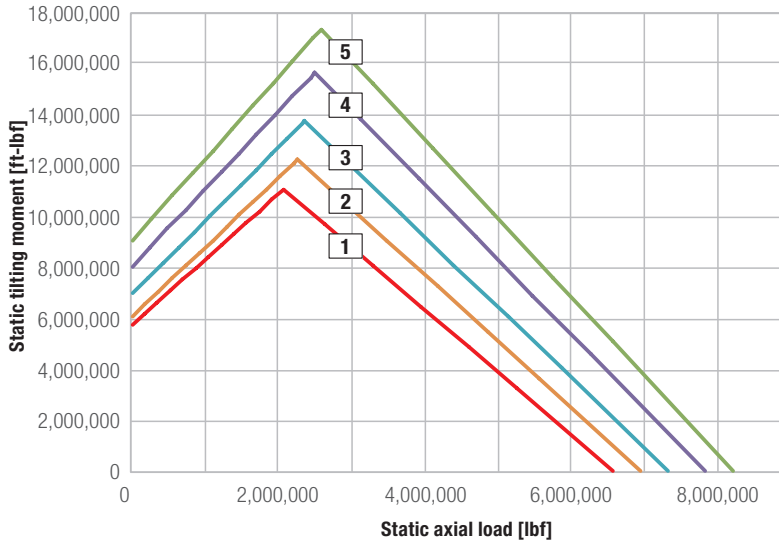

- 1 KUD02987-050ZA15-900-000
- 2 KUD03167-050ZA15-900-000
- 3 KUD03347-050ZA15-900-000
- 4 KUD03567-050ZA15-900-000
- 5 KUD03747-050ZA15-900-000

Bearing type	Bearing data								Bolt data						Gear data						Load rating		
	Weight	Outer diameter	Inner diameter	Total height	Outer diameter Inner ring	Inner diameter Outer ring	Height Outer ring	Height Inner ring	Pitch circle diameter Outer ring	Pitch circle diameter Inner ring	Number of bores per ring	Bolt diameter	Number of grease nipples per level	Pitch circle diameter	Module (metric)	Number of teeth	Profile shift	Tip reduction	Tooth width	Tooth forces (standard)	Tooth forces (maximum)	static	dynamic
	[lbs]	Da [inch]	Di [inch]	H [inch]	O [inch]	U [inch]	H1 [inch]	H2 [inch]	La [inch]	Li [inch]	n	M [mm]	n1	d [inch]	m [mm]	z	x*m [inch]	k*m [inch]	b [inch]	[lbf]	[lbf]	C <sub>stat</sub> [lbf]	C <sub>dyn</sub> [lbf]
1	5,033.6	129.54	111.02	7.28	119.25	118.86	5.43	7.01	123.23	113.39	66	30	6	127.56	18	180	0.354	-0.071	5.433	48,558.7	97,117.5	6,588,026	388,020
2	5,348.2	136.63	118.11	7.28	126.34	125.95	5.43	7.01	130.31	120.47	66	30	6	134.65	18	190	0.354	-0.071	5.433	48,558.7	97,117.5	6,970,876	395,889
3	5,645.2	143.72	137.01	7.28	133.43	133.04	5.43	7.01	137.40	127.56	72	30	6	141.73	18	200	0.354	-0.071	5.433	48,558.7	97,117.5	7,353,950	403,532
4	5,944.4	152.22	133.86	7.28	142.09	141.70	5.43	7.01	146.06	136.22	78	30	6	150.24	18	212	0.354	-0.071	5.433	48,558.7	97,117.5	7,851,677	413,424
5	8,441.4	159.31	140.94	7.28	149.17	148.78	5.43	7.01	153.15	143.31	84	30	6	157.32	18	222	0.354	-0.071	5.433	48,558.7	97,117.5	8,234,752	420,618

## Internal gear KUD\_30\_ZJ

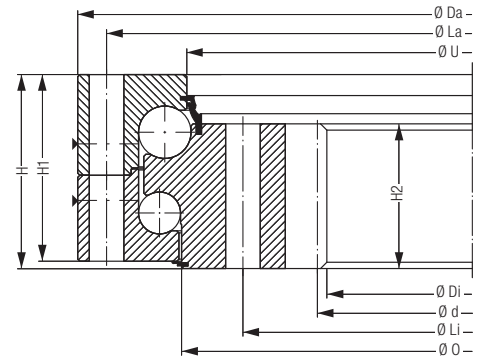
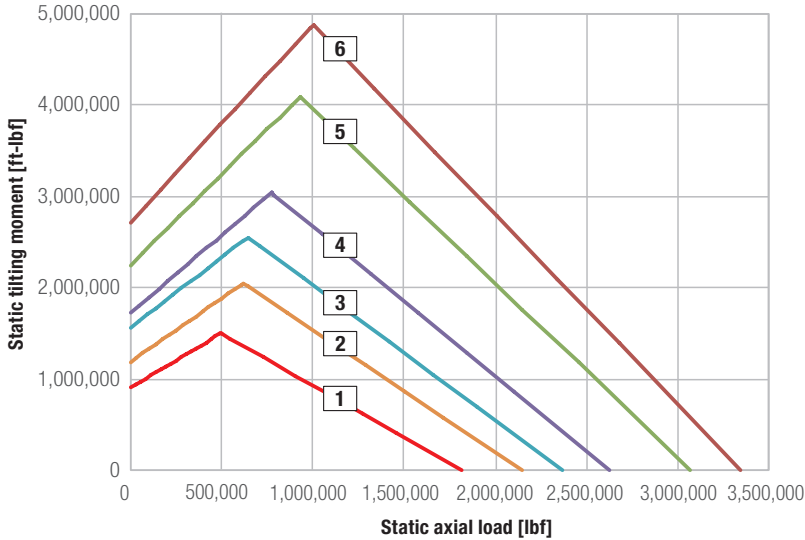

- 1 KUD01381-030ZJ15-900-000
- 2 KUD01630-030ZJ15-900-000
- 3 KUD01800-030ZJ15-900-000
- 4 KUD01995-030ZJ15-900-000
- 5 KUD02330-030ZJ15-900-000
- 6 KUD02538-030ZJ15-900-000

Bearing type	Bearing data								Bolt data					Gear data							Load rating		
	Weight	Outer diameter	Inner diameter	Total height	Outer diameter Inner ring	Inner diameter Outer ring	Height Outer ring	Height Inner ring	Pitch circle diameter Outer ring	Pitch circle diameter Inner ring	Number of bores per ring	Bolt diameter	Number of grease nipples per level	Pitch circle diameter	Module (metric)	Number of teeth	Profile shift	Tip reduction	Tooth width	Tooth forces (standard)	Tooth forces (maximum)	static	dynamic
	[lbs]	Da [inch]	Di [inch]	H [inch]	O [inch]	U [inch]	H1 [inch]	H2 [inch]	La [inch]	Li [inch]	n	M [mm]	n1	d [inch]	m [mm]	z	x*m [inch]	k*m [inch]	b [inch]	[lbf]	[lbf]	C <sub>stat</sub> [lbf]	C <sub>dyn</sub> [lbf]
1	1,042.8	59.06	45.83	4.72	53.46	53.23	4.49	3.58	57.28	50.20	36	24	3	46.30	12	-98	-0.24	-	3.58	22,526	45,052	1,820,278	171,979
2	1,227.6	68.90	55.75	4.72	63.39	63.07	4.49	3.58	67.13	60.04	40	24	4	56.22	12	-119	-0.24	-	3.58	22,526	45,052	2,150,972	182,994
3	1,414.6	75.59	61.73	4.72	69.96	69.72	4.49	3.58	73.82	66.73	48	24	3	62.28	14	-113	-0.28	-	3.58	26,280	52,560	2,371,734	189,514
4	1,575.2	83.27	69.45	4.72	77.64	77.40	4.49	3.58	81.50	74.41	48	24	4	70.00	14	-127	-0.28	-	3.58	26,280	52,560	2,633,637	196,933
5	1,845.8	96.46	82.68	4.72	90.83	90.59	4.49	3.58	94.69	87.60	54	24	4	83.23	14	-151	-0.28	-	3.58	26,280	52,560	3,074,712	208,623
6	2,118.6	104.72	90.08	4.72	99.02	98.78	4.49	3.58	102.95	95.67	60	24	6	90.71	16	-144	-0.31	-	3.58	30,034	60,069	3,350,552	215,367

## Internal gear KUD\_35\_ZJ

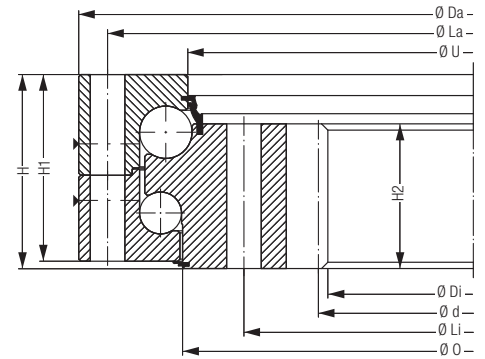
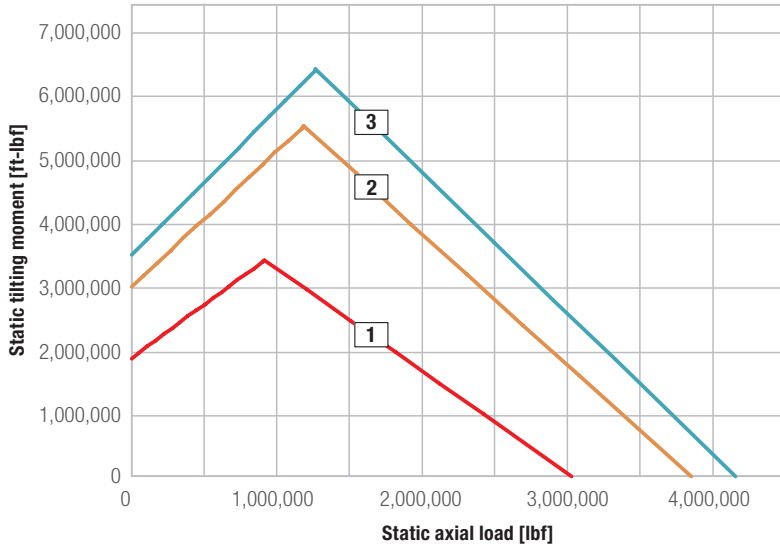

- 1 KUD01960-035ZJ15-900-000
- 2 KUD02500-035ZJ15-900-000
- 3 KUD02690-035ZJ15-900-000

Bearing type	Bearing data								Bolt data					Gear data						Load rating			
	Weight	Outer diameter	Inner diameter	Total height	Outer diameter Inner ring	Inner diameter Outer ring	Height Outer ring	Height Inner ring	Pitch circle diameter Outer ring	Pitch circle diameter Inner ring	Number of bores per ring	Bolt diameter	Number of grease nipples per level	Pitch circle diameter	Module (metric)	Number of teeth	Profile shift	Tip reduction	Tooth width	Tooth forces (standard)	Tooth forces (maximum)	static	dynamic
	[lbs]	Da [inch]	Di [inch]	H [inch]	O [inch]	U [inch]	H1 [inch]	H2 [inch]	La [inch]	Li [inch]	n	M [mm]	n1	d [inch]	m [mm]	z	x*m [inch]	k*m [inch]	b [inch]	[lbf]	[lbf]	C <sub>stat</sub> [lbf]	C <sub>dyn</sub> [lbf]
<b>1</b>	1,872.2	82.28	67.80	5.43	76.02	75.83	5.20	4.09	80.51	72.83	52	24	4	68.35	14	-124	-0.28	-	4.09	30,034	60,069	3,021,657	229,755
<b>2</b>	2,446.4	103.54	88.74	5.43	97.28	97.09	5.20	4.09	101.77	93.90	66	24	6	89.29	14	-162	-0.28	-	4.09	30,034	60,069	3,847,380	250,887
<b>3</b>	2,695.0	111.02	95.75	5.43	104.76	104.57	5.20	4.09	109.25	101.57	72	24	6	96.38	16	-153	-0.31	-	4.09	34,328	68,657	4,147,500	258,081

## Internal gear KUD\_40\_ZJ

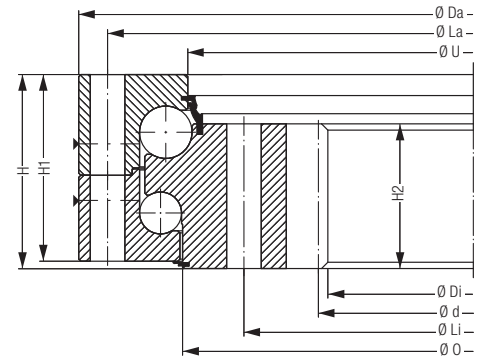
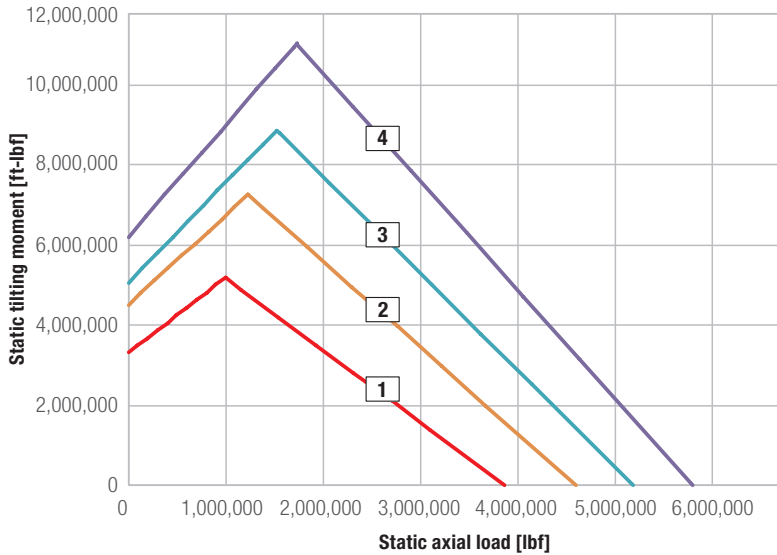

- 1 KUD02199-040ZJ15-900-000
- 2 KUD02622-040ZJ15-900-000
- 3 KUD02950-040ZJ15-900-000
- 4 KUD03300-040ZJ15-900-000

Bearing type	Bearing data								Bolt data					Gear data						Load rating			
	Weight	Outer diameter	Inner diameter	Total height	Outer diameter Inner ring	Inner diameter Outer ring	Height Outer ring	Height Inner ring	Pitch circle diameter Outer ring	Pitch circle diameter Inner ring	Number of bores per ring	Bolt diameter	Number of grease nipples per level	Pitch circle diameter	Module (metric)	Number of teeth	Profile shift	Tip reduction	Tooth width	Tooth forces (standard)	Tooth forces (maximum)	static	dynamic
	[lbs]	Da [inch]	Di [inch]	H [inch]	O [inch]	U [inch]	H1 [inch]	H2 [inch]	La [inch]	Li [inch]	n	M [mm]	n1	d [inch]	m [mm]	z	x*m [inch]	k*m [inch]	b [inch]	[lbf]	[lbf]	C <sub>stat</sub> [lbf]	C <sub>dyn</sub> [lbf]
1	2,723.6	92.52	75.59	6.14	85.35	85.20	5.91	4.61	90.35	81.30	52	30	4	76.22	16	-121	-0.31	-	4.61	36,576	73,175	3,873,233	274,941
2	3,289.0	109.06	91.97	6.14	101.97	101.85	5.91	4.61	106.89	97.83	60	30	6	92.60	16	-147	-0.31	-	4.61	36,576	73,175	4,608,359	292,926
3	3,880.8	122.05	104.17	6.14	114.88	114.76	5.91	4.61	119.88	110.83	60	30	6	104.88	18	-148	-0.35	-	4.61	41,163	82,325	5,196,684	306,415
4	4,257.0	135.83	118.35	6.14	128.66	128.54	5.91	4.61	133.66	124.61	66	30	6	119.06	18	-168	-0.35	-	4.61	41,163	82,325	5,809,513	319,004

## Internal gear KUD\_50\_ZJ

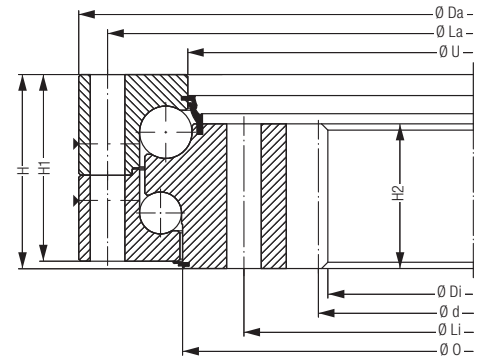
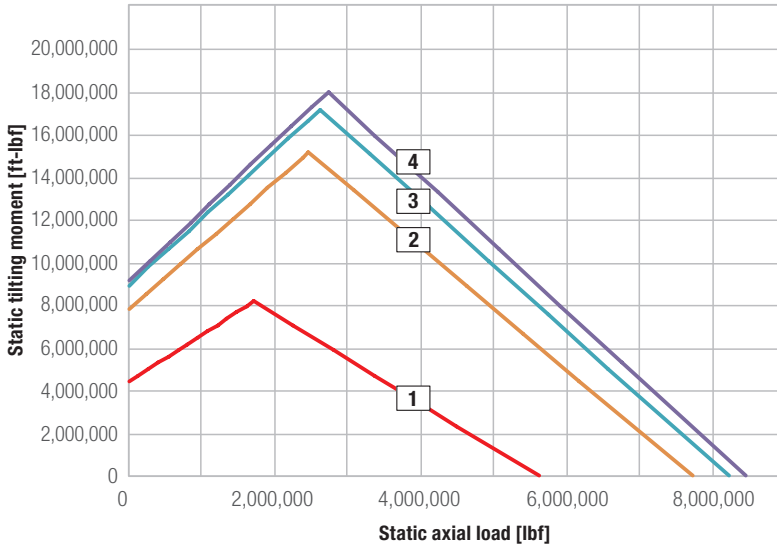

- 1 KUD02559-050ZJ15-900-000
- 2 KUD03520-050ZJ15-900-000
- 3 KUD03739-050ZJ15-900-000
- 4 KUD03839-050ZJ15-900-000

KUD\_Z

Bearing type	Bearing data								Bolt data						Gear data						Load rating		
	Weight	Outer diameter	Inner diameter	Total height	Outer diameter Inner ring	Inner diameter Outer ring	Height Outer ring	Height Inner ring	Pitch circle diameter Outer ring	Pitch circle diameter Inner ring	Number of bores per ring	Bolt diameter	Number of grease nipples per level	Pitch circle diameter	Module (metric)	Number of teeth	Profile shift	Tip reduction	Tooth width	Tooth forces (standard)	Tooth forces (maximum)	static	dynamic
	[lbs]	Da [inch]	Di [inch]	H [inch]	O [inch]	U [inch]	H1 [inch]	H2 [inch]	La [inch]	Li [inch]	n	M [mm]	n1	d [inch]	m [mm]	z	x*m [inch]	k*m [inch]	b [inch]	[lbf]	[lbf]	C <sub>stat</sub> [lbf]	C <sub>dyn</sub> [lbf]
1	4,162.4	107.28	88.58	7.28	99.37	99.29	6.93	5.43	105.12	94.88	60	30	6	89.29	18	-126	-0.354	-	5.433	48,558.7	97,117.5	5,630,565	365,989
2	5,845.4	145.08	125.98	7.28	137.20	137.09	6.93	5.43	142.91	132.68	78	30	6	126.77	20	-161	-0.394	-	5.433	53,954.1	107,908.3	7,736,800	411,176
3	6,210.6	153.74	134.65	7.28	145.83	145.71	6.93	5.43	151.57	141.34	84	30	6	135.43	20	-172	-0.394	-	5.433	53,954.1	107,908.3	8,234,752	420,842
4	6,391.0	157.68	138.58	7.28	149.76	149.65	6.93	5.43	155.51	145.28	84	30	6	139.37	20	-177	-0.394	-	5.433	53,954.1	107,908.3	8,464,506	425,339



# Technical data

KUD\_W Double-row ball bearings, four-point contact

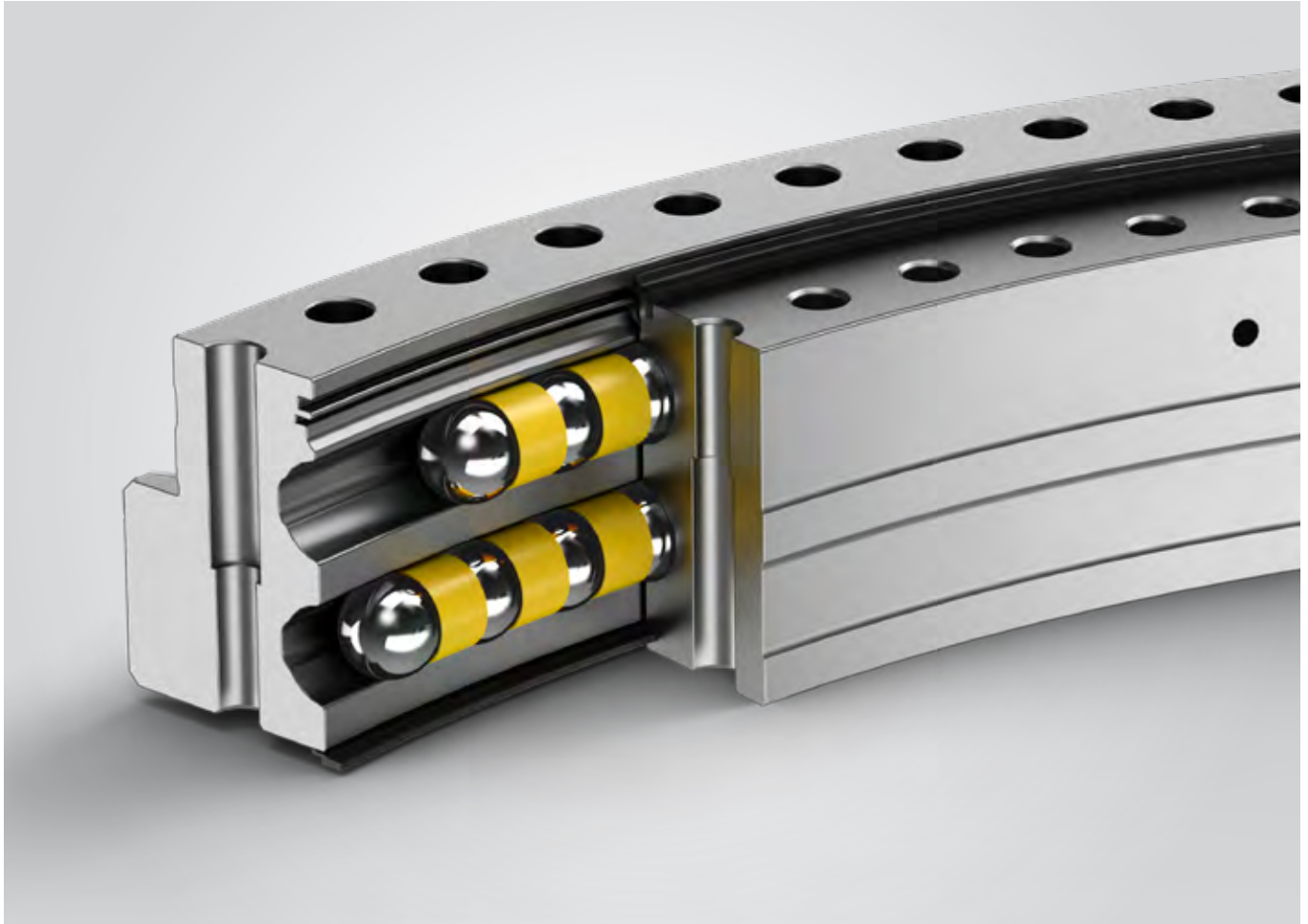

KUD\_W

**KUD\_WA**

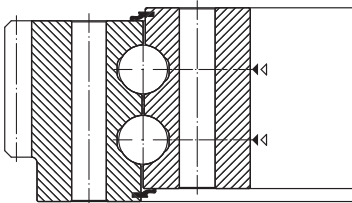

**KUD\_WJ**

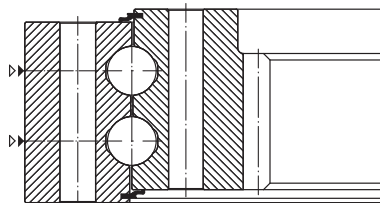

**KUD\_WO**

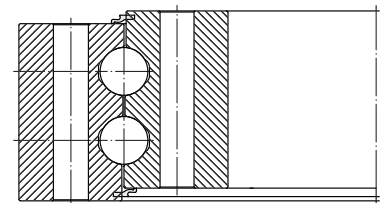

## External gear KUD\_30\_WA

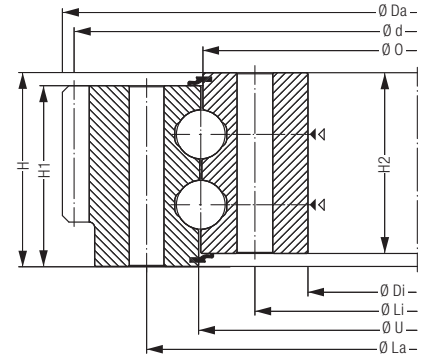
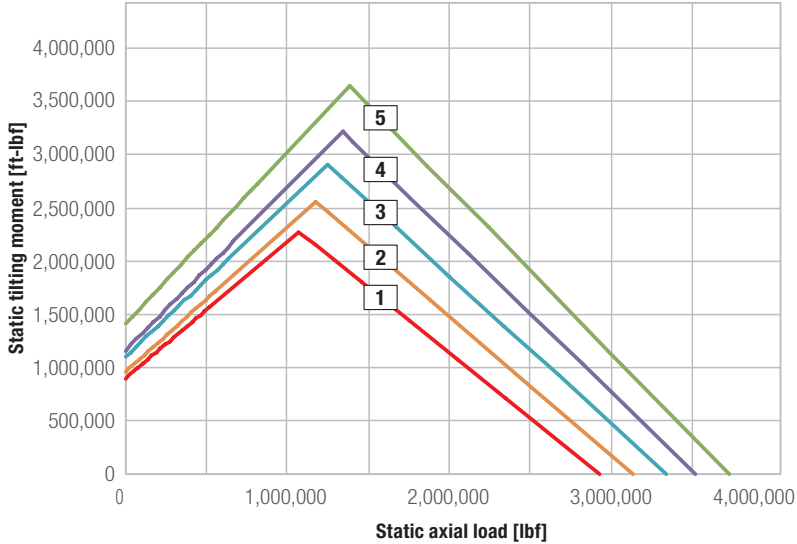

- 1 KUD01497-030WA15-900-000
- 2 KUD01597-030WA15-900-000
- 3 KUD01697-030WA15-900-000
- 4 KUD01797-030WA15-900-000
- 5 KUD01897-030WA15-900-000

Bearing type	Bearing data								Bolt data						Gear data						Load rating		
	Weight	Outer diameter	Inner diameter	Total height	Outer diameter Inner ring	Inner diameter Outer ring	Height Outer ring	Height Inner ring	Pitch circle diameter Outer ring	Pitch circle diameter Inner ring	Number of bores per ring	Bolt diameter	Number of grease nipples per level	Pitch circle diameter	Module (metric)	Number of teeth	Profile shift	Tip reduction	Tooth width	Tooth forces (standard)	Tooth forces (maximum)	static	dynamic
	[lbs]	Da [inch]	Di [inch]	H [inch]	O [inch]	U [inch]	H1 [inch]	H2 [inch]	La [inch]	Li [inch]	n	M [mm]	n1	d [inch]	m [mm]	z	x*m [inch]	k*m [inch]	b [inch]	[lbf]	[lbf]	C <sub>stat</sub> [lbf]	C <sub>dyn</sub> [lbf]
1	1,097.8	65.57	54.45	4.84	58.86	59.02	4.37	4.37	61.57	56.18	48	20	6	64.25	12	136	0.24	-0.047	4.370	28,931.9	57,863.9	2,927,462	235,600
2	1,155.0	69.35	58.39	4.84	62.79	62.95	4.37	4.37	65.51	60.12	48	20	6	68.03	12	144	0.24	-0.047	4.370	28,931.9	57,863.9	3,132,038	241,670
3	1,269.4	73.61	62.32	4.84	66.73	66.89	4.37	4.37	69.45	64.06	52	20	7	72.28	12	153	0.24	-0.047	4.370	28,931.9	57,863.9	3,336,614	247,739
4	1,324.4	77.39	66.26	4.84	70.67	70.83	4.37	4.37	73.39	67.99	52	20	7	76.06	12	161	0.24	-0.047	4.370	28,931.9	57,863.9	3,520,958	252,460
5	1,364.0	81.17	70.20	4.84	74.61	74.77	4.37	4.37	77.32	71.93	60	20	8	79.84	12	169	0.24	-0.047	4.370	28,931.9	57,863.9	3,725,534	257,856



## External gear KUD\_35\_WA

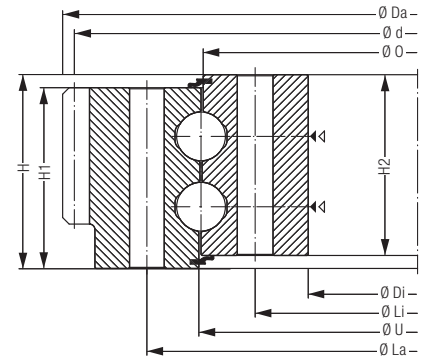
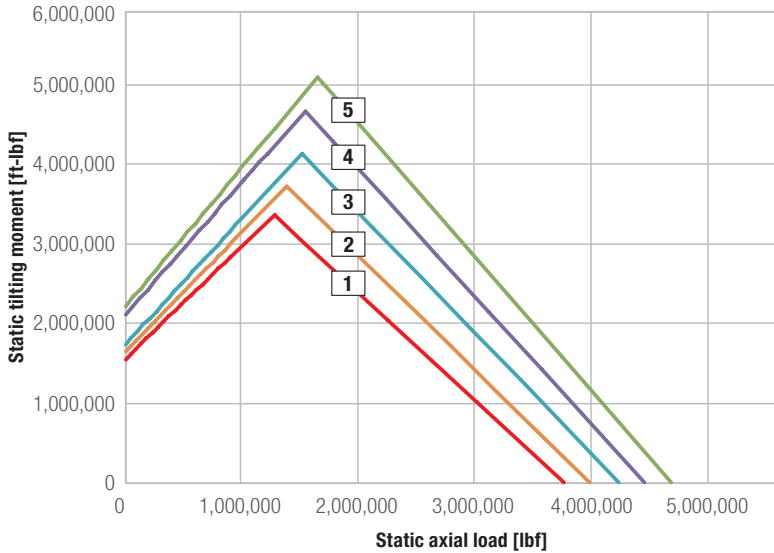

- 1 KUD01647-035WA15-900-000
- 2 KUD01747-035WA15-900-000
- 3 KUD01847-035WA15-900-000
- 4 KUD01947-035WA15-900-000
- 5 KUD02047-035WA15-900-000

KUD\_W

Bearing type	Bearing data								Bolt data					Gear data							Load rating		
	Weight	Outer diameter	Inner diameter	Total height	Outer diameter Inner ring	Inner diameter Outer ring	Height Outer ring	Height Inner ring	Pitch circle diameter Outer ring	Pitch circle diameter Inner ring	Number of bores per ring	Bolt diameter	Number of grease nipples per level	Pitch circle diameter	Module (metric)	Number of teeth	Profile shift	Tip reduction	Tooth width	Tooth forces (standard)	Tooth forces (maximum)	static	dynamic
	[lbs]	Da [inch]	Di [inch]	H [inch]	O [inch]	U [inch]	H1 [inch]	H2 [inch]	La [inch]	Li [inch]	n	M [mm]	n1	d [inch]	m [mm]	z	x*m [inch]	k*m [inch]	b [inch]	[lbf]	[lbf]	C <sub>stat</sub> [lbf]	C <sub>dyn</sub> [lbf]
1	1,520.2	72.19	59.61	5.39	64.76	64.92	4.92	4.92	67.91	61.65	52	24	7	70.87	12	150	0.24	-0.047	4.724	31,277.8	62,555.5	3,761,503	286,407
2	1,592.8	75.97	63.54	5.39	68.70	68.86	4.92	4.92	71.85	65.59	52	24	7	74.65	12	158	0.24	-0.047	4.724	31,277.8	62,555.5	3,984,514	292,252
3	1,744.6	80.22	67.48	5.39	72.64	72.80	4.92	4.92	75.79	69.53	52	24	7	78.90	12	167	0.24	-0.047	4.724	31,277.8	62,555.5	4,235,176	299,446
4	1,797.4	84.00	71.42	5.39	76.57	76.73	4.92	4.92	79.72	73.46	60	24	8	82.68	12	175	0.24	-0.047	4.724	31,277.8	62,555.5	4,457,961	305,066
5	2,015.2	88.63	75.35	5.39	80.52	80.68	4.92	4.92	83.66	77.40	60	24	8	87.09	14	158	0.28	-0.055	4.921	36,110.6	72,221.2	4,680,972	310,461

## External gear KUD\_40\_WA

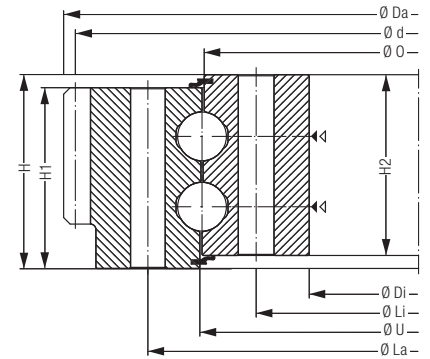
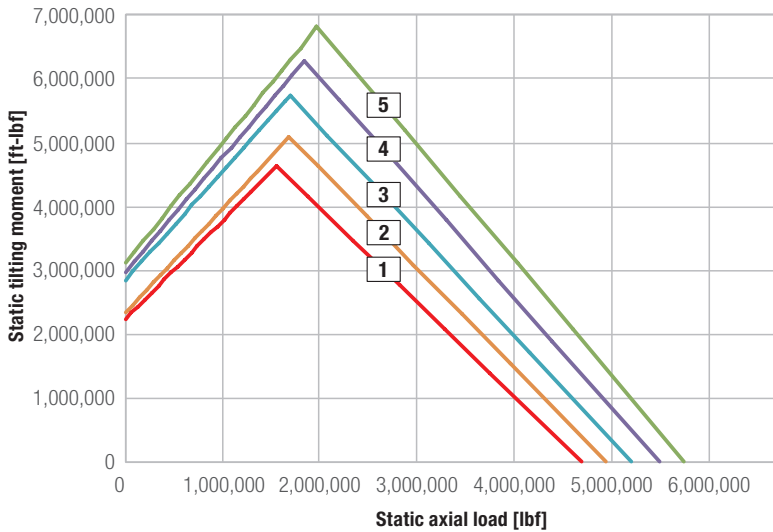

- 1 KUD01797-040WA15-900-000
- 2 KUD01897-040WA15-900-000
- 3 KUD01997-040WA15-900-000
- 4 KUD02097-040WA15-900-000
- 5 KUD02197-040WA15-900-000

Bearing type	Bearing data						Bolt data						Gear data						Load rating				
	Weight	Outer diameter	Inner diameter	Total height	Outer diameter Inner ring	Inner diameter Outer ring	Height Outer ring	Height Inner ring	Pitch circle diameter Outer ring	Pitch circle diameter Inner ring	Number of bores per ring	Bolt diameter	Number of grease nipples per level	Pitch circle diameter	Module (metric)	Number of teeth	Profile shift	Tip reduction	Tooth width	Tooth forces (standard)	Tooth forces (maximum)	static	dynamic
	[lbs]	Da [inch]	Di [inch]	H [inch]	O [inch]	U [inch]	H1 [inch]	H2 [inch]	La [inch]	Li [inch]	n	M [mm]	n1	d [inch]	m [mm]	z	x*m [inch]	k*m [inch]	b [inch]	[lbf]	[lbf]	C <sub>stat</sub> [lbf]	C <sub>dyn</sub> [lbf]
1	2,065.8	78.80	64.80	6.06	70.67	70.83	5.59	5.59	74.21	67.17	52	27	7	77.48	12	164	0.24	-0.05	4.72	29,713.9	59,427.8	4,694,910	339,462
2	2,160.4	82.58	68.74	6.06	74.61	74.77	5.59	5.59	78.15	71.10	52	27	7	81.26	12	172	0.24	-0.05	4.72	29,713.9	59,427.8	4,949,619	345,981
3	2,360.6	86.98	72.68	6.06	78.54	78.70	5.59	5.59	82.09	75.04	60	27	7	85.43	14	155	0.28	-0.06	5.51	40,443.9	80,887.8	5,204,102	352,500
4	2,470.6	90.83	76.61	6.06	82.48	82.64	5.59	5.59	86.02	78.98	60	27	8	89.29	14	162	0.28	-0.06	5.51	40,443.9	80,887.8	5,495,230	360,144
5	2,578.4	94.69	80.55	6.06	86.42	86.58	5.59	5.59	89.96	82.91	60	27	8	93.15	14	169	0.28	-0.06	5.51	40,443.9	80,887.8	5,749,938	365,989

## External gear KUD\_45\_WA

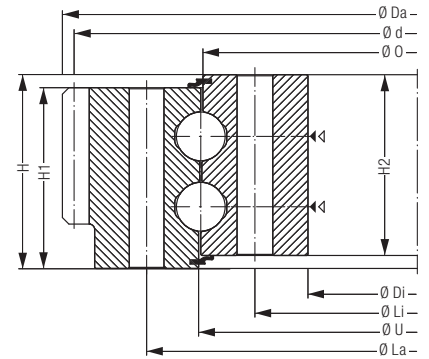
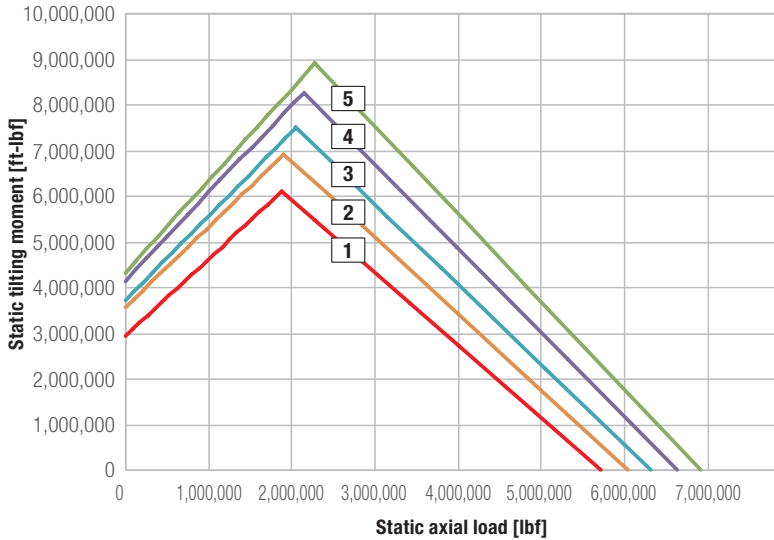

- 1 KUD01947-045WA15-900-000
- 2 KUD02047-045WA15-900-000
- 3 KUD02147-045WA15-900-000
- 4 KUD02247-045WA15-900-000
- 5 KUD02347-045WA15-900-000

KUD\_W

Bearing type	Bearing data								Bolt data					Gear data							Load rating		
	Weight	Outer diameter	Inner diameter	Total height	Outer diameter Inner ring	Inner diameter Outer ring	Height Outer ring	Height Inner ring	Pitch circle diameter Outer ring	Pitch circle diameter Inner ring	Number of bores per ring	Bolt diameter	Number of grease nipples per level	Pitch circle diameter	Module (metric)	Number of teeth	Profile shift	Tip reduction	Tooth width	Tooth forces (standard)	Tooth forces (maximum)	static	dynamic
	[lbs]	Da [inch]	Di [inch]	H [inch]	O [inch]	U [inch]	H1 [inch]	H2 [inch]	La [inch]	Li [inch]	n	M [mm]	n1	d [inch]	m [mm]	z	x*m [inch]	k*m [inch]	b [inch]	[lbf]	[lbf]	C <sub>stat</sub> [lbf]	C <sub>dyn</sub> [lbf]
1	2,710.4	85.42	70.08	6.69	76.57	76.73	6.22	6.22	80.51	72.68	52	30	8	84.09	12	178	0.24	-0.05	4.72	29,713.9	59,427.8	5,711,721	394,315
2	2,923.8	89.73	74.02	6.69	80.51	80.67	6.22	6.22	84.45	76.61	60	30	8	88.19	14	160	0.28	-0.06	5.51	40,443.9	80,887.8	6,034,097	403,082
3	3,060.2	93.59	77.95	6.69	84.45	84.61	6.22	6.22	88.39	80.55	60	30	8	92.05	14	167	0.28	-0.06	5.51	40,443.9	80,887.8	6,310,387	410,052
4	3,174.6	97.45	81.89	6.69	88.38	88.54	6.22	6.22	92.32	84.49	64	30	9	95.91	14	174	0.28	-0.06	5.51	40,443.9	80,887.8	6,586,452	415,672
5	3,308.8	101.31	85.83	6.69	92.32	92.48	6.22	6.22	96.26	88.43	64	30	9	99.76	14	181	0.28	-0.06	5.51	40,443.9	80,887.8	6,908,828	423,540

## External gear KUD\_50\_WA

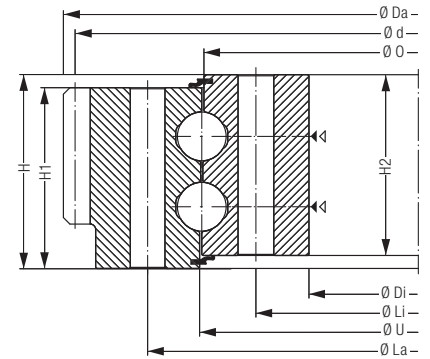
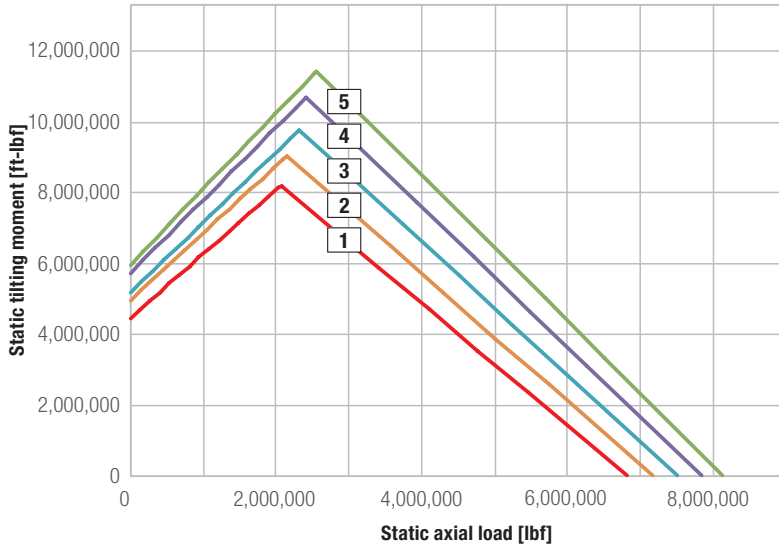

- 1 KUD02097-050WA15-900-000
- 2 KUD02197-050WA15-900-000
- 3 KUD02297-050WA15-900-000
- 4 KUD02397-050WA15-900-000
- 5 KUD02497-050WA15-900-000

Bearing type	Bearing data								Bolt data					Gear data							Load rating		
	Weight	Outer diameter	Inner diameter	Total height	Outer diameter Inner ring	Inner diameter Outer ring	Height Outer ring	Height Inner ring	Pitch circle diameter Outer ring	Pitch circle diameter Inner ring	Number of bores per ring	Bolt diameter	Number of grease nipples per level	Pitch circle diameter	Module (metric)	Number of teeth	Profile shift	Tip reduction	Tooth width	Tooth forces (standard)	Tooth forces (maximum)	static	dynamic
	[lbs]	Da [inch]	Di [inch]	H [inch]	O [inch]	U [inch]	H1 [inch]	H2 [inch]	La [inch]	Li [inch]	n	M [mm]	n1	d [inch]	m [mm]	z	x*m [inch]	k*m [inch]	b [inch]	[lbf]	[lbf]	C <sub>stat</sub> [lbf]	C <sub>dyn</sub> [lbf]
1	3,506.8	92.49	75.39	7.24	82.48	82.64	6.77	6.77	86.77	78.23	60	33	8	90.94	14	165	0.28	-0.06	5.51	38,315.3	76,630.5	6,824,075	451,192
2	3,645.4	96.35	79.33	7.24	86.42	86.58	6.77	6.77	90.71	82.17	64	33	8	94.80	14	172	0.28	-0.06	5.51	38,315.3	76,630.5	7,165,111	459,734
3	3,808.2	100.20	83.27	7.24	90.35	90.51	6.77	6.77	94.65	86.10	64	33	8	98.66	14	179	0.28	-0.06	5.51	38,315.3	76,630.5	7,506,146	468,052
4	3,944.6	104.06	87.20	7.24	94.29	94.45	6.77	6.77	98.58	90.04	68	33	10	102.52	14	186	0.28	-0.06	5.51	38,315.3	76,630.5	7,847,406	476,145
5	4,103.0	107.92	91.14	7.24	98.23	98.39	6.77	6.77	102.52	93.98	68	33	10	106.38	14	193	0.28	-0.06	5.51	38,315.3	76,630.5	8,131,564	481,541

## Internal gear KUD\_30\_WJ

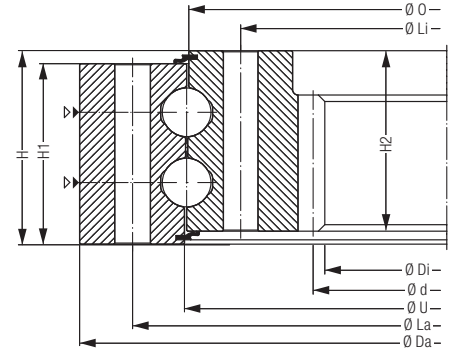
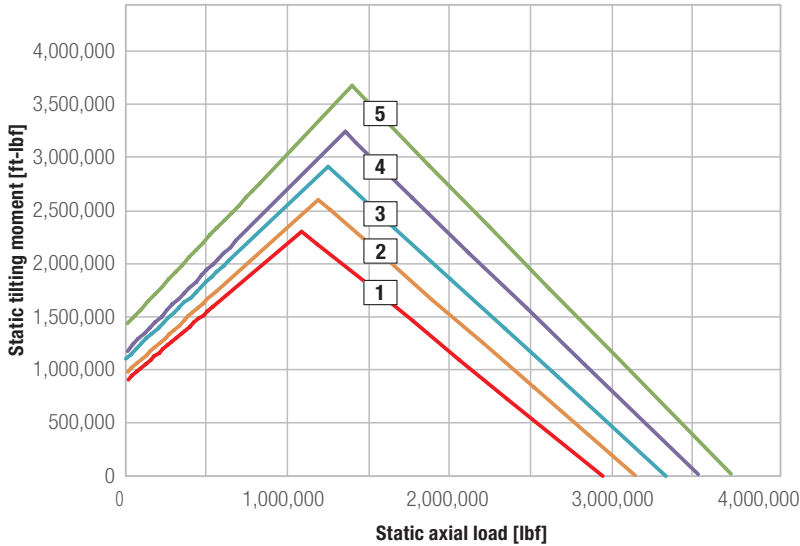

- 1 KUD01506-030WJ15-900-000
- 2 KUD01606-030WJ15-900-000
- 3 KUD01706-030WJ15-900-000
- 4 KUD01806-030WJ15-900-000
- 5 KUD01906-030WJ15-900-000

KUD\_W

Bearing type	Bearing data								Bolt data						Gear data						Load rating		
	Weight	Outer diameter	Inner diameter	Total height	Outer diameter Inner ring	Inner diameter Outer ring	Height Outer ring	Height Inner ring	Pitch circle diameter Outer ring	Pitch circle diameter Inner ring	Number of bores per ring	Bolt diameter	Number of grease nipples per level	Pitch circle diameter	Module (metric)	Number of teeth	Profile shift	Tip reduction	Tooth width	Tooth forces (standard)	Tooth forces (maximum)	static	dynamic
	[lbs]	Da [inch]	Di [inch]	H [inch]	O [inch]	U [inch]	H1 [inch]	H2 [inch]	La [inch]	Li [inch]	n	M [mm]	n1	d [inch]	m [mm]	z	x*m [inch]	k*m [inch]	b [inch]	[lbf]	[lbf]	C <sub>stat</sub> [lbf]	C <sub>dyn</sub> [lbf]
1	1,073.6	63.66	52.54	4.84	59.21	59.37	4.37	4.37	61.93	56.54	48	20	6	52.91	12	-112	-0.24	-0.047	4.370	28,931.9	57,863.9	2,947,920	236,274
2	1,168.2	67.60	56.31	4.84	63.15	63.31	4.37	4.37	65.87	60.47	48	20	6	56.69	12	-120	-0.24	-0.047	4.370	28,931.9	57,863.9	3,152,496	242,344
3	1,203.4	71.54	60.57	4.84	67.09	67.25	4.37	4.37	69.80	64.41	52	20	7	60.94	12	-129	-0.24	-0.047	4.370	28,931.9	57,863.9	3,336,614	247,290
4	1,298.0	75.47	64.35	4.84	71.02	71.18	4.37	4.37	73.74	68.35	52	20	7	64.72	12	-137	-0.24	-0.047	4.370	28,931.9	57,863.9	3,541,415	252,910
5	1,386.0	79.41	68.13	4.84	74.96	75.12	4.37	4.37	77.68	72.28	60	20	8	68.50	12	-145	-0.24	-0.047	4.370	28,931.9	57,863.9	3,745,991	258,530

## Internal gear KUD\_35\_WJ

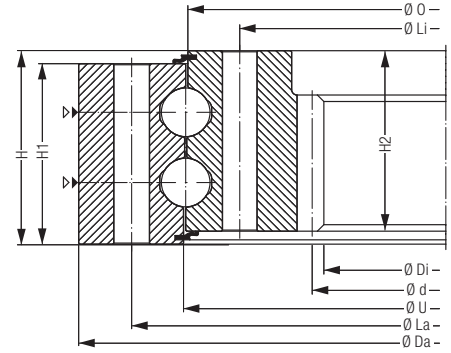
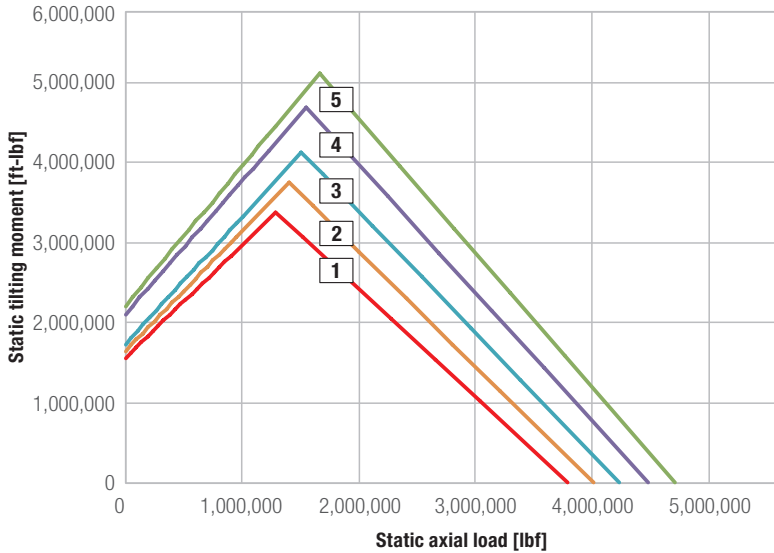

- 1 KUD01656-035WJ15-900-000
- 2 KUD01756-035WJ15-900-000
- 3 KUD01856-035WJ15-900-000
- 4 KUD01956-035WJ15-900-000
- 5 KUD02056-035WJ15-900-000

Bearing type	Bearing data								Bolt data					Gear data							Load rating		
	Weight	Outer diameter	Inner diameter	Total height	Outer diameter Inner ring	Inner diameter Outer ring	Height Outer ring	Height Inner ring	Pitch circle diameter Outer ring	Pitch circle diameter Inner ring	Number of bores per ring	Bolt diameter	Number of grease nipples per level	Pitch circle diameter	Module (metric)	Number of teeth	Profile shift	Tip reduction	Tooth width	Tooth forces (standard)	Tooth forces (maximum)	static	dynamic
	[lbs]	Da [inch]	Di [inch]	H [inch]	O [inch]	U [inch]	H1 [inch]	H2 [inch]	La [inch]	Li [inch]	n	M	n1	d [inch]	m [mm]	z	x*m [inch]	k*m [inch]	b [inch]	[lbf]	[lbf]	C <sub>stat</sub> [lbf]	C <sub>dyn</sub> [lbf]
1	1,491.6	70.31	57.73	5.39	65.12	65.28	4.92	4.92	68.27	62.01	52	24	7	58.11	12	-123	-0.24	-0.05	4.72	31,277.8	62,555.5	3,789,380	287,306
2	1,610.4	74.25	61.51	5.39	69.05	69.21	4.92	4.92	72.20	65.94	52	24	7	61.89	12	-131	-0.24	-0.05	4.72	31,277.8	62,555.5	4,012,390	293,151
3	1,667.6	78.19	65.76	5.39	72.99	73.15	4.92	4.92	76.14	69.88	52	24	7	66.14	12	-140	-0.24	-0.05	4.72	31,277.8	62,555.5	4,235,176	298,996
4	1,768.8	82.13	69.54	5.39	76.93	77.09	4.92	4.92	80.08	73.82	60	24	8	69.92	12	-148	-0.24	-0.05	4.72	31,277.8	62,555.5	4,485,838	305,965
5	1,953.6	86.06	72.87	5.39	80.86	81.02	4.92	4.92	84.02	77.76	60	24	8	73.31	14	-133	-0.28	-0.06	4.92	36,110.6	72,221.2	4,708,848	311,360

## Internal gear KUD\_40\_WJ

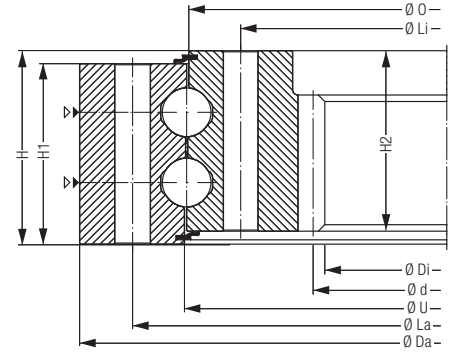
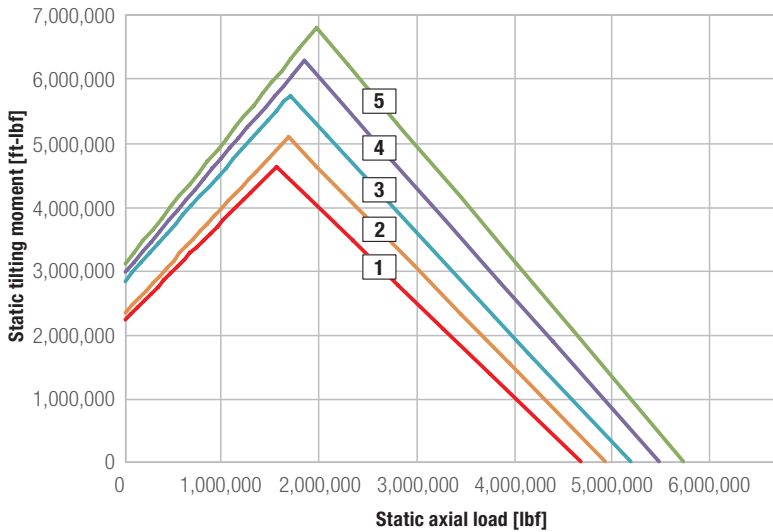

- 1 KUD01806-040WJ15-900-000
- 2 KUD01906-040WJ15-900-000
- 3 KUD02006-040WJ15-900-000
- 4 KUD02106-040WJ15-900-000
- 5 KUD02206-040WJ15-900-000

KUD\_W

Bearing type	Bearing data								Bolt data					Gear data							Load rating		
	Weight	Outer diameter	Inner diameter	Total height	Outer diameter Inner ring	Inner diameter Outer ring	Height Outer ring	Height Inner ring	Pitch circle diameter Outer ring	Pitch circle diameter Inner ring	Number of bores per ring	Bolt diameter	Number of grease nipples per level	Pitch circle diameter	Module (metric)	Number of teeth	Profile shift	Tip reduction	Tooth width	Tooth forces (standard)	Tooth forces (maximum)	static	dynamic
	[lbs]	Da [inch]	Di [inch]	H [inch]	O [inch]	U [inch]	H1 [inch]	H2 [inch]	La [inch]	Li [inch]	n	M [mm]	n1	d [inch]	m [mm]	z	x*m [inch]	k*m [inch]	b [inch]	[lbf]	[lbf]	C <sub>stat</sub> [lbf]	C <sub>dyn</sub> [lbf]
1	2,035.0	76.93	62.93	6.06	71.02	71.18	5.59	5.59	74.57	67.52	52	27	7	63.31	12	-134	-0.24	-0.05	4.72	29,713.9	59,427.8	4,731,104	340,810
2	2,180.2	80.87	66.71	6.06	74.96	75.12	5.59	5.59	78.50	71.46	52	27	7	67.09	12	-142	-0.24	-0.05	4.72	29,713.9	59,427.8	4,985,813	347,330
3	2,290.2	84.80	70.66	6.06	78.90	79.06	5.59	5.59	82.44	75.39	60	27	7	71.10	14	-129	-0.28	-0.06	5.51	40,443.9	80,887.8	5,240,521	353,624
4	2,428.8	88.74	74.52	6.06	82.83	82.99	5.59	5.59	86.38	79.33	60	27	8	74.96	14	-136	-0.28	-0.06	5.51	40,443.9	80,887.8	5,495,230	359,694
5	2,571.8	92.68	78.38	6.06	86.77	86.93	5.59	5.59	90.31	83.27	60	27	8	78.82	14	-143	-0.28	-0.06	5.51	40,443.9	80,887.8	5,749,938	365,539

## Internal gear KUD\_45\_WJ

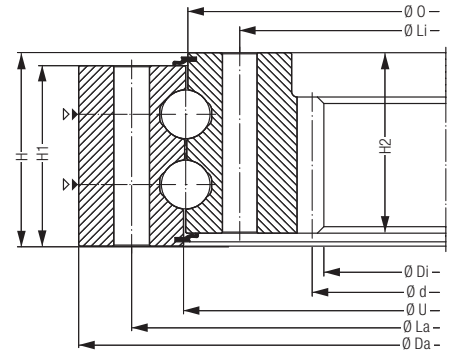
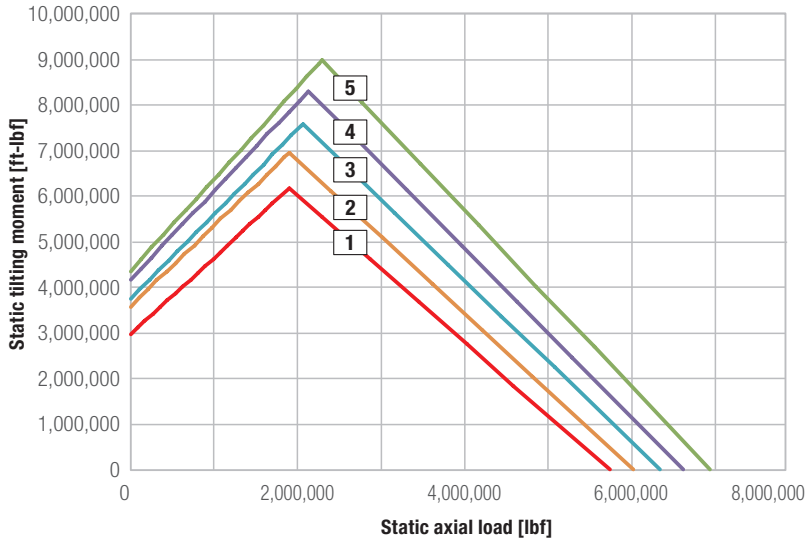

- 1 KUD01956-045WJ15-900-000
- 2 KUD02056-045WJ15-900-000
- 3 KUD02156-045WJ15-900-000
- 4 KUD02256-045WJ15-900-000
- 5 KUD02356-045WJ15-900-000

Bearing type	Bearing data								Bolt data					Gear data						Load rating			
	Weight	Outer diameter	Inner diameter	Total height	Outer diameter Inner ring	Inner diameter Outer ring	Height Outer ring	Height Inner ring	Pitch circle diameter Outer ring	Pitch circle diameter Inner ring	Number of bores per ring	Bolt diameter	Number of grease nipples per level	Pitch circle diameter	Module (metric)	Number of teeth	Profile shift	Tip reduction	Tooth width	Tooth forces (standard)	Tooth forces (maximum)	static	dynamic
	[lbs]	Da [inch]	Di [inch]	H [inch]	O [inch]	U [inch]	H1 [inch]	H2 [inch]	La [inch]	Li [inch]	n	M [mm]	n1	d [inch]	m [mm]	z	x*m [inch]	k*m [inch]	b [inch]	[lbf]	[lbf]	C <sub>stat</sub> [lbf]	C <sub>dyn</sub> [lbf]
1	2,675.2	83.46	68.13	6.69	76.93	77.09	6.22	6.22	80.87	73.03	52	30	8	68.50	12	-145	-0.24	-0.05	4.72	29,713.9	59,427.8	5,757,807	395,889
2	2,855.6	87.40	71.76	6.69	80.86	81.02	6.22	6.22	84.80	76.97	60	30	8	72.20	14	-131	-0.28	-0.06	5.51	40,443.9	80,887.8	6,034,097	402,408
3	3,022.8	91.34	75.62	6.69	84.80	84.96	6.22	6.22	88.74	80.91	60	30	8	76.06	14	-138	-0.28	-0.06	5.51	40,443.9	80,887.8	6,356,248	410,726
4	3,174.6	95.28	79.48	6.69	88.74	88.90	6.22	6.22	92.68	84.84	64	30	9	79.92	14	-145	-0.28	-0.06	5.51	40,443.9	80,887.8	6,632,538	417,021
5	3,346.2	99.21	83.34	6.69	92.68	92.84	6.22	6.22	96.61	88.78	64	30	9	83.78	14	-152	-0.28	-0.06	5.51	40,443.9	80,887.8	6,908,828	423,090



## Internal gear KUD\_50\_WJ

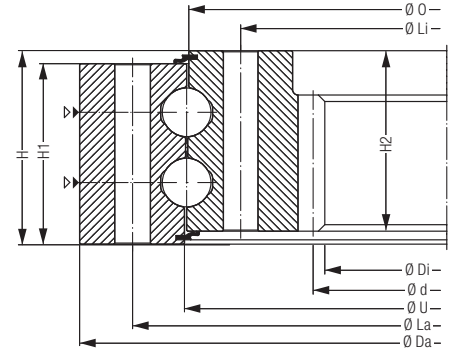
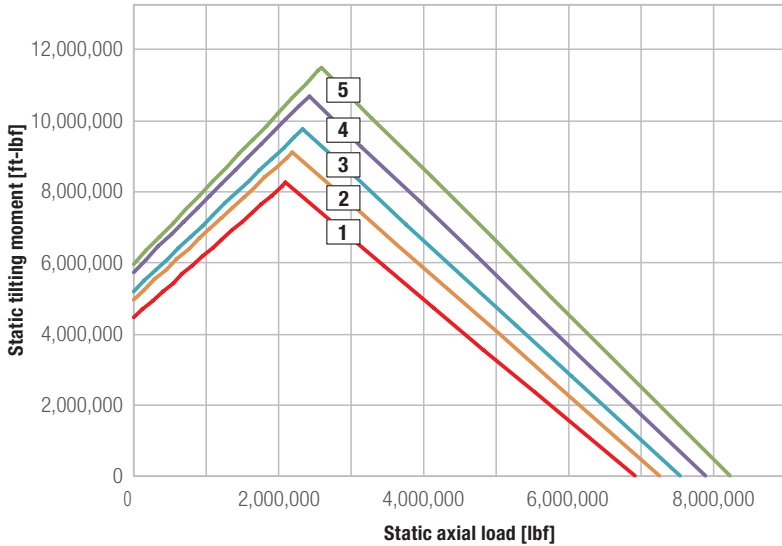

- 1 KUD02106-050WJ15-900-000
- 2 KUD02206-050WJ15-900-000
- 3 KUD02306-050WJ15-900-000
- 4 KUD02406-050WJ15-900-000
- 5 KUD02506-050WJ15-900-000

KUD\_W

Bearing type	Bearing data							Bolt data							Gear data							Load rating	
	Weight	Outer diameter	Inner diameter	Total height	Outer diameter Inner ring	Inner diameter Outer ring	Height Outer ring	Height Inner ring	Pitch circle diameter Outer ring	Pitch circle diameter Inner ring	Number of bores per ring	Bolt diameter	Number of grease nipples per level	Pitch circle diameter	Module (metric)	Number of teeth	Profile shift	Tip reduction	Tooth width	Tooth forces (standard)	Tooth forces (maximum)	static	dynamic
	[lbs]	Da [inch]	Di [inch]	H [inch]	O [inch]	U [inch]	H1 [inch]	H2 [inch]	La [inch]	Li [inch]	n	M	n1	d [inch]	m [mm]	z	x*m [inch]	k*m [inch]	b [inch]	[lbf]	[lbf]	C <sub>stat</sub> [lbf]	C <sub>dyn</sub> [lbf]
1	3,440.8	89.96	72.87	7.24	82.83	82.99	6.77	6.77	87.13	78.58	60	33	8	73.31	14	-133	-0.28	-0.06	5.51	38,315.3	76,630.5	6,880,952	453,215
2	3,509.0	93.90	77.28	7.24	86.77	86.93	6.77	6.77	91.06	82.52	64	33	8	77.72	14	-141	-0.28	-0.06	5.51	38,315.3	76,630.5	7,221,987	461,758
3	3,702.6	97.83	81.13	7.24	90.71	90.87	6.77	6.77	95.00	86.46	64	33	8	81.57	14	-148	-0.28	-0.06	5.51	38,315.3	76,630.5	7,506,146	467,603
4	3,872.0	101.77	84.99	7.24	94.64	94.80	6.77	6.77	98.94	90.39	68	33	10	85.43	14	-155	-0.28	-0.06	5.51	38,315.3	76,630.5	7,847,406	475,471
5	4,070.0	105.71	88.85	7.24	98.58	98.74	6.77	6.77	102.87	94.33	68	33	10	89.29	14	-162	-0.28	-0.06	5.51	38,315.3	76,630.5	8,188,441	483,339

## No gearing KUD\_30\_WO

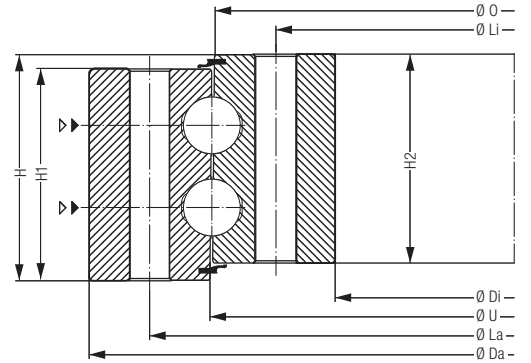
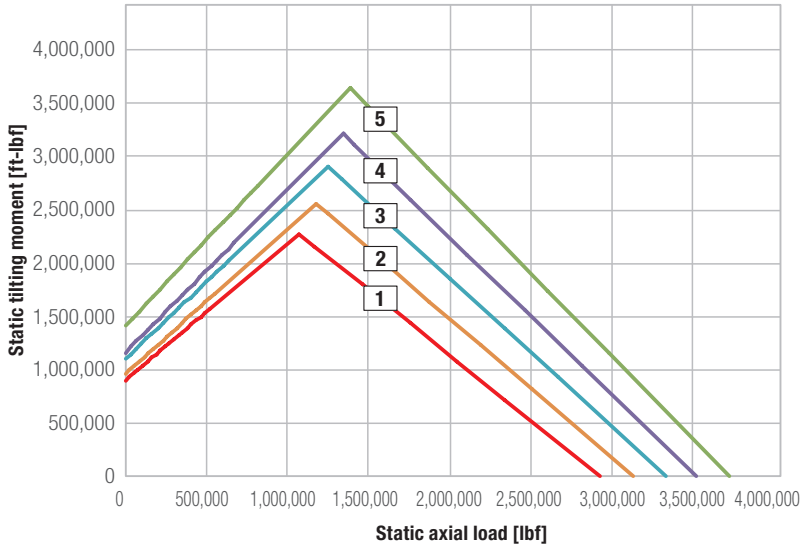

- 1 KUD01497-030W015-900-000
- 2 KUD01597-030W015-900-000
- 3 KUD01697-030W015-900-000
- 4 KUD01797-030W015-900-000
- 5 KUD01897-030W015-900-000

Bearing type	Bearing data								Bolt data						Gear data						Load rating		
	Weight	Outer diameter	Inner diameter	Total height	Outer diameter Inner ring	Inner diameter Outer ring	Height Outer ring	Height Inner ring	Pitch circle diameter Outer ring	Pitch circle diameter Inner ring	Number of bores per ring	Bolt diameter	Number of grease nipples per level	Pitch circle diameter	Module (metric)	Number of teeth	Profile shift	Tip reduction	Tooth width	Tooth forces (standard)	Tooth forces (maximum)	static	dynamic
	[lbs]	Da [inch]	Di [inch]	H [inch]	O [inch]	U [inch]	H1 [inch]	H2 [inch]	La [inch]	Li [inch]	n	M [mm]	n1	d [inch]	m [mm]	z	x*m [inch]	k*m [inch]	b [inch]	[lbf]	[lbf]	C <sub>stat</sub> [lbf]	C <sub>dyn</sub> [lbf]
1	919.6	63.31	54.45	4.84	58.86	59.02	4.37	4.37	61.57	56.18	48	20	6	-	-	-	-	-	-	-	-	2,927,462	235,600
2	985.6	67.24	58.39	4.84	62.79	62.95	4.37	4.37	65.51	60.12	48	20	6	-	-	-	-	-	-	-	-	3,132,038	241,670
3	1,045.0	71.18	62.32	4.84	66.73	66.89	4.37	4.37	69.45	64.06	52	20	7	-	-	-	-	-	-	-	-	3,336,614	247,739
4	1,111.0	75.12	66.26	4.84	70.67	70.83	4.37	4.37	73.39	67.99	52	20	7	-	-	-	-	-	-	-	-	3,520,958	252,460
5	1,166.0	79.06	70.20	4.84	74.61	74.77	4.37	4.37	77.32	71.93	60	20	8	-	-	-	-	-	-	-	-	3,725,534	257,856

## No gearing KUD\_35\_WO

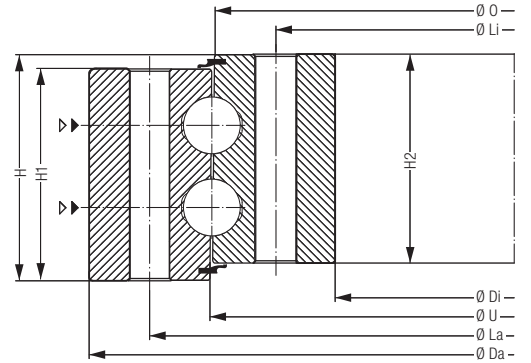
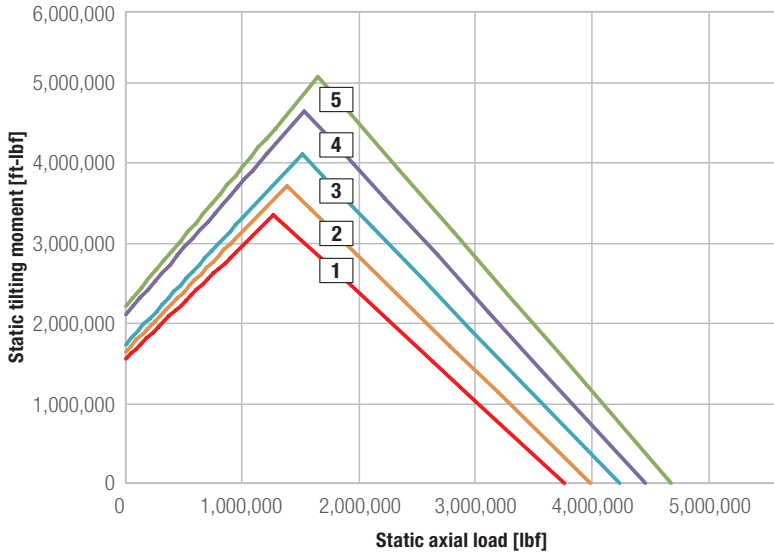

- 1 KUD01647-035W015-900-000
- 2 KUD01747-035W015-900-000
- 3 KUD01847-035W015-900-000
- 4 KUD01947-035W015-900-000
- 5 KUD02047-035W015-900-000

KUD\_W

Bearing type	Bearing data								Bolt data					Gear data							Load rating		
	Weight	Outer diameter	Inner diameter	Total height	Outer diameter Inner ring	Inner diameter Outer ring	Height Outer ring	Height Inner ring	Pitch circle diameter Outer ring	Pitch circle diameter Inner ring	Number of bores per ring	Bolt diameter	Number of grease nipples per level	Pitch circle diameter	Module (metric)	Number of teeth	Profile shift	Tip reduction	Tooth width	Tooth forces (standard)	Tooth forces (maximum)	static	dynamic
	[lbs]	Da [inch]	Di [inch]	H [inch]	O [inch]	U [inch]	H1 [inch]	H2 [inch]	La [inch]	Li [inch]	n	M [mm]	n1	d [inch]	m [mm]	z	x*m [inch]	k*m [inch]	b [inch]			C <sub>stat</sub> [lbf]	C <sub>dyn</sub> [lbf]
1	1,313.4	69.96	59.61	5.39	64.76	64.92	4.92	4.92	67.91	61.65	52	24	7	-	-	-	-	-	-	-	-	3,761,503	286,407
2	1,399.2	73.90	63.54	5.39	68.70	68.86	4.92	4.92	71.85	65.59	52	24	7	-	-	-	-	-	-	-	-	3,984,514	292,252
3	1,487.2	77.83	67.48	5.39	72.64	72.80	4.92	4.92	75.79	69.53	52	24	7	-	-	-	-	-	-	-	-	4,235,176	299,446
4	1,555.4	81.77	71.42	5.39	76.57	76.73	4.92	4.92	79.72	73.46	60	24	8	-	-	-	-	-	-	-	-	4,457,961	305,066
5	1,641.2	85.71	75.35	5.39	80.52	80.68	4.92	4.92	83.66	77.40	60	24	8	-	-	-	-	-	-	-	-	4,680,972	310,461

## No gearing KUD\_40\_WO

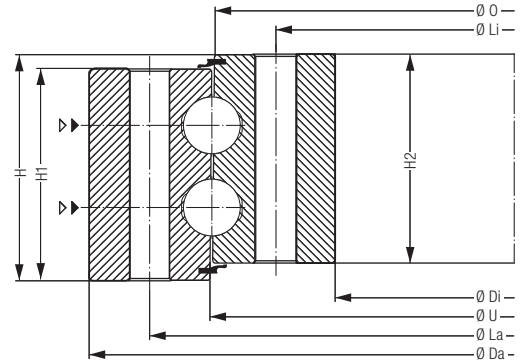
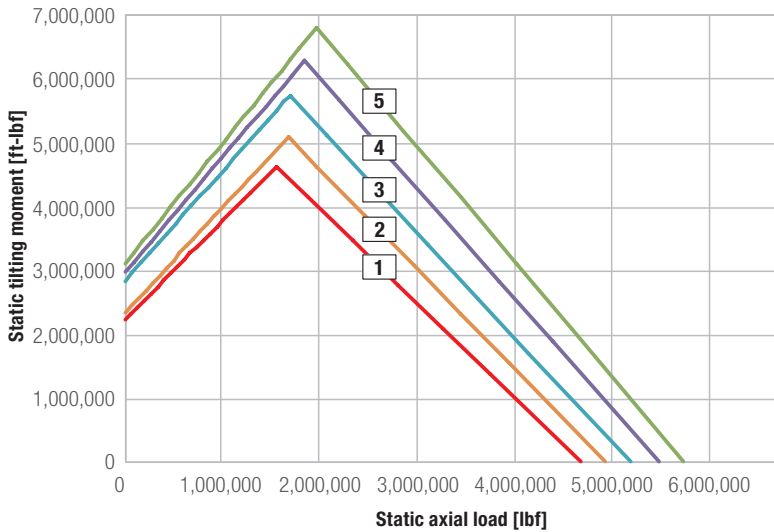

- 1 KUD01797-040W015-900-000
- 2 KUD01897-040W015-900-000
- 3 KUD01997-040W015-900-000
- 4 KUD02097-040W015-900-000
- 5 KUD02197-040W015-900-000

Bearing type	Bearing data								Bolt data					Gear data							Load rating		
	Weight	Outer diameter	Inner diameter	Total height	Outer diameter Inner ring	Inner diameter Outer ring	Height Outer ring	Height Inner ring	Pitch circle diameter Outer ring	Pitch circle diameter Inner ring	Number of bores per ring	Bolt diameter	Number of grease nipples per level	Pitch circle diameter	Module (metric)	Number of teeth	Profile shift	Tip reduction	Tooth width	Tooth forces (standard)	Tooth forces (maximum)	static	dynamic
	[lbs]	Da [inch]	Di [inch]	H [inch]	O [inch]	U [inch]	H1 [inch]	H2 [inch]	La [inch]	Li [inch]	n	M	n1	d [inch]	m [mm]	z	x*m [inch]	k*m [inch]	b [inch]	[lbf]	[lbf]	C <sub>stat</sub> [lbf]	C <sub>dyn</sub> [lbf]
1	1,837.0	76.57	64.80	6.06	70.67	70.83	5.59	5.59	74.21	67.17	52	27	7	-	-	-	-	-	-	-	-	4,694,910	339,462
2	1,949.2	80.51	68.74	6.06	74.61	74.77	5.59	5.59	78.15	71.10	52	27	8	-	-	-	-	-	-	-	-	4,949,619	345,981
3	2,035.0	84.45	72.68	6.06	78.54	78.70	5.59	5.59	82.09	75.04	60	27	8	-	-	-	-	-	-	-	-	5,204,102	352,500
4	2,147.2	88.39	76.61	6.06	82.48	82.64	5.59	5.59	86.02	78.98	60	27	8	-	-	-	-	-	-	-	-	5,495,230	360,144
5	2,259.4	92.32	80.55	6.06	86.42	86.58	5.59	5.59	89.96	82.91	60	27	9	-	-	-	-	-	-	-	-	5,749,938	365,989

## No gearing KUD\_45\_WO

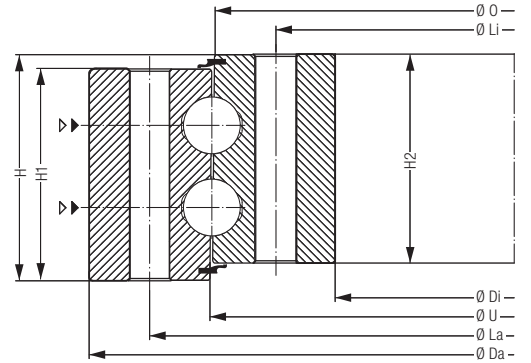
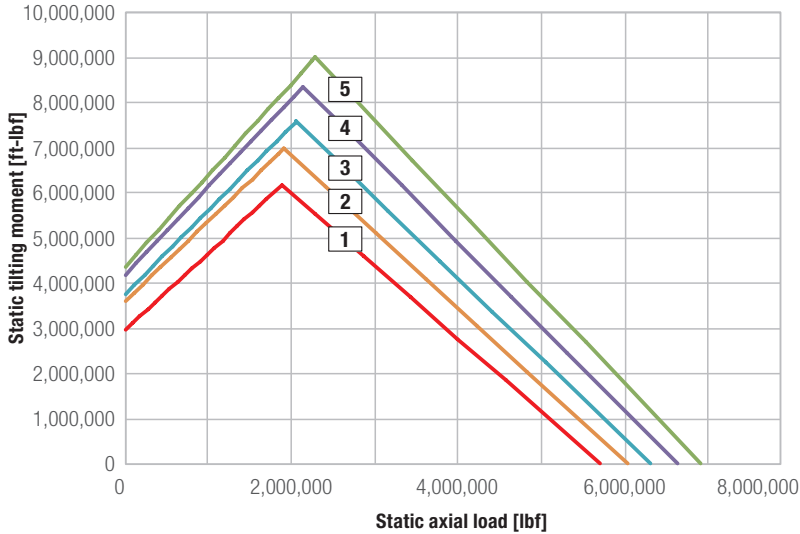

- 1 KUD01947-045W015-900-000
- 2 KUD02047-045W015-900-000
- 3 KUD02147-045W015-900-000
- 4 KUD02247-045W015-900-000
- 5 KUD02347-045W015-900-000

KUD\_W

Bearing type	Bearing data								Bolt data					Gear data							Load rating		
	Weight	Outer diameter	Inner diameter	Total height	Outer diameter Inner ring	Inner diameter Outer ring	Height Outer ring	Height Inner ring	Pitch circle diameter Outer ring	Pitch circle diameter Inner ring	Number of bores per ring	Bolt diameter	Number of grease nipples per level	Pitch circle diameter	Module (metric)	Number of teeth	Profile shift	Tip reduction	Tooth width	Tooth forces (standard)	Tooth forces (maximum)	static	dynamic
	[lbs]	Da [inch]	Di [inch]	H [inch]	O [inch]	U [inch]	H1 [inch]	H2 [inch]	La [inch]	Li [inch]	n	M [mm]	n1	d [inch]	m [mm]	z	x*m [inch]	k*m [inch]	b [inch]	[lbf]	[lbf]	C <sub>stat</sub> [lbf]	C <sub>dyn</sub> [lbf]
1	2,450.8	83.11	70.08	6.69	76.57	76.73	6.22	6.22	80.51	72.68	52	30	8	-	-	-	-	-	-	-	-	5,711,721	394,315
2	2,552.0	87.05	74.02	6.69	80.51	80.67	6.22	6.22	84.45	76.61	60	30	8	-	-	-	-	-	-	-	-	6,034,097	403,082
3	2,690.6	90.98	77.95	6.69	84.45	84.61	6.22	6.22	88.39	80.55	60	30	8	-	-	-	-	-	-	-	-	6,310,387	410,052
4	2,809.4	94.92	81.89	6.69	88.38	88.54	6.22	6.22	92.32	84.49	64	30	9	-	-	-	-	-	-	-	-	6,586,452	415,672
5	2,948.0	98.86	85.83	6.69	92.32	92.48	6.22	6.22	96.26	88.43	64	30	9	-	-	-	-	-	-	-	-	6,908,828	423,540

## No gearing KUD\_50\_WO

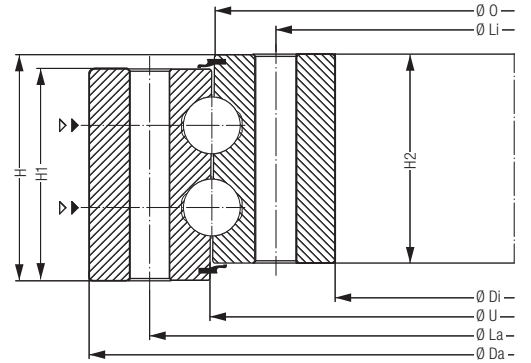
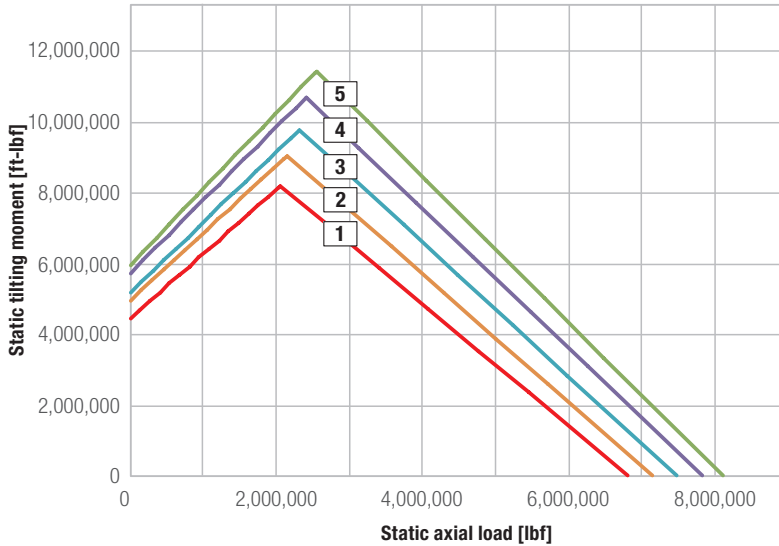

- 1 KUD02097-050W015-900-000
- 2 KUD02197-050W015-900-000
- 3 KUD02297-050W015-900-000
- 4 KUD02397-050W015-900-000
- 5 KUD02497-050W015-900-000

Bearing type	Bearing data								Bolt data					Gear data						Load rating			
	Weight	Outer diameter	Inner diameter	Total height	Outer diameter Inner ring	Inner diameter Outer ring	Height Outer ring	Height Inner ring	Pitch circle diameter Outer ring	Pitch circle diameter Inner ring	Number of bores per ring	Bolt diameter	Number of grease nipples per level	Pitch circle diameter	Module (metric)	Number of teeth	Profile shift	Tip reduction	Tooth width	Tooth forces (standard)	Tooth forces (maximum)	static	dynamic
	[lbs]	Da [inch]	Di [inch]	H [inch]	O [inch]	U [inch]	H1 [inch]	H2 [inch]	La [inch]	Li [inch]	n	M	n1	d [inch]	m [mm]	z	x*m [inch]	k*m [inch]	b [inch]			C <sub>stat</sub> [lbf]	C <sub>dyn</sub> [lbf]
1	3,077.8	89.61	75.39	7.24	82.48	82.64	6.77	6.77	86.77	78.23	60	33	8	-	-	-	-	-	-	-	-	6,824,075	451,192
2	3,218.6	93.54	79.33	7.24	86.42	86.58	6.77	6.77	90.71	82.17	64	33	9	-	-	-	-	-	-	-	-	7,165,111	459,734
3	3,383.6	97.48	83.27	7.24	90.35	90.51	6.77	6.77	94.65	86.10	64	33	9	-	-	-	-	-	-	-	-	7,506,146	468,052
4	3,522.2	101.42	87.20	7.24	94.29	94.45	6.77	6.77	98.58	90.04	68	33	10	-	-	-	-	-	-	-	-	7,847,406	476,145
5	3,687.2	105.35	91.14	7.24	98.23	98.39	6.77	6.77	102.52	93.98	68	33	10	-	-	-	-	-	-	-	-	8,131,564	481,541







# Technical data

## ROD\_D Triple-row roller bearings\*

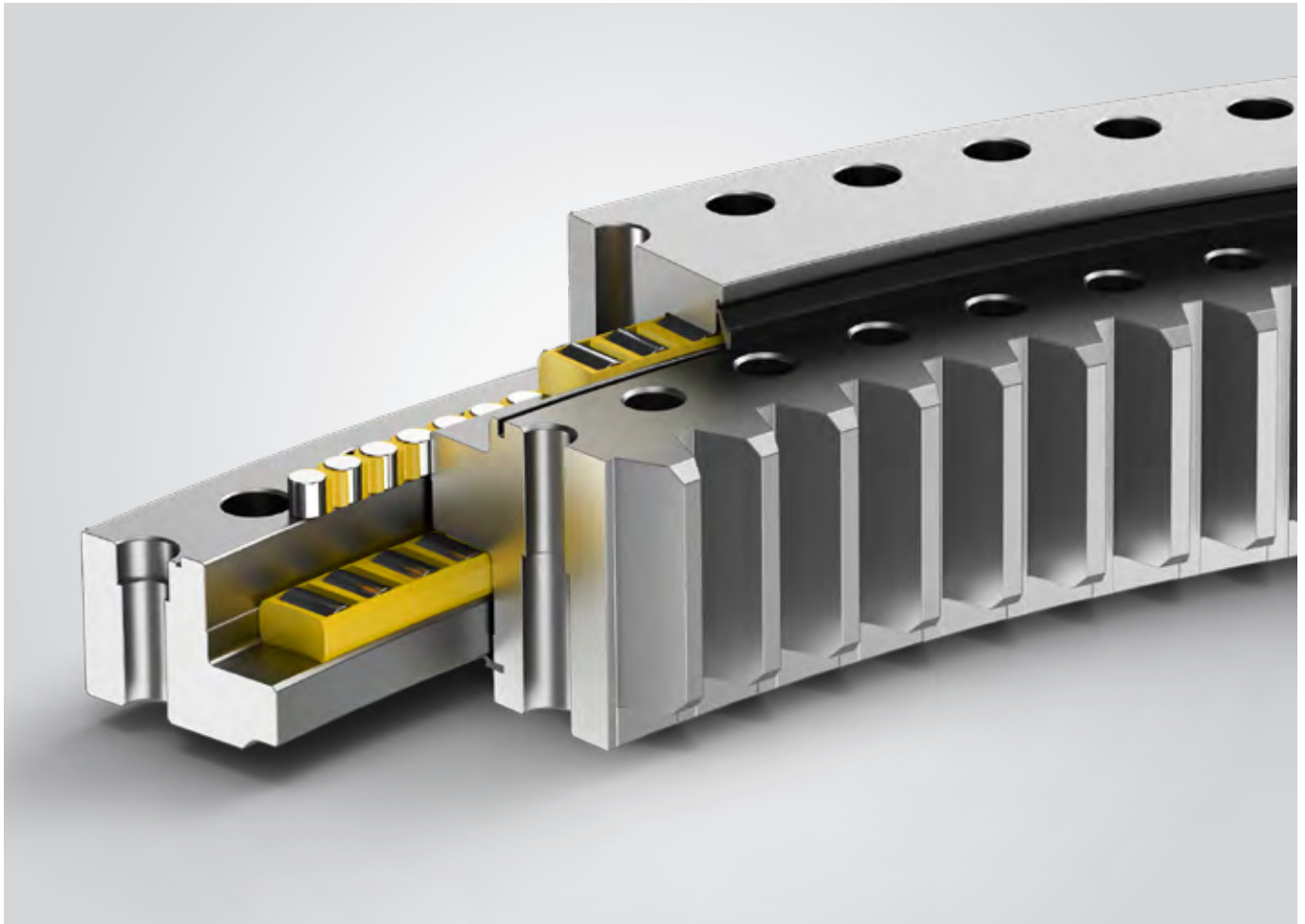

ROD\_D\*

ROD\_DA\*

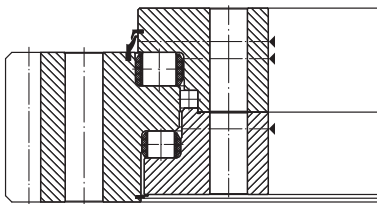

ROD\_DJ\*

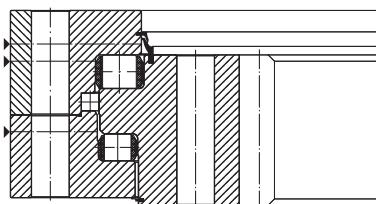

ROD\_D\*

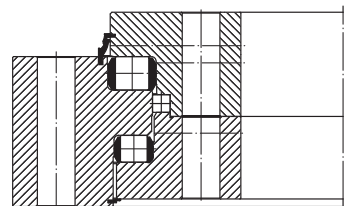
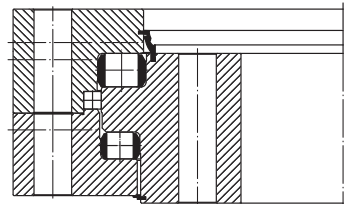

\* Shorter delivery times can be realized.

## External gear ROD\_15/18\_DA\*

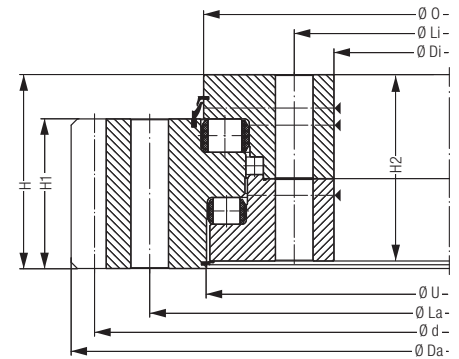
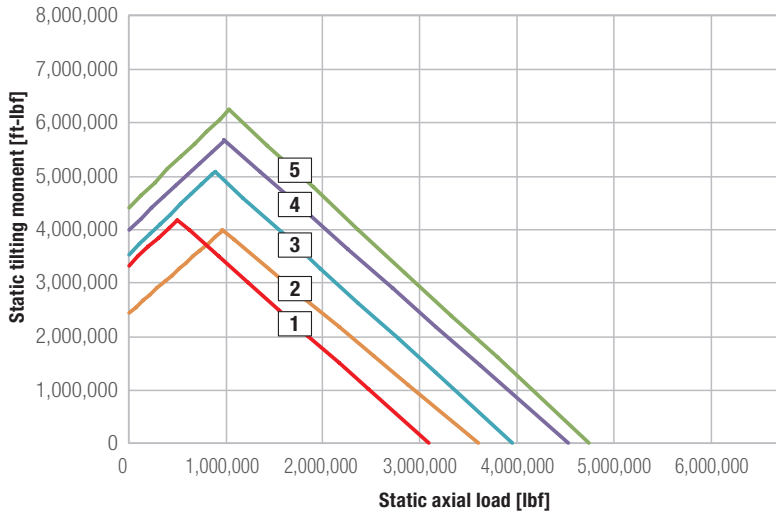

- 1 ROD01847-015DA15-900-000
- 2 ROD02025-015DA15-900-000
- 3 ROD01957-018DA15-900-000
- 4 ROD01972-018DA15-900-000
- 5 ROD02053-018DA15-900-000

Bearing type	Bearing data								Bolt data					Gear data								Load rating	
	Weight	Outer diameter	Inner diameter	Total height	Outer diameter Inner ring	Inner diameter Outer ring	Height Outer ring	Height Inner ring	Pitch circle diameter Outer ring	Pitch circle diameter Inner ring	Number of bores per ring	Bolt diameter	Number of grease nipples per level	Pitch circle diameter	Module (metric)	Number of teeth	Profile shift	Tip reduction	Tooth width	Tooth forces (standard)	Tooth forces (maximum)	static	dynamic
	[lbs]	Da [inch]	Di [inch]	H [inch]	O [inch]	U [inch]	H1 [inch]	H2 [inch]	La [inch]	Li [inch]	n	M [mm]	n1	d [inch]	m [mm]	z	x*m [inch]	k*m [inch]	b [inch]	[lbf]	[lbf]	C <sub>stat</sub> [lbf]	C <sub>dyn</sub> [lbf]
1	1,273.8	80.72	67.09	4.02	73.98	73.43	3.15	3.66	76.97	69.33	72/73	24	4	79.72	9	225	0.177	-0.035	2.953	14,661	29,323	3,598,292	319,004
2	1,456.4	88.46	74.09	4.09	80.98	80.94	3.23	3.82	83.98	76.34	96	24	6	87.09	14	158	0.276	-0.055	3.031	23,415	46,830	3,947,645	334,965
3	1,645.6	85.68	70.55	4.53	78.35	78.15	3.54	4.29	81.54	73.27	72/70	30	6	85.04	9	240	0.000	-0.035	2.953	14,661	29,323	4,562,947	417,695
4	1,548.8	85.68	71.50	4.29	79.25	78.46	3.46	4.09	82.05	73.62	108	22	6	84.69	9	239	0.177	-0.035	3.465	17,203	34,406	4,596,444	307,763
5	1,610.4	89.04	74.80	4.49	81.93	81.93	3.54	4.25	85.28	77.17	90	27	6	87.87	9	248	0.266	-0.035	3.543	17,594	35,187	4,780,113	428,036

\* Shorter delivery times can be realized.

## External gear ROD\_26/32\_DA\*

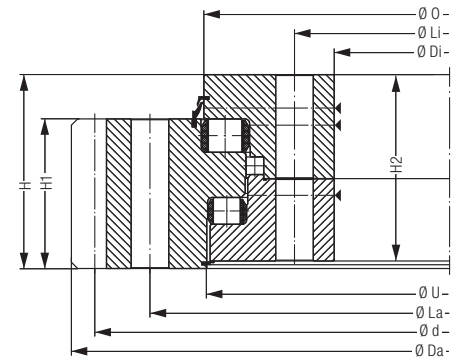
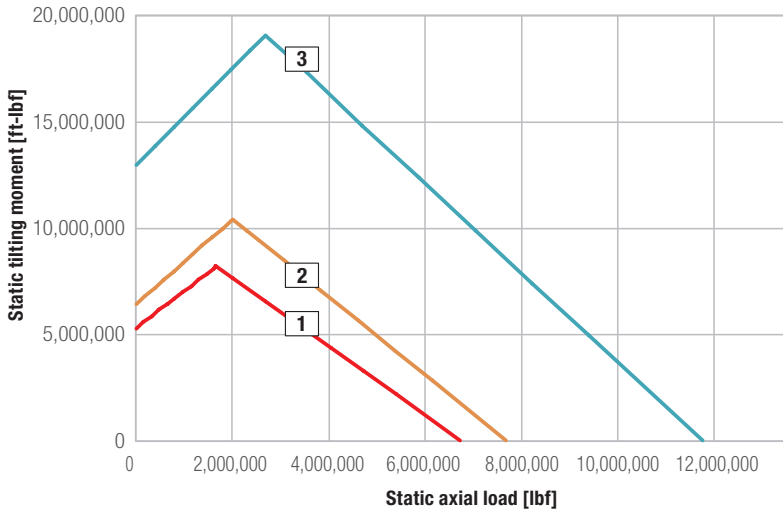

- 1 ROD01986-026DA15-900-000
- 2 ROD02260-026DA15-900-000
- 3 ROD02578-032DA15-900-000

Bearing type	Bearing data								Bolt data					Gear data								Load rating	
	Weight	Outer diameter	Inner diameter	Total height	Outer diameter Inner ring	Inner diameter Outer ring	Height Outer ring	Height Inner ring	Pitch circle diameter Outer ring	Pitch circle diameter Inner ring	Number of bores per ring	Bolt diameter	Number of grease nipples per level	Pitch circle diameter	Module (metric)	Number of teeth	Profile shift	Tip reduction	Tooth width	Tooth forces (standard)	Tooth forces (maximum)	static	dynamic
	[lbs]	Da [inch]	Di [inch]	H [inch]	O [inch]	U [inch]	H1 [inch]	H2 [inch]	La [inch]	Li [inch]	n	M [mm]	n1	d [inch]	m [mm]	z	x*m [inch]	k*m [inch]	b [inch]	[lbf]	[lbf]	C <sub>stat</sub> [lbf]	C <sub>dyn</sub> [lbf]
<b>1</b>	2,886.4	89.57	70.47	6.22	80.12	79.37	4.88	5.98	83.86	73.23	90	30	6	87.56	16	139	0.374	-	4.882	40,939	81,878	6,803,393	695,334
<b>2</b>	3,872.0	100.79	80.55	7.01	90.91	90.16	5.59	6.14	94.65	83.86	80	33	8	99.53	16	158	-	-	5.591	46,882	93,764	7,748,265	744,792
<b>3</b>	6,050.0	116.08	91.73	8.35	103.90	102.91	5.71	8.03	109.29	95.59	84	42	8	113.39	18	160	0.709	-0.071	5.709	53,856	107,713	11,690,739	1,111,455

\* Shorter delivery times can be realized.

## External gear ROD\_40/50\_DA\*

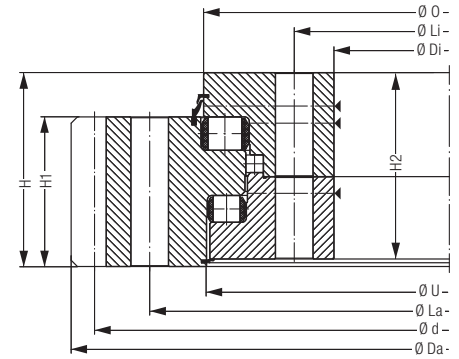
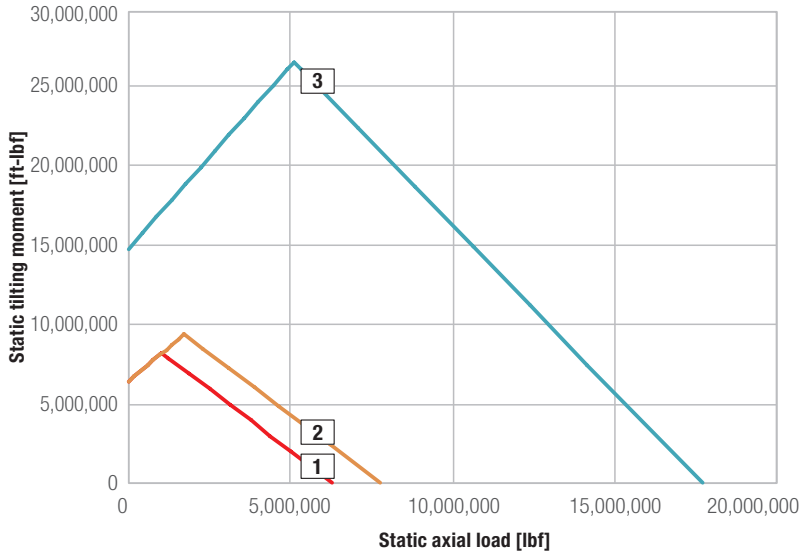

- 1 ROD02547-040DA15-900-000
- 2 ROD01900-040DA15-900-000
- 3 ROD01876-050DA15-900-000

Bearing type	Bearing data								Bolt data					Gear data							Load rating		
	Weight	Outer diameter	Inner diameter	Total height	Outer diameter Inner ring	Inner diameter Outer ring	Height Outer ring	Height Inner ring	Pitch circle diameter Outer ring	Pitch circle diameter Inner ring	Number of bores per ring	Bolt diameter	Number of grease nipples per level	Pitch circle diameter	Module (metric)	Number of teeth	Profile shift	Tip reduction	Tooth width	Tooth forces (standard)	Tooth forces (maximum)	static	dynamic
	[lbs]	Da [inch]	Di [inch]	H [inch]	O [inch]	U [inch]	H1 [inch]	H2 [inch]	La [inch]	Li [inch]	n	M [mm]	n1	d [inch]	m [mm]	z	x*m [inch]	k*m [inch]	b [inch]	[lbf]	[lbf]	C <sub>stat</sub> [lbf]	C <sub>dyn</sub> [lbf]
<b>1</b>	10,370.8	117.92	87.80	10.24	104.09	102.01	8.19	10.04	109.61	92.28	72	48	8	115.51	18	163	0.567	-0.071	7.087	63,337	126,675	17,743,046	1,740,920
<b>2</b>	5,583.6	87.28	64.57	11.02	77.32	76.57	8.54	9.17	80.91	68.31	56	42	8	85.04	15	144	0.591	-0.059	8.543	63,631	127,261	6,295,999	8,38,088
<b>3</b>	6,996.0	87.87	63.39	12.68	76.77	75.79	10.20	10.75	80.91	67.13	56	42	8	85.63	15	145	0.591	-0.059	10.197	75,946	151,893	7,780,413	1,119,549

\* Shorter delivery times can be realized.

## Internal gear ROD\_32\_DJ\*

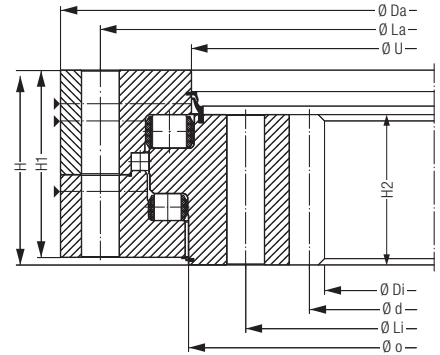
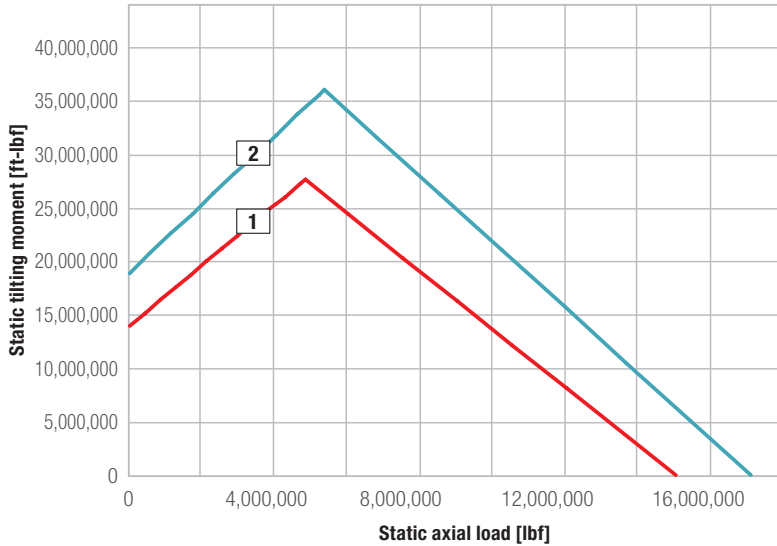

- 1 — ROD03312-032DJ15-900-000
- 2 — ROD03762-032DJ15-900-000

Bearing type	Bearing data								Bolt data					Gear data							Load rating		
	Weight	Outer diameter	Inner diameter	Total height	Outer diameter Inner ring	Inner diameter Outer ring	Height Outer ring	Height Inner ring	Pitch circle diameter Outer ring	Pitch circle diameter Inner ring	Number of bores per ring	Bolt diameter	Number of grease nipples per level	Pitch circle diameter	Module (metric)	Number of teeth	Profile shift	Tip reduction	Tooth width	Tooth forces (standard)	Tooth forces (maximum)	static	dynamic
	[lbs]	Da [inch]	Di [inch]	H [inch]	O [inch]	U [inch]	H1 [inch]	H2 [inch]	La [inch]	Li [inch]	n	M [mm]	n1	d [inch]	m [mm]	z	x*m [inch]	k*m [inch]	b [inch]	[lbf]	[lbf]	C <sub>stat</sub> [lbf]	C <sub>dyn</sub> [lbf]
1	8,063.0	139.76	117.48	8.66	128.66	127.95	8,07	7,09	136.46	124.49	100	36	10	118.11	20	-150	-0.394	-0.079	7.087	70,375	140,750	15,039,493	1,269,721
2	9,240.0	157.48	134.80	8.66	146.38	145.67	8,07	7,09	154.17	142.20	120	36	12	135.43	20	-172	-0.394	-0.079	7.087	70,375	140,750	17,109,759	1,359,644

\* Shorter delivery times can be realized.



# Technical data

## ROD\_D Triple-row roller bearings

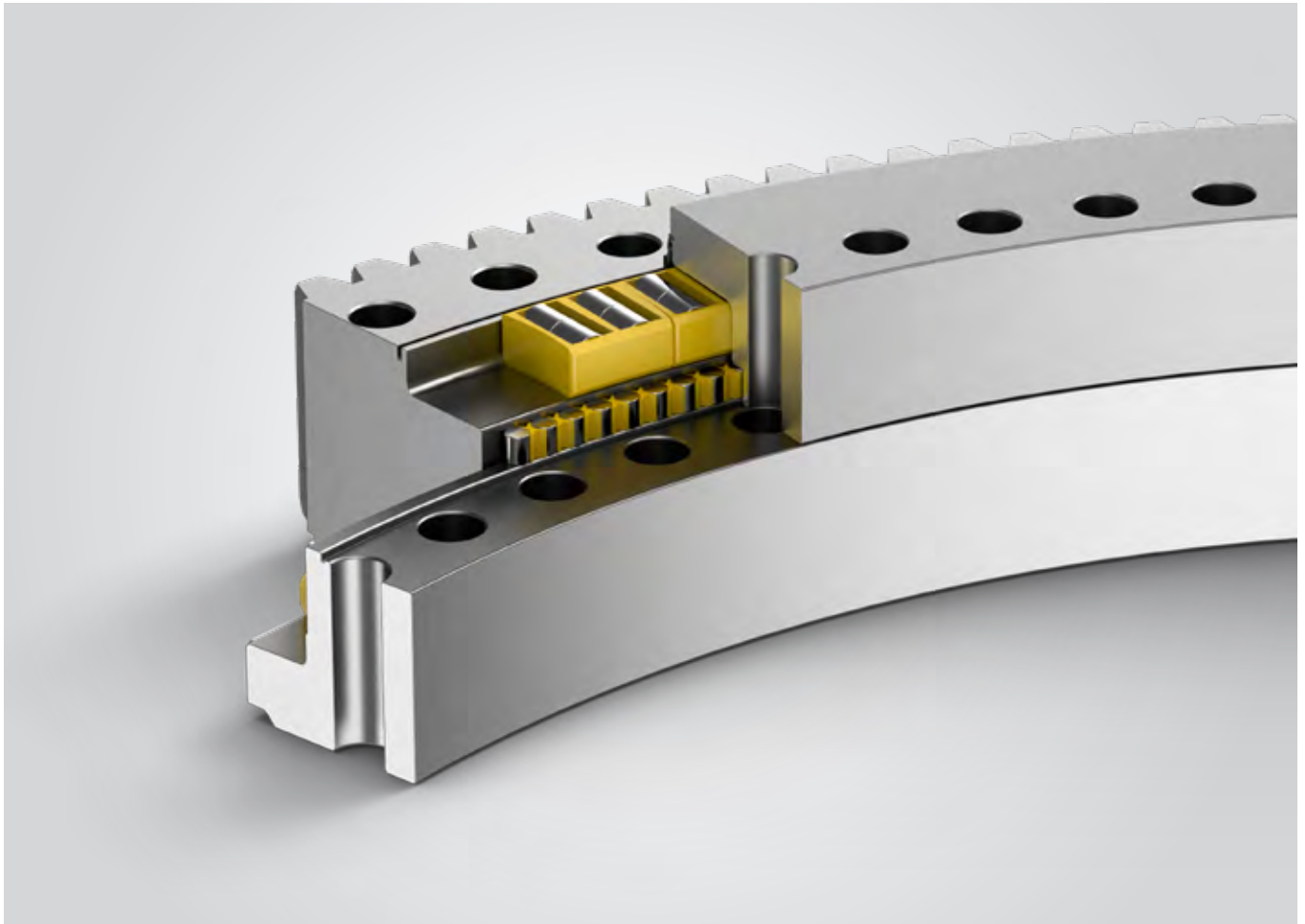

ROD\_DA

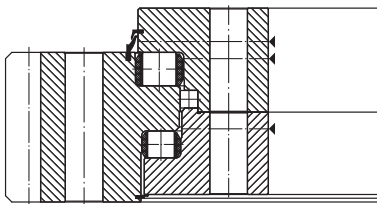

ROD\_DJ

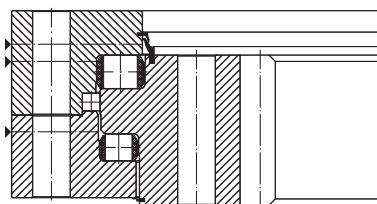

ROD\_DO

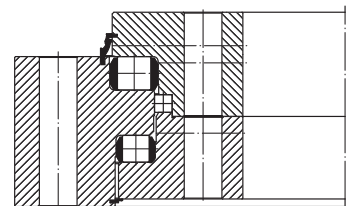
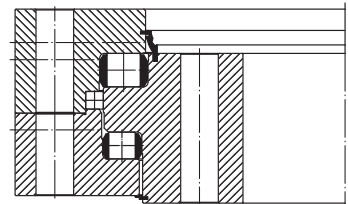

ROD\_D

## External gear ROD\_21\_DA

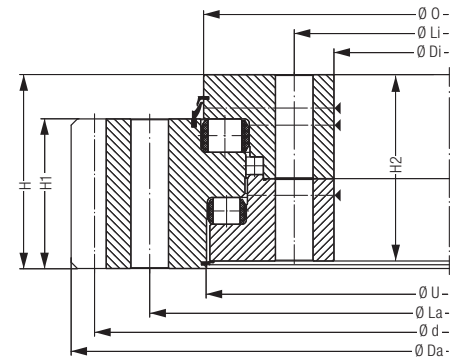
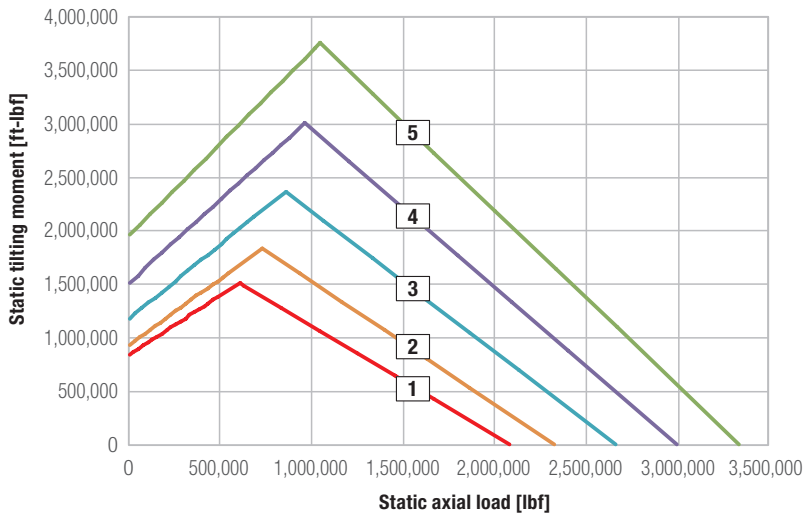

- 1 ROD01250-021DA15-900-000
- 2 ROD01400-021DA15-900-000
- 3 ROD01600-021DA15-900-000
- 4 ROD01800-021DA15-900-000
- 5 ROD02000-021DA15-900-000

Bearing type	Bearing data							Bolt data							Gear data						Load rating		
	Weight	Outer diameter	Inner diameter	Total height	Outer diameter Inner ring	Inner diameter Outer ring	Height Outer ring	Height Inner ring	Pitch circle diameter Outer ring	Pitch circle diameter Inner ring	Number of bores per ring	Bolt diameter	Number of grease nipples per level	Pitch circle diameter	Module (metric)	Number of teeth	Profile shift	Tip reduction	Tooth width	Tooth forces (standard)	Tooth forces (maximum)	static	dynamic
	[lbs]	Da [inch]	Di [inch]	H [inch]	O [inch]	U [inch]	H1 [inch]	H2 [inch]	La [inch]	Li [inch]	n	M	n1	d [inch]	m [mm]	z	x*m [inch]	k*m [inch]	b [inch]	[lbf]	[lbf]	C <sub>stat</sub> [lbf]	C <sub>dyn</sub> [lbf]
1	1,192.4	57.54	43.43	5.20	50.47	50.39	4.17	4.84	53.35	45.47	36	24	3	56.22	12	119	0.236	-0.047	4.173	26,235	52,470	2,086,677	277,414
2	1,421.2	64.38	49.33	5.20	56.38	56.30	4.17	4.84	59.25	51.38	36	24	3	62.83	14	114	0.276	-0.055	4.173	30,619	61,238	2,332,393	294,050
3	1,608.2	72.09	57.20	5.20	64.25	64.17	4.17	4.84	67.13	59.25	40	24	4	70.55	14	128	0.276	-0.055	4.173	30,619	61,238	2,445,022	315,857
4	1,856.8	80.50	65.08	5.20	72.13	72.05	4.17	4.84	75.00	67.13	46	24	5	78.74	16	125	0.315	-0.063	4.173	35,025	69,961	3,007,494	336,314
5	2,006.4	88.06	72.95	5.20	80.00	79.92	4.17	4.84	82.87	75.00	54	24	5	86.30	16	137	0.315	-0.063	4.173	35,025	69,961	3,344,932	355,873



## External gear ROD\_26\_DA

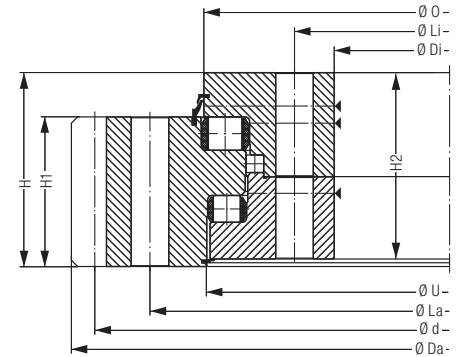
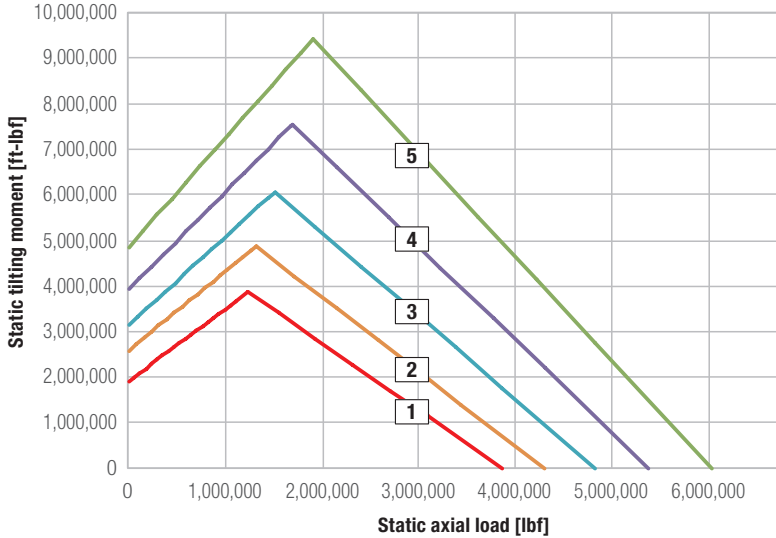

- 1 ROD01800-026DA15-900-000
- 2 ROD02000-026DA15-900-000
- 3 ROD02240-026DA15-900-000
- 4 ROD02500-026DA15-900-000
- 5 ROD02800-026DA15-900-000

Bearing type	Bearing data								Bolt data							Gear data						Load rating	
	Weight	Outer diameter	Inner diameter	Total height	Outer diameter	Inner diameter	Height	Height	Pitch circle diameter	Pitch circle diameter	Number of bores per ring	Bolt diameter	Number of grease nipples per level	Pitch circle diameter	Module (metric)	Number of teeth	Profile shift	Tip reduction	Tooth width	Tooth forces (standard)	Tooth forces (maximum)	static	dynamic
	[lbs]	Da [inch]	Di [inch]	H [inch]	O [inch]	U [inch]	H1 [inch]	H2 [inch]	La [inch]	Li [inch]	n	M	n1	d [inch]	m [mm]	z	x*m [inch]	k*m [inch]	b [inch]	[lbf]	[lbf]	C <sub>stat</sub> [lbf]	C <sub>dyn</sub> [lbf]
1	2,477.2	81.76	63.74	5.79	72.28	71.89	4.61	5.43	75.79	66.34	36	30	6	80.00	16	127	0.315	-0.063	4.606	36,576	73,153	3,855,024	458,385
2	2,675.2	89.32	71.61	5.79	80.16	79.76	4.61	5.43	83.66	74.21	44	30	7	87.56	16	139	0.315	-0.063	4.606	36,576	73,153	4,285,983	484,688
3	3,031.6	99.07	81.06	5.79	89.61	89.21	4.61	5.43	93.15	83.66	48	30	8	97.09	18	137	0.354	-0.071	4.606	41,163	82,325	4,812,935	515,712
4	3,447.4	109.70	91.30	5.79	99.84	99.45	4.61	5.43	103.35	93.90	54	30	6	107.72	18	152	0.354	-0.071	4.606	41,163	82,325	5,363,492	545,836
5	3,927.0	121.89	103.11	5.79	111.65	111.26	4.61	5.43	115.16	105.71	60	30	10	119.69	20	152	0.394	-0.079	4.606	45,726	91,452	6,010,042	579,557

ROD\_D

## External gear ROD\_32\_DA

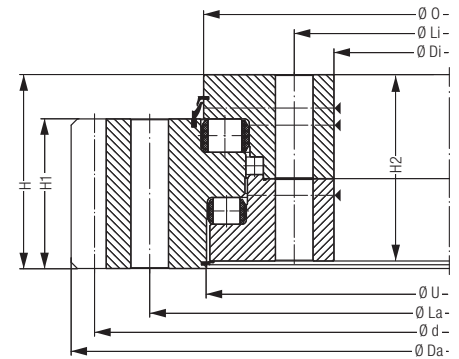
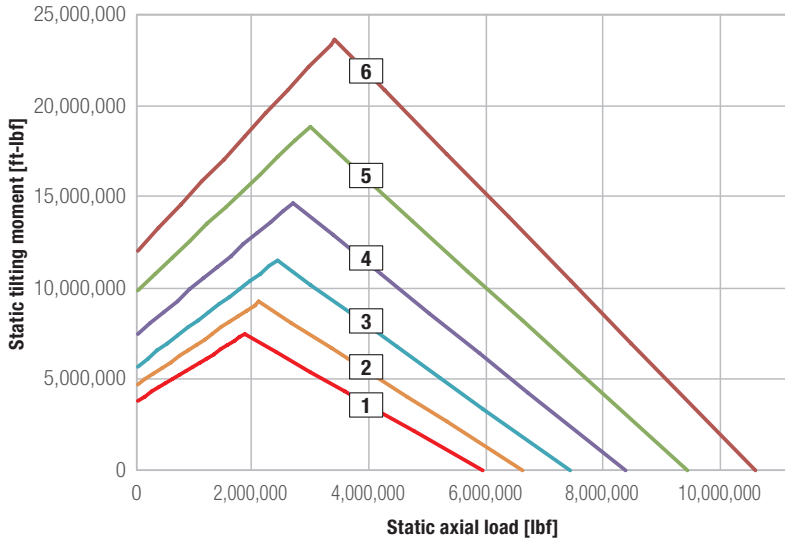

- 1 ROD02240-032DA15-900-000
- 2 ROD02500-032DA15-900-000
- 3 ROD02800-032DA15-900-000
- 4 ROD03150-032DA15-900-000
- 5 ROD03550-032DA15-900-000
- 6 ROD04000-032DA15-900-000

Bearing type	Bearing data									Bolt data					Gear data							Load rating	
	Weight	Outer diameter	Inner diameter	Total height	Outer diameter Inner ring	Inner diameter Outer ring	Height Outer ring	Height Inner ring	Pitch circle diameter Outer ring	Pitch circle diameter Inner ring	Number of bores per ring	Bolt diameter	Number of grease nipples per level	Pitch circle diameter	Module (metric)	Number of teeth	Profile shift	Tip reduction	Tooth width	Tooth forces (standard)	Tooth forces (maximum)	static	dynamic
	[lbs]	Da [inch]	Di [inch]	H [inch]	O [inch]	U [inch]	H1 [inch]	H2 [inch]	La [inch]	Li [inch]	n	M	n1	d [inch]	m [mm]	z	x*m [inch]	k*m [inch]	b [inch]	[lbf]	[lbf]	C <sub>stat</sub> [lbf]	C <sub>dyn</sub> [lbf]
1	4,345.0	100.49	79.61	7.13	89.80	89.37	5.47	6.77	94.29	82.68	40	36	8	98.50	18	139	0.354	-0.071	5.472	48,918	97,837	5,918,320	678,473
2	4,972.0	111.12	89.84	7.13	100.04	99.61	5.47	6.77	104.53	92.91	44	36	7	109.13	18	154	0.354	-0.071	5.472	48,918	97,837	6,612,530	719,613
3	5,667.2	123.46	101.65	7.13	111.85	111.42	5.47	6.77	116.34	104.72	48	36	8	121.26	20	154	0.394	-0.079	5.472	54,336	108,673	7,416,222	764,800
4	6,221.6	136.85	115.43	7.13	125.63	125.20	5.47	6.77	130.12	118.50	56	36	7	134.65	20	171	0.394	-0.079	5.472	54,336	108,673	8,366,040	815,382
5	7,147.8	153.13	131.18	7.13	141.38	140.94	5.47	6.77	145.87	134.25	66	36	8	150.71	22	174	0.433	-0.087	5.472	59,777	119,553	9,425,565	868,437
6	8,254.4	171.32	148.90	7.13	159.09	158.66	5.47	6.77	163.58	151.97	72	36	9	168.90	22	195	0.433	-0.087	5.472	59,777	119,553	10,594,571	923,066

## External gear ROD\_40\_DA

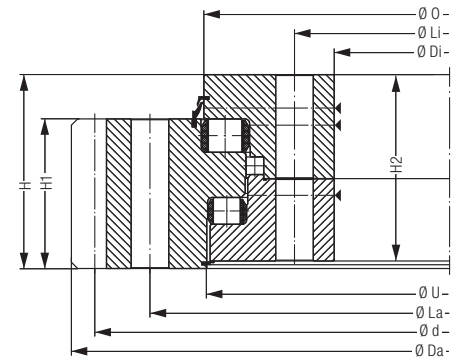
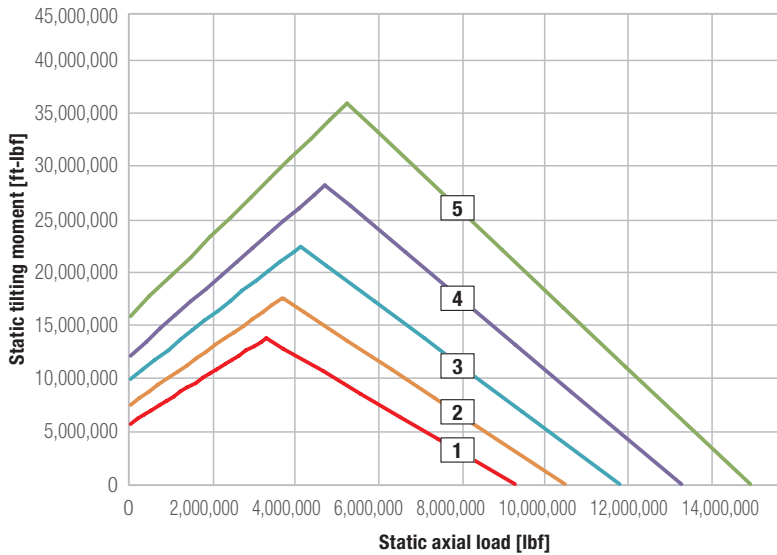

- 1 ROD02800-040DA15-900-000
- 2 ROD03150-040DA15-900-000
- 3 ROD03550-040DA15-900-000
- 4 ROD04000-040DA15-900-000
- 5 ROD04500-040DA15-900-000

Bearing type	Bearing data								Bolt data						Gear data						Load rating		
	Weight	Outer diameter	Inner diameter	Total height	Outer diameter	Inner diameter	Height	Height	Pitch circle diameter	Pitch circle diameter	Number of bores per ring	Bolt diameter	Number of grease nipples per level	Pitch circle diameter	Module (metric)	Number of teeth	Profile shift	Tip reduction	Tooth width	Tooth forces (standard)	Tooth forces (maximum)	static	dynamic
	[lbs]	Da [inch]	Di [inch]	H [inch]	O [inch]	U [inch]	H1 [inch]	H2 [inch]	La [inch]	Li [inch]	n	M	n1	d [inch]	m [mm]	z	x*m [inch]	k*m [inch]	b [inch]	[lbf]	[lbf]	C <sub>stat</sub> [lbf]	C <sub>dyn</sub> [lbf]
1	7,187.4	123.46	100.87	8.66	112.20	111.69	6.69	8.27	116.73	103.94	48	36	8	121.26	20	154	0.394	-0.079	6.693	66,476	132,952	9,272,245	1,068,292
2	8,386.4	138.41	114.65	8.66	125.98	125.47	6.69	8.27	130.51	117.72	56	36	7	135.98	22	157	0.433	-0.087	6.693	73,108	146,216	10,474,073	1,097,068
3	9,361.0	154.00	130.39	8.66	141.73	141.22	6.69	8.27	146.26	133.46	66	36	8	151.57	22	175	0.433	-0.087	6.693	73,108	146,216	11,790,555	1,167,433
4	10,571.0	171.78	148.11	8.66	159.45	158.94	6.69	8.27	163.98	151.18	72	36	9	169.13	24	179	0.472	-0.094	6.693	79,762	159,524	13,278,565	1,242,969
5	11,902.0	191.62	167.80	8.66	179.13	178.62	6.69	8.27	183.66	170.87	84	36	14	188.98	24	200	0.472	-0.094	6.693	79,762	159,524	14,938,554	1,322,776

## External gear ROD\_50\_DA

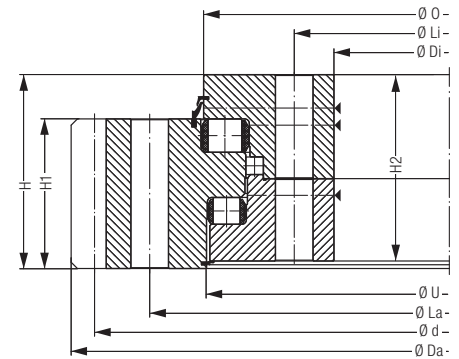
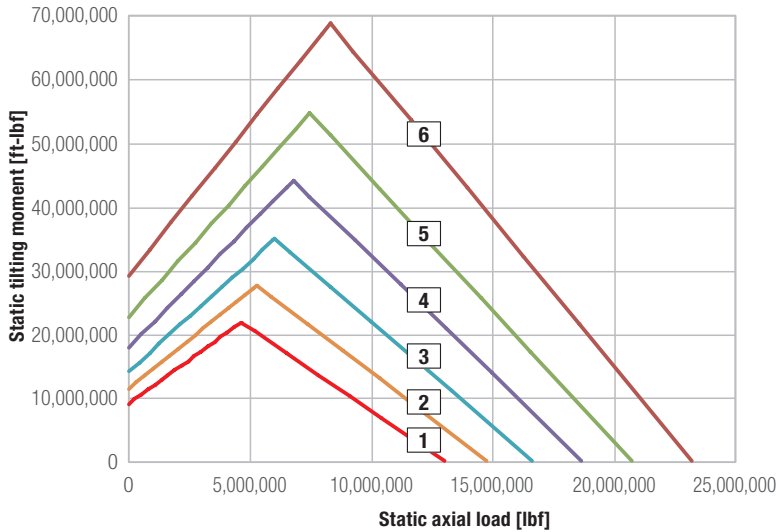

- 1 ROD03150-050DA15-900-000
- 2 ROD03550-050DA15-900-000
- 3 ROD04000-050DA15-900-000
- 4 ROD04500-050DA15-900-000
- 5 ROD05000-050DA15-900-000
- 6 ROD05600-050DA15-900-000

Bearing type	Bearing data								Bolt data						Gear data						Load rating		
	Weight	Outer diameter	Inner diameter	Total height	Outer diameter Inner ring	Inner diameter Outer ring	Height Outer ring	Height Inner ring	Pitch circle diameter Outer ring	Pitch circle diameter Inner ring	Number of bores per ring	Bolt diameter	Number of grease nipples per level	Pitch circle diameter	Module (metric)	Number of teeth	Profile shift	Tip reduction	Tooth width	Tooth forces (standard)	Tooth forces (maximum)	static	dynamic
	[lbs]	Da [inch]	Di [inch]	H [inch]	O [inch]	U [inch]	H1 [inch]	H2 [inch]	La [inch]	Li [inch]	n	M [mm]	n1	d [inch]	m [mm]	z	x*m [inch]	k*m [inch]	b [inch]	[lbf]	[lbf]	C <sub>stat</sub> [lbf]	C <sub>dyn</sub> [lbf]
1	11,655.6	140.60	113.58	10.55	126.38	125.83	7.99	10.16	131.89	117.13	48	42	8	137.95	24	146	0.472	-0.094	7.992	95,229	190,458	13,056,903	1,471,150
2	12,826.0	155.72	129.33	10.55	142.13	141.57	7.99	10.16	147.64	132.87	54	42	9	153.07	24	162	0.472	-0.094	7.992	95,229	190,458	14,756,009	1,570,290
3	14,471.6	173.67	147.05	10.55	159.84	159.29	7.99	10.16	165.35	150.59	60	42	10	171.02	24	181	0.472	-0.094	7.992	95,229	190,458	16,634,063	1,673,028
4	16,403.2	193.51	166.73	10.55	179.53	178.98	7.99	10.16	185.04	170.28	68	42	11	190.87	24	202	0.472	-0.094	7.992	95,229	190,458	18,691,065	1,778,688
5	18,169.8	213.35	186.42	10.55	199.21	198.66	7.99	10.16	204.72	189.96	78	42	13	209.76	24	222	0.472	-0.094	7.992	95,229	190,458	20,747,842	1,878,953
6	20,785.6	236.98	210.04	10.55	222.83	222.28	7.99	10.16	228.35	213.58	90	42	15	234.33	24	248	0.472	-0.094	7.992	95,229	190,458	23,251,989	1,995,629

## Internal gear ROD\_21\_DJ

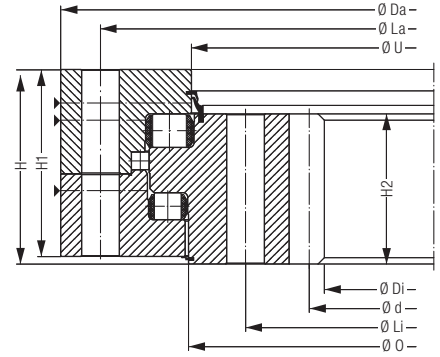
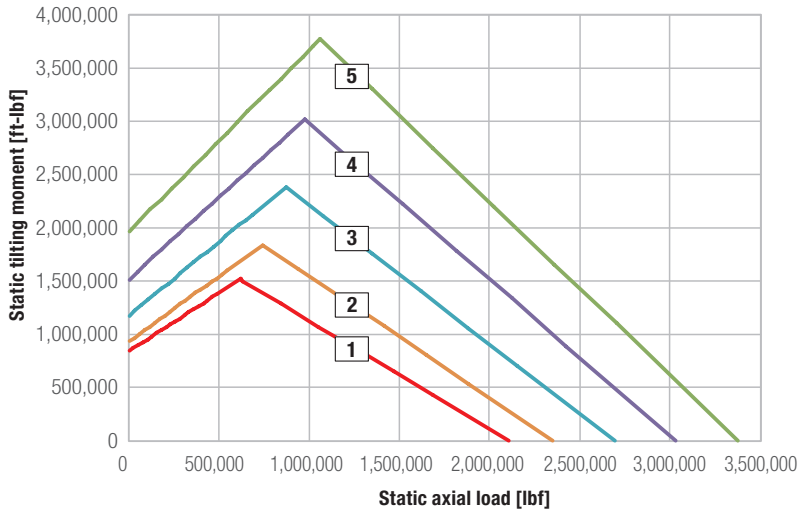

- 1 ROD01250-021DJ15-900-000
- 2 ROD01400-021DJ15-900-000
- 3 ROD01600-021DJ15-900-000
- 4 ROD01800-021DJ15-900-000
- 5 ROD02000-021DJ15-900-000

Bearing type	Bearing data								Bolt data						Gear data						Load rating		
	Weight	Outer diameter	Inner diameter	Total height	Outer diameter Inner ring	Inner diameter Outer ring	Height Outer ring	Height Inner ring	Pitch circle diameter Outer ring	Pitch circle diameter Inner ring	Number of bores per ring	Bolt diameter	Number of grease nipples per level	Pitch circle diameter	Module (metric)	Number of teeth	Profile shift	Tip reduction	Tooth width	Tooth forces (standard)	Tooth forces (maximum)	static	dynamic
	[lbs]	Da [inch]	Di [inch]	H [inch]	O [inch]	U [inch]	H1 [inch]	H2 [inch]	La [inch]	Li [inch]	n	M	n1	d [inch]	m [mm]	z	x*m	k*m	b [inch]	[lbf]	[lbf]	C <sub>stat</sub> [lbf]	C <sub>dyn</sub> [lbf]
1	1,185.8	55.00	40.63	5.20	47.99	47.95	4.84	4.17	52.95	45.08	36	24	3	41.10	12	-87	-0.236	-	4.173	26,235	52,470	2,086,677	277,414
2	1,386.0	60.91	45.75	5.20	53.90	53.86	4.84	4.17	58.86	50.98	36	24	3	46.30	14	-84	-0.276	-	4.173	30,619	61,238	2,332,393	294,050
3	1,551.0	68.78	54.02	5.20	61.77	61.73	4.84	4.17	66.73	58.86	40	24	4	54.57	14	-99	-0.276	-	4.173	30,619	61,238	2,445,022	315,857
4	1,823.8	76.65	61.10	5.20	69.65	69.61	4.84	4.17	74.61	66.73	46	24	5	61.73	16	-98	-0.315	-	4.173	35,025	69,961	3,007,494	336,314
5	1,984.4	84.53	69.29	5.20	77.52	77.48	4.84	4.17	82.48	74.61	54	24	5	69.92	16	-111	-0.315	-	4.173	35,025	69,961	3,344,932	355,873

ROD\_D

## Internal gear ROD\_26\_DJ

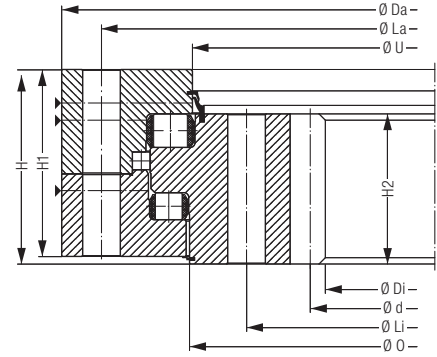
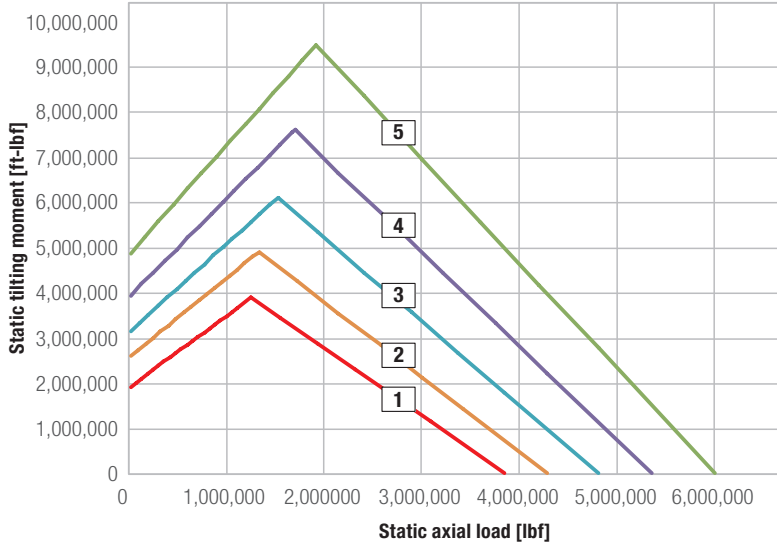

- 1 ROD01800-026DJ15-900-000
- 2 ROD02000-026DJ15-900-000
- 3 ROD02240-026DJ15-900-000
- 4 ROD02500-026DJ15-900-000
- 5 ROD02800-026DJ15-900-000

Bearing type	Bearing data								Bolt data						Gear data						Load rating		
	Weight	Outer diameter	Inner diameter	Total height	Outer diameter Inner ring	Inner diameter Outer ring	Height Outer ring	Height Inner ring	Pitch circle diameter Outer ring	Pitch circle diameter Inner ring	Number of bores per ring	Bolt diameter	Number of grease nipples per level	Pitch circle diameter	Module (metric)	Number of teeth	Profile shift	Tip reduction	Tooth width	Tooth forces (standard)	Tooth forces (maximum)	static	dynamic
	[lbs]	Da [inch]	Di [inch]	H [inch]	O [inch]	U [inch]	H1 [inch]	H2 [inch]	La [inch]	Li [inch]	n	M	n1	d [inch]	m [mm]	z	x*m [inch]	k*m [inch]	b [inch]	[lbf]	[lbf]	C <sub>stat</sub> [lbf]	C <sub>dyn</sub> [lbf]
1	2422.2	77.99	59.84	5.79	69.84	69.41	5.43	4.61	75.39	65.94	36	30	6	60.47	16	-96	-0.315	-	4.606	36576	73153	3855024	458385
2	2644.4	85.87	68.03	5.79	77.72	77.28	5.43	4.61	83.27	73.82	44	30	7	68.66	16	-109	-0.315	-	4.606	36576	73153	4285983	484688
3	3093.2	95.31	76.54	5.79	87.17	86.73	5.43	4.61	92.72	83.27	48	30	8	77.24	18	-109	-0.354	-	4.606	41163	82325	4812935	515712
4	3399.0	105.55	87.17	5.79	97.40	96.97	5.43	4.61	102.95	93.50	54	30	6	87.87	18	-124	-0.354	-	4.606	41163	82325	5363492	545836
5	3887.4	117.36	98.43	5.79	109.21	108.78	5.43	4.61	114.76	105.31	60	30	10	99.21	20	-126	-0.394	-	4.606	45726	91452	6010042	579557

## Internal gear ROD\_32\_DJ

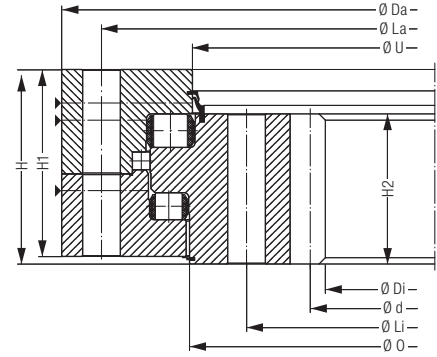
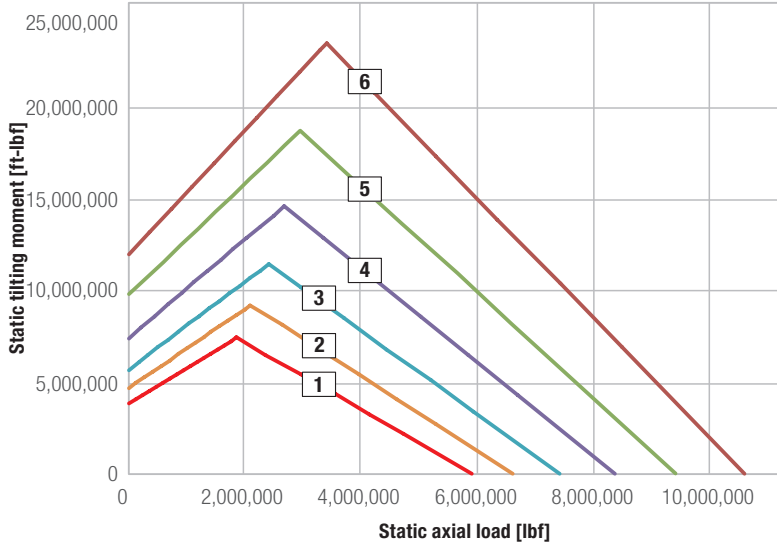

- 1 ROD02240-032DJ15-900-000
- 2 ROD02500-032DJ15-900-000
- 3 ROD02800-032DJ15-900-000
- 4 ROD03150-032DJ15-900-000
- 5 ROD03550-032DJ15-900-000
- 6 ROD04000-032DJ15-900-000

Bearing type	Bearing data								Bolt data						Gear data						Load rating		
	Weight	Outer diameter	Inner diameter	Total height	Outer diameter Inner ring	Inner diameter Outer ring	Height Outer ring	Height Inner ring	Pitch circle diameter Outer ring	Pitch circle diameter Inner ring	Number of bores per ring	Bolt diameter	Number of grease nipples per level	Pitch circle diameter	Module (metric)	Number of teeth	Profile shift	Tip reduction	Tooth width	Tooth forces (standard)	Tooth forces (maximum)	static	dynamic
	[lbs]	Da [inch]	Di [inch]	H [inch]	O [inch]	U [inch]	H1 [inch]	H2 [inch]	La [inch]	Li [inch]	n	M	n1	d [inch]	m [mm]	z	x*m [inch]	k*m [inch]	b [inch]	[lbf]	[lbf]	C <sub>stat</sub> [lbf]	C <sub>dyn</sub> [lbf]
1	4,356.0	96.77	75.12	7.13	87.01	86.57	6.77	5.47	93.70	82.09	40	36	8	75.79	18	-107	-0.354	-	5.472	48,918	97,837	5,918,320	678,473
2	4,862.0	107.01	85.75	7.13	109.06	96.81	6.77	5.47	103.94	92.32	44	36	7	86.46	18	-122	-0.354	-	5.472	48,918	97,837	6,612,530	719,613
3	5,592.4	118.82	96.85	7.13	109.06	108.62	6.77	5.47	115.75	104.13	48	36	8	97.64	20	-124	-0.394	-	5.472	54,336	108,673	7,416,222	764,800
4	6,175.4	132.60	111.02	7.13	122.83	122.40	6.77	5.47	129.53	117.91	56	36	7	111.81	20	-142	-0.394	-	5.472	54,336	108,673	8,366,040	815,382
5	7,264.4	152.28	125.59	7.13	138.58	138.15	6.77	5.47	145.28	133.66	66	36	8	126.46	22	-146	-0.433	-	5.472	59,777	119,553	9,425,565	868,437
6	8,060.8	166.06	143.78	7.13	156.30	155.87	6.77	5.47	162.99	151.38	72	36	9	144.65	22	-167	-0.433	-	5.472	59,777	119,553	10,594,571	923,066

## Internal gear ROD\_40\_DJ

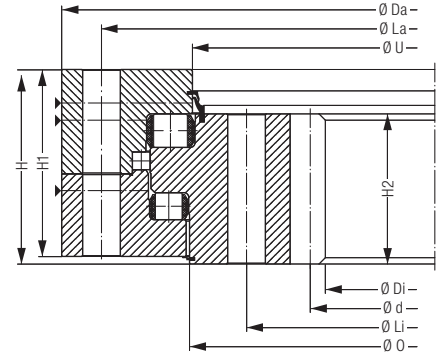
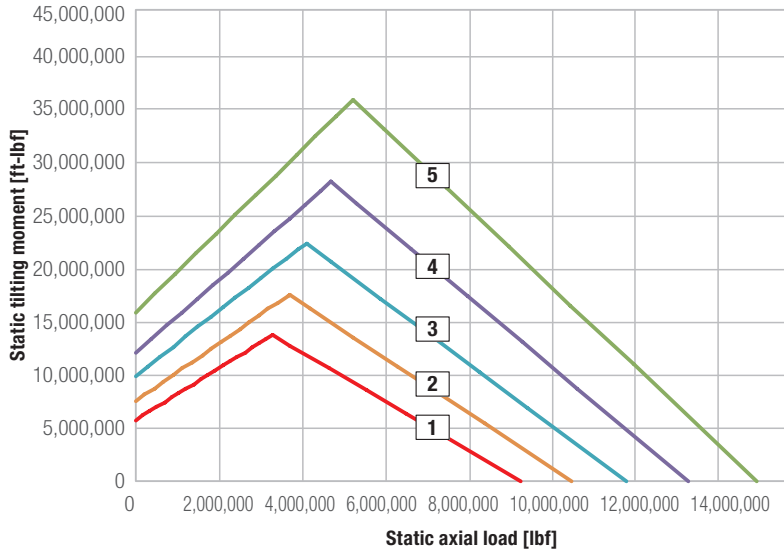

- 1 ROD02800-040DJ15-900-000
- 2 ROD03150-040DJ15-900-000
- 3 ROD03550-040DJ15-900-000
- 4 ROD04000-040DJ15-900-000
- 5 ROD04500-040DJ15-900-000

Bearing type	Bearing data								Bolt data						Gear data						Load rating		
	Weight	Outer diameter	Inner diameter	Total height	Outer diameter Inner ring	Inner diameter Outer ring	Height Outer ring	Height Inner ring	Pitch circle diameter Outer ring	Pitch circle diameter Inner ring	Number of bores per ring	Bolt diameter	Number of grease nipples per level	Pitch circle diameter	Module (metric)	Number of teeth	Profile shift	Tip reduction	Tooth width	Tooth forces (standard)	Tooth forces (maximum)	static	dynamic
	[lbs]	Da [inch]	Di [inch]	H [inch]	O [inch]	U [inch]	H1 [inch]	H2 [inch]	La [inch]	Li [inch]	n	M	n1	d [inch]	m [mm]	z	x*m [inch]	k*m [inch]	b [inch]	[lbf]	[lbf]	C <sub>stat</sub> [lbf]	C <sub>dyn</sub> [lbf]
1	7,068.6	119.61	96.85	8.66	108.78	108.27	8.27	6.69	116.54	103.74	48	36	8	97.64	20	-124	-0.394	-	6.693	66,476	132,952	9,272,245	1,068,292
2	8,102.6	133.39	110.00	8.66	122.56	122.05	8.27	6.69	130.31	117.52	56	36	7	110.87	22	-128	-0.433	-	6.693	73,108	146,216	10,474,073	1,097,068
3	9,176.2	149.13	125.59	8.66	138.31	137.80	8.27	6.69	146.06	133.27	66	36	8	126.46	22	-146	-0.433	-	6.693	73,108	146,216	11,790,555	1,167,433
4	7,068.6	166.85	142.68	8.66	156.02	155.51	8.27	6.69	163.78	150.98	72	36	9	143.62	24	-152	-0.472	-	6.693	79,762	159,524	13,278,565	1,242,969
5	8,102.6	186.54	162.52	8.66	175.71	175.20	8.27	6.69	183.46	170.67	84	36	14	163.46	24	-173	-0.472	-	6.693	79,762	159,524	14,938,554	1,322,776



## Internal gear ROD\_50\_DJ

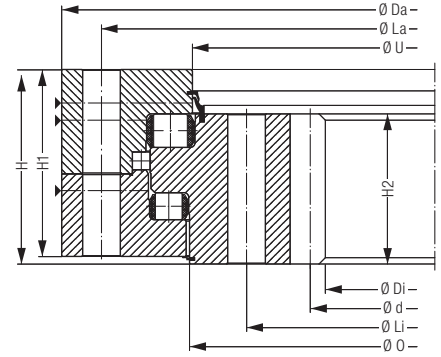
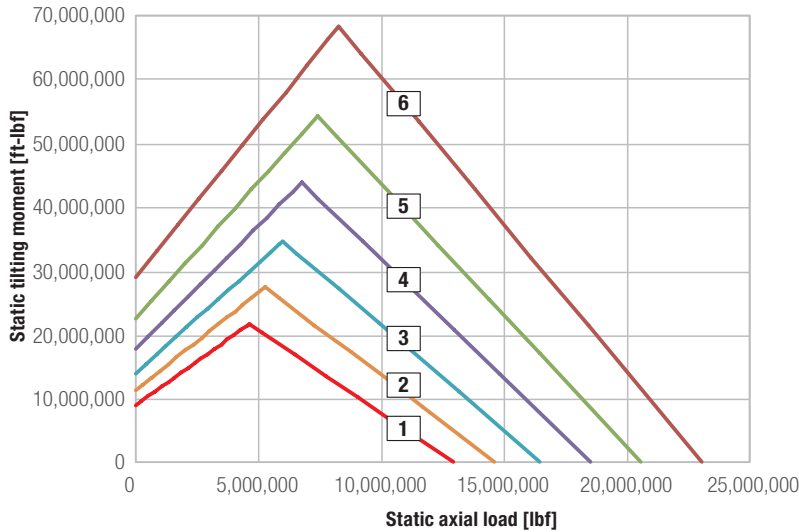

- 1 ROD03150-050DJ15-900-000
- 2 ROD03550-050DJ15-900-000
- 3 ROD04000-050DJ15-900-000
- 4 ROD04500-050DJ15-900-000
- 5 ROD05000-050DJ15-900-000
- 6 ROD05600-050DJ15-900-000

Bearing type	Bearing data								Bolt data						Gear data						Load rating		
	Weight	Outer diameter	Inner diameter	Total height	Outer diameter Inner ring	Inner diameter Outer ring	Height Outer ring	Height Inner ring	Pitch circle diameter Outer ring	Pitch circle diameter Inner ring	Number of bores per ring	Bolt diameter	Number of grease nipples per level	Pitch circle diameter	Module (metric)	Number of teeth	Profile shift	Tip reduction	Tooth width	Tooth forces (standard)	Tooth forces (maximum)	static	dynamic
	[lbs]	Da [inch]	Di [inch]	H [inch]	O [inch]	U [inch]	H1 [inch]	H2 [inch]	La [inch]	Li [inch]	n	M	n1	d [inch]	m [mm]	z	x*m	k*m	b [inch]	[lbf]	[lbf]	C <sub>stat</sub> [lbf]	C <sub>dyn</sub> [lbf]
1	11,281.6	134.45	107.72	10.55	122.20	121.65	10.16	7.99	130.91	116.14	48	42	8	108.66	24	-115	-0.472	-	7.992	95,229	190,458	13,056,903	1,471,150
2	13,015.2	150.20	122.83	10.55	137.95	137.40	10.16	7.99	146.65	131.89	54	42	9	123.78	24	-131	-0.472	-	7.992	95,229	190,458	14,756,009	1,570,290
3	14,570.6	167.91	140.79	10.55	155.67	155.12	10.16	7.99	164.37	149.61	60	42	10	141.73	24	-150	-0.472	-	7.992	95,229	190,458	16,634,063	1,673,028
4	16,339.4	187.60	160.63	10.55	175.35	174.80	10.16	7.99	184.06	169.29	68	42	11	161.57	24	-171	-0.472	-	7.992	95,229	190,458	18,691,065	1,778,688
5	18,000.4	207.28	180.47	10.55	195.04	194.49	10.16	7.99	203.74	188.98	78	42	13	181.42	24	-192	-0.472	-	7.992	95,229	190,458	20,747,842	1,878,953
6	20,497.4	230.91	204.09	10.55	218.66	218.11	10.16	7.99	227.36	212.60	90	42	15	205.04	24	-217	-0.472	-	7.992	95,229	190,458	23,251,989	1,995,629



# Technical data

## RKD Combined roller and ball bearings

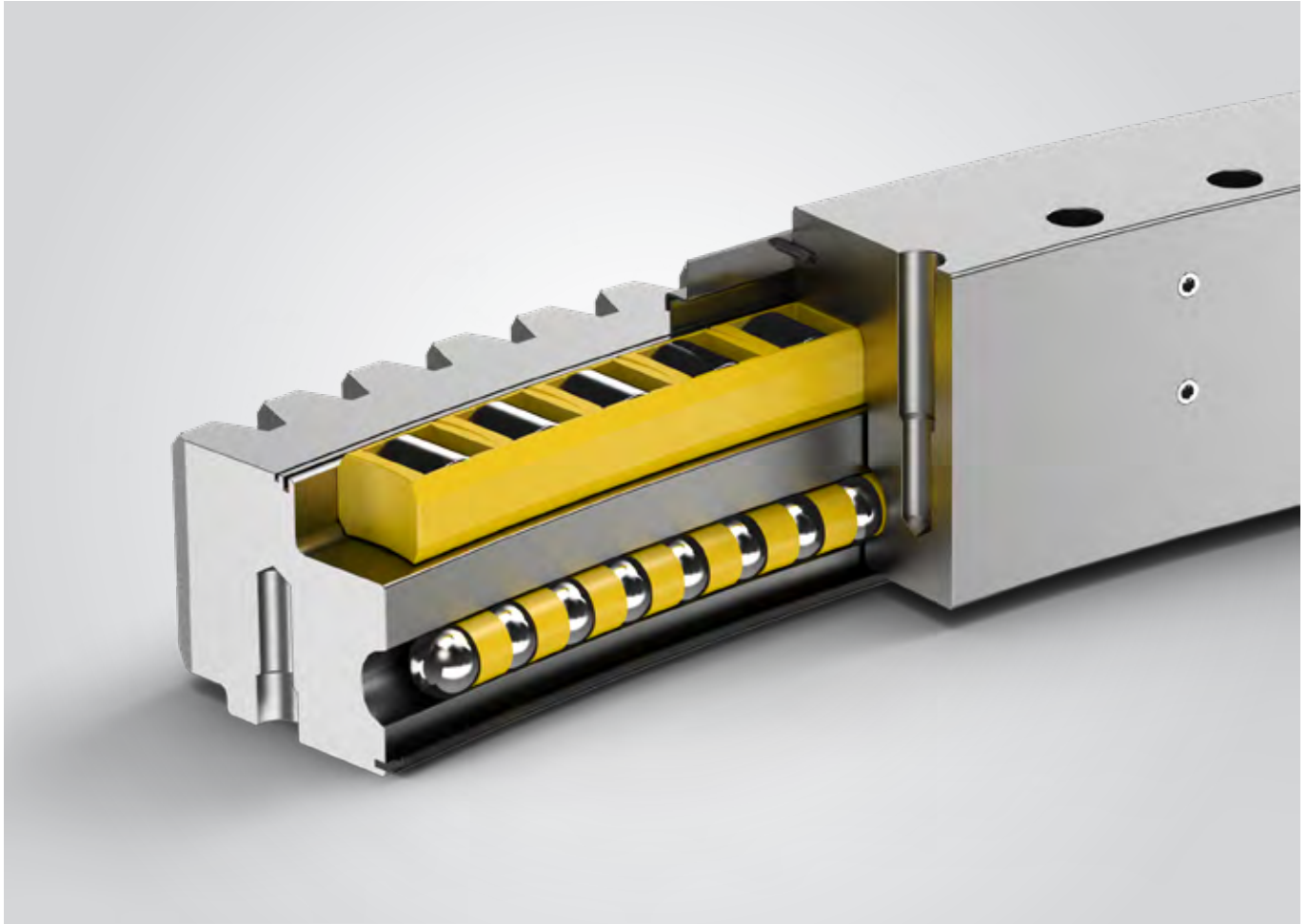

RKD\_ZA

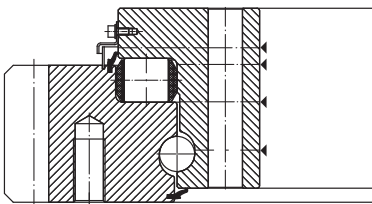

RKD\_ZJ

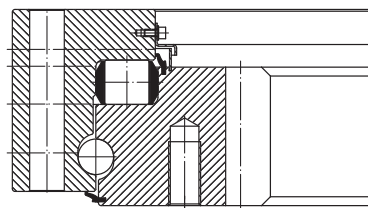

RKD\_ZO

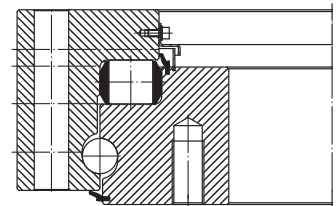
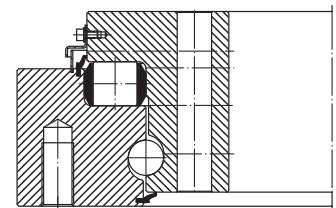

## External gear RKD\_32\_ZA

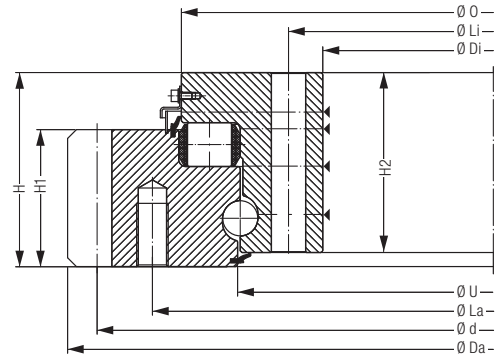
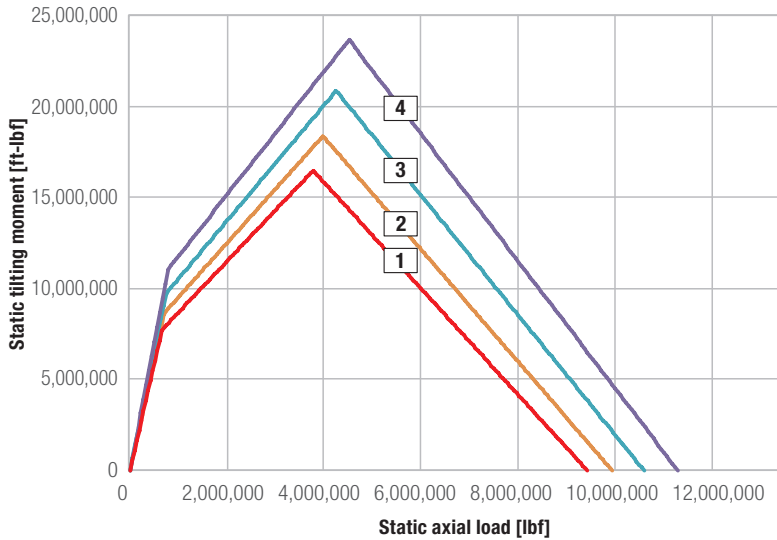

- 1 — RKD03550-032ZA15-900-000
- 2 — RKD03750-032ZA15-900-000
- 3 — RKD04000-032ZA15-900-000
- 4 — RKD04250-032ZA15-900-000

Bearing type	Bearing data								Bolt data						Gear data						Load rating		
	Weight	Outer diameter	Inner diameter	Total height	Outer diameter Inner ring	Inner diameter Outer ring	Height Outer ring	Height Inner ring	Pitch circle diameter Outer ring	Pitch circle diameter Inner ring	Number of bores per ring	Bolt diameter	Number of grease nipples per level	Pitch circle diameter	Module (metric)	Number of teeth	Profile shift	Tip reduction	Tooth width	Tooth forces (standard)	Tooth forces (maximum)	static	dynamic
	[lbs]	Da [inch]	Di [inch]	H [inch]	O [inch]	U [inch]	H1 [inch]	H2 [inch]	La [inch]	Li [inch]	n	M	n1	d [inch]	m [mm]	z	x*m [inch]	k*m [inch]	b [inch]	[lbf]	[lbf]	C <sub>stat</sub> [lbf]	C <sub>dyn</sub> [lbf]
1	4,461.6	148.54	132.20	6.26	141.61	138.15	4.29	5.63	143.23	134.57	76	27	10	146.14	16	232	0.630	-0.063	4.291	35,969	71,939	9,425,565	868,437
2	4,809.2	156.72	140.08	6.26	149.49	146.02	4.29	5.63	151.42	142.44	80	27	10	154.96	16	246	0.315	-0.063	4.291	35,969	71,939	9,937,005	892,492
3	5,011.6	166.17	149.92	6.26	159.33	155.87	4.29	5.63	160.87	152.28	84	27	12	164.41	16	261	0.315	-0.063	4.291	35,969	71,939	10,594,571	923,066
4	5,401.0	176.25	159.76	6.26	169.17	165.71	4.29	5.63	170.94	162.13	90	27	12	173.86	16	276	0.630	-0.063	4.291	35,969	71,939	11,288,781	955,213

## External gear RKD\_36\_ZA

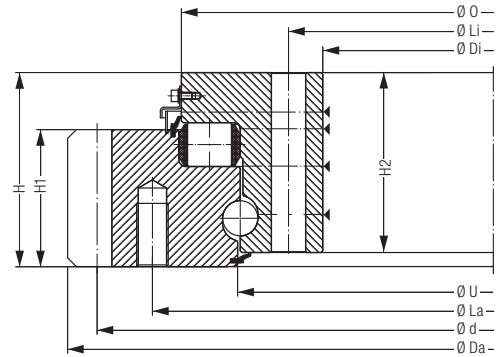
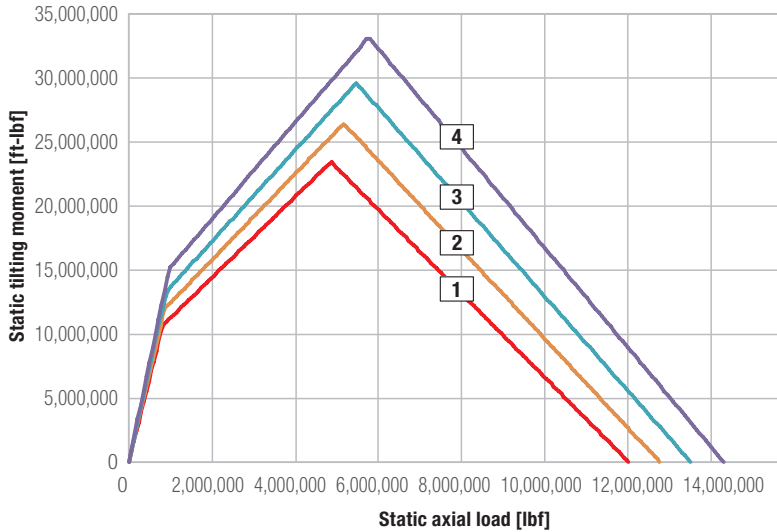

- 1 RKD04000-036ZA15-900-000
- 2 RKD04250-036ZA15-900-000
- 3 RKD04500-036ZA15-900-000
- 4 RKD04750-036ZA15-900-000

Bearing type	Bearing data								Bolt data						Gear data						Load rating		
	Weight	Outer diameter	Inner diameter	Total height	Outer diameter Inner ring	Inner diameter Outer ring	Height Outer ring	Height Inner ring	Pitch circle diameter Outer ring	Pitch circle diameter Inner ring	Number of bores per ring	Bolt diameter	Number of grease nipples per level	Pitch circle diameter	Module (metric)	Number of teeth	Profile shift	Tip reduction	Tooth width	Tooth forces (standard)	Tooth forces (maximum)	static	dynamic
	[lbs]	Da [inch]	Di [inch]	H [inch]	O [inch]	U [inch]	H1 [inch]	H2 [inch]	La [inch]	Li [inch]	n	M	n1	d [inch]	m [mm]	z	x*m [inch]	k*m [inch]	b [inch]			C <sub>stat</sub> [lbf]	C <sub>dyn</sub> [lbf]
1	6,142.4	167.10	149.29	6.89	159.49	155.71	4.92	6.26	161.22	151.89	76	30	12	164.41	18	232	0.709	-0.071	4.921	43,973	87,945	12,017,612	1,085,827
2	6,558.2	177.02	159.13	6.89	169.33	165.55	4.92	6.26	171.14	161.73	80	30	12	175.04	18	247	0.354	-0.071	4.921	43,973	87,945	12,762,853	1,120,673
3	6,980.6	186.94	168.98	6.89	179.17	175.39	4.92	6.26	181.06	171.57	84	30	14	184.96	18	261	0.354	-0.071	4.921	43,973	87,945	13,508,095	1,154,619
4	7,398.6	196.87	178.82	6.89	189.02	185.24	4.92	6.26	190.98	181.42	90	30	14	194.88	18	275	0.354	-0.071	4.921	43,973	87,945	14,300,097	1,190,813

## External gear RKD\_40\_ZA

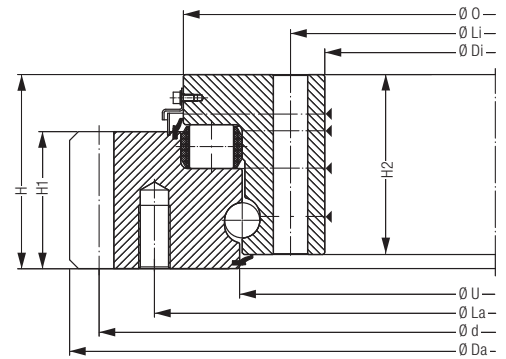
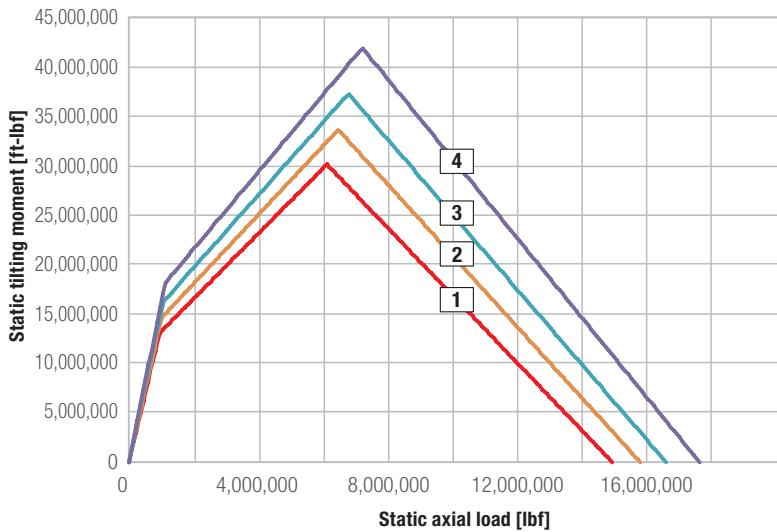

- 1 — RKD04500-040ZA15-900-000
- 2 — RKD04750-040ZA15-900-000
- 3 — RKD05000-040ZA15-900-000
- 4 — RKD05300-040ZA15-900-000

Bearing type	Bearing data								Bolt data						Gear data						Load rating		
	Weight	Outer diameter	Inner diameter	Total height	Outer diameter Inner ring	Inner diameter Outer ring	Height Outer ring	Height Inner ring	Pitch circle diameter Outer ring	Pitch circle diameter Inner ring	Number of bores per ring	Bolt diameter	Number of grease nipples per level	Pitch circle diameter	Module (metric)	Number of teeth	Profile shift	Tip reduction	Tooth width	Tooth forces (standard)	Tooth forces (maximum)	static	dynamic
	[lbs]	Da [inch]	Di [inch]	H [inch]	O [inch]	U [inch]	H1 [inch]	H2 [inch]	La [inch]	Li [inch]	n	M	n1	d [inch]	m [mm]	z	x*m [inch]	k*m [inch]	b [inch]	[lbf]	[lbf]	C <sub>stat</sub> [lbf]	C <sub>dyn</sub> [lbf]
1	8,080.6	188.03	168.35	7.20	179.37	175.20	5.24	6.57	181.57	171.18	72	33	14	185.83	20	236	0.394	-0.079	5.236	51,998	103,997	14,938,554	1,322,776
2	8,351.2	197.48	178.19	7.20	189.21	185.04	5.24	6.57	191.02	181.02	76	33	14	195.28	20	248	0.394	-0.079	5.236	51,998	103,997	15,797,100	1,362,792
3	8,980.4	207.72	188.03	7.20	199.06	194.88	5.24	6.57	201.26	190.87	80	33	16	205.51	20	261	0.394	-0.079	5.236	51,998	103,997	16,598,319	1,398,312
4	9,523.8	219.53	199.84	7.20	171.50	206.69	5.24	6.57	213.07	202.68	84	33	16	217.32	20	276	0.394	-0.079	5.236	51,998	103,997	17,628,618	1,444,173

## External gear RKD\_45\_ZA

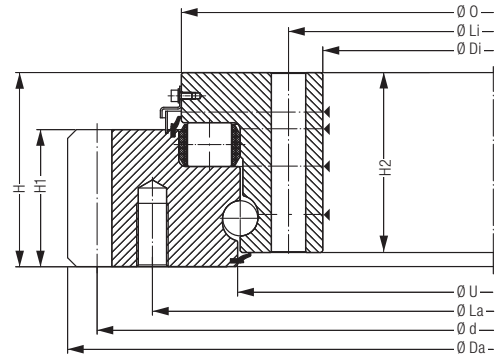
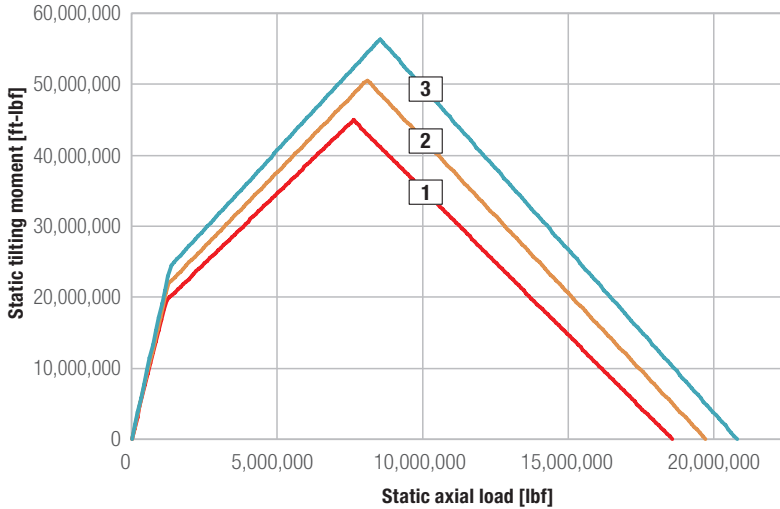

- 1 RKD05000-045ZA15-900-000
- 2 RKD05300-045ZA15-900-000
- 3 RKD05600-045ZA15-900-000

Bearing type	Bearing data								Bolt data					Gear data							Load rating		
	Weight	Outer diameter	Inner diameter	Total height	Outer diameter Inner ring	Inner diameter Outer ring	Height Outer ring	Height Inner ring	Pitch circle diameter Outer ring	Pitch circle diameter Inner ring	Number of bores per ring	Bolt diameter	Number of grease nipples per level	Pitch circle diameter	Module (metric)	Number of teeth	Profile shift	Tip reduction	Tooth width	Tooth forces (standard)	Tooth forces (maximum)	static	dynamic
	[lbs]	Da [inch]	Di [inch]	H [inch]	O [inch]	U [inch]	H1 [inch]	H2 [inch]	La [inch]	Li [inch]	n	M [mm]	n1	d [inch]	m [mm]	z	x*m [inch]	k*m [inch]	b [inch]	[lbf]	[lbf]	C <sub>stat</sub> [lbf]	C <sub>dyn</sub> [lbf]
1	11,442.2	208.57	186.89	7.99	199.33	194.69	6.02	7.36	201.46	189.96	76	36	16	206.14	22	238	0.433	-0.087	6.024	65,779	131,558	18,556,629	1,649,873
2	12,324.4	220.69	198.70	7.99	211.14	206.50	6.02	7.36	213.58	201.77	80	36	16	218.27	22	252	0.433	-0.087	6.024	65,779	131,558	19,707,426	1,700,230
3	12,680.8	231.95	210.51	7.99	222.95	218.31	6.02	7.36	224.84	213.58	84	36	18	229.53	22	265	0.433	-0.087	6.024	65,779	131,558	20,786,284	1,749,238

## External gear RKD\_50\_ZA

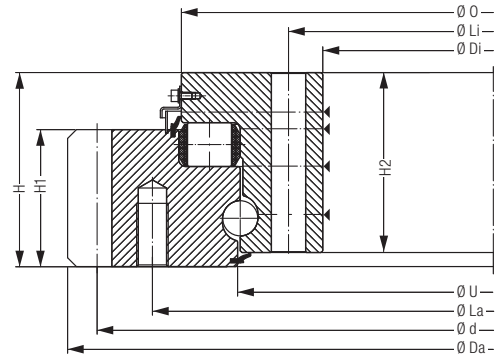
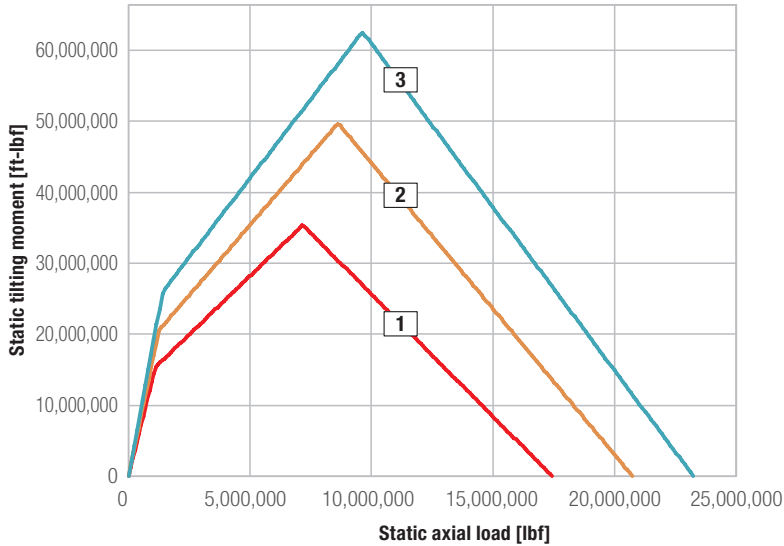

- 1 — RKD04200-050ZA15-900-000
- 2 — RKD05000-050ZA15-900-000
- 3 — RKD05600-050ZA15-900-000

Bearing type	Bearing data								Bolt data					Gear data						Load rating			
	Weight	Outer diameter	Inner diameter	Total height	Outer diameter Inner ring	Inner diameter Outer ring	Height Outer ring	Height Inner ring	Pitch circle diameter Outer ring	Pitch circle diameter Inner ring	Number of bores per ring	Bolt diameter	Number of grease nipples per level	Pitch circle diameter	Module (metric)	Number of teeth	Profile shift	Tip reduction	Tooth width	Tooth forces (standard)	Tooth forces (maximum)	static	dynamic
	[lbs]	Da [inch]	Di [inch]	H [inch]	O [inch]	U [inch]	H1 [inch]	H2 [inch]	La [inch]	Li [inch]	n	M [mm]	n1	d [inch]	m [mm]	z	x*m [inch]	k*m [inch]	b [inch]	[lbf]	[lbf]	C <sub>stat</sub> [lbf]	C <sub>dyn</sub> [lbf]
1	10,555.6	178.39	155.20	8.70	168.03	162.99	6.14	8.07	170.47	158.27	72	36	12	175.75	24	186	0.472	-0.094	6.142	73175	146,351	17,438,879	1,714,618
2	12,564.2	209.57	186.69	8.70	199.53	194.49	6.14	8.07	201.97	189.76	80	36	16	206.93	24	219	0.472	-0.094	6.142	73175	146,351	20,747,842	1,878,953
3	14,073.4	233.20	210.31	8.70	223.15	218.11	6.14	8.07	225.59	213.39	90	36	18	230.55	24	244	0.472	-0.094	6.142	73175	146,351	23,251,989	1,995,629





# Further information

On our homepage at [bearings.liebherr.com](http://bearings.liebherr.com) you can find more information on slewing bearings, as well as our request datasheet.

## Request Data

### Slewing Bearings

#### General Information

Request Date:	Telephone:
Company:	E-Mail:
Contact Person:	Application:
Road:	Machine / Type:
Postcode:	Location:
Country:	Required quantity:
	Requested delivery date:

#### Application

Application (please describe briefly and include a sketch):

Project name:

Exchangeable with existing solution:  yes (please include drawing)  no

#### Operating conditions and loads

**Position of rotary axis**

vertical  horizontal  alternating (please call to discuss!)

exerted load

suspended load

**Type of movement**

Pivotal movement  Continual rotational movement

**Bearing load**

Tilting moment [kNm]	Axial load [kN]	Radial load [kN]	Total bearing rotations or Adjusting speed [U/s] or [°/s] and time unit [h] or Swing angle [°] and number of swing cycles [1]

Additional design features	Operation	Stationary
Temperature range [°C]:	min:      max:	min:      max:
Sealing system:	<input type="checkbox"/> Sealed on both sides <input type="checkbox"/> Dust seal	<input type="checkbox"/> Special seal against:
Corrosion protection (ISO 12944 part 5):	<input type="checkbox"/> Untreated, preserved <input type="checkbox"/> C3 <input type="checkbox"/> C4 <input type="checkbox"/> C5	
Standards, approval conditions (EN10204):	<input type="checkbox"/> 3.1 <input type="checkbox"/> 3.2 if yes, approval company:	<input type="checkbox"/> BV <input type="checkbox"/> Others:
	<input type="checkbox"/> DNV/GL <input type="checkbox"/> ABS <input type="checkbox"/> LRS <input type="checkbox"/> CSR	





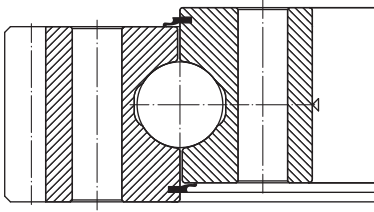

KUD\_V

Ball bearings; four-point contact

---

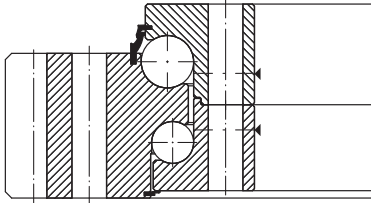

KUD\_Z

Double-row ball bearings

---

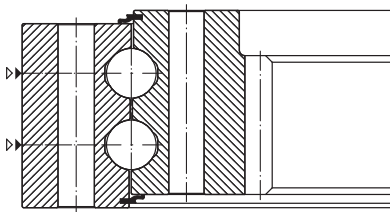

KUD\_W

Double-row ball bearings;  
four-point contact

---

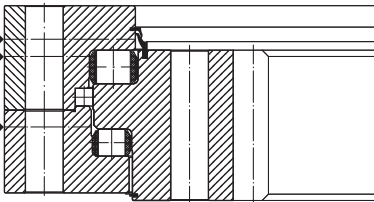

ROD\_D

Triple-row roller bearings\*

---

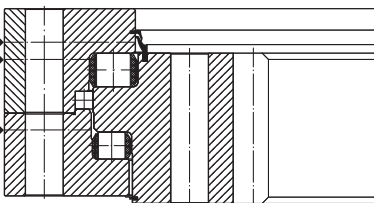

ROD\_D

Triple-row roller bearings

---

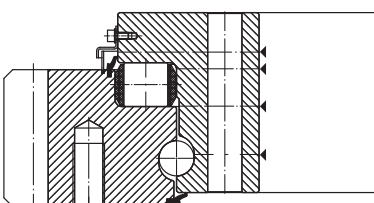

RKD

Combined roller  
and ball bearings

---

- Klapper-  
Verkürzte Seite

# Liebherr Components

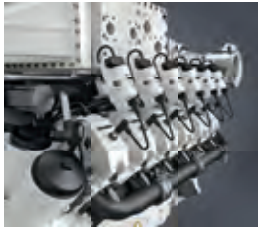

Gas engines



Diesel engines



Fuel injection systems



Axial piston hydraulics



Hydraulic cylinders



Slewing bearings



Gearboxes and winches

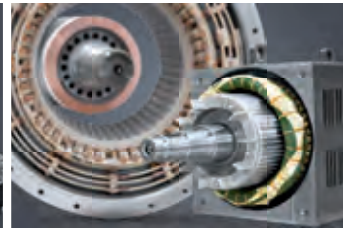

Electric machines

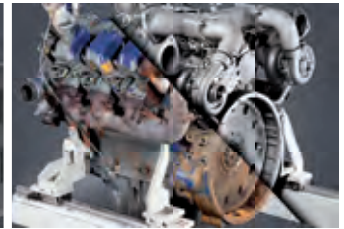

Remanufacturing



Human-machine interfaces and gateways



Control electronics and sensor technology



Power electronics

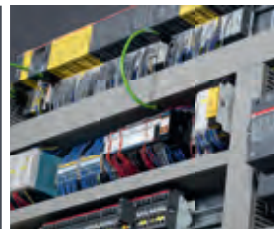

Control cabinets



Software

From A to Z – the components division of the Liebherr Group offers a broad range of solutions in the area of mechanical, hydraulic, electric and electronic drive system and control technology. The efficient components and systems are produced at a total of ten production sites around the world to the highest standards of quality. Central contact persons for all product lines are available to our customers at Liebherr-

Components AG and the regional sales and distribution branches.

Liebherr is your partner for joint success: from the product idea to development, manufacture and commissioning right through to customer service solutions like remanufacturing.

[components.liebherr.com](http://components.liebherr.com)