

Rugged, Durable and Customised

Hydraulic Cylinders by Liebherr

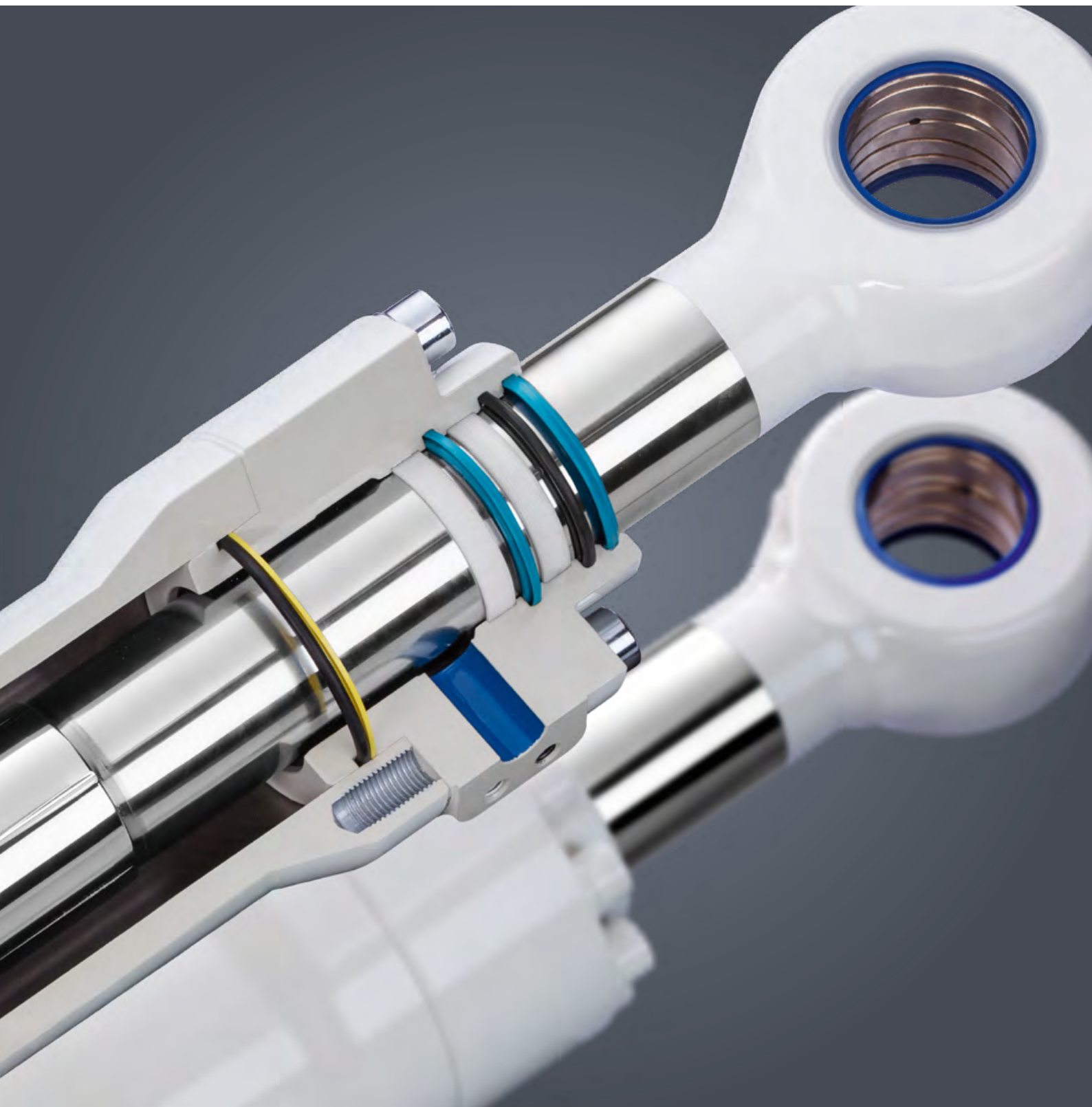

LIEBHERR

Hydraulic cylinders by Liebherr





Since 1958 the Liebherr Group is developing and producing hydraulic cylinders at the main site in Kirchdorf an der Iller. Since 2018, there is another production facility especially for the assembly, testing and painting of the components in the Oberopfingen suburb of Kirchdorf. The product portfolio reaches from standard cylinders for high dynamic requirements to large heavy duty cylinders and suspensions through to high-stress lightweight and special cylinders. In addition, hydraulic power units round off the portfolio.

Advantages

The customers of Liebherr benefit from the decades of experience and constantly expanding product portfolio. High quality, customer satisfaction, as

well as environmentally-friendly products and manufacturing processes, are top priority.

Flexibility

Customised products thanks to state-of-the-art technologies

Engineering know-how

Decades of experience for tailormade solutions

Quality

Quality awareness for highest standards

Hydraulic cylinder series-production ranges

Flexible configuration for all applications

Broad range of services

Expertise in hydraulic systems

Flexibility

State-of-the-art technologies enable individual customer requirements to be implemented in customised products. A diversified and flexible machine fleet forms the basis for this. The ultimate goal is to guarantee efficient and flexible production with short lead times.



Customised products thanks to state-of-the-art technologies

Wide production range

Liebherr is able to manufacture hydraulic cylinders with a stroke length up to 8,000 mm. The production is distinguished by a vertical range of manufacture. All production takes place in-house, from the complete machining of piston rods on special machining centres, to very efficient deep-hole drills and precise honing of the tubes through to the cylinder installation, inspection and robot-supported painting.

Modern welding technologies

Robotic welding systems with automatic clamping, centring and joining of the components guarantee consistently high quality with the most efficient working method. The diverse materials are welded together without additives into a high-strength structure by means of friction welding.

High innovative strength

At Liebherr innovations and creative ideas can not only be found in the products, but also in the continuously developed processes. The focus is on reproducible and stable processes in order to meet the highest quality requirements.

Complete machining

Piston rods and cylinder tubes are machined in ultramodern lathe/milling machines. Several manufacturing steps are completed at the same time in one process. An automatic tool change during machining ensures short lead times.

Friction welding

During friction welding piston rods and rod heads are fused at an upset force of up to 300 tonnes into a homogeneous structure. The result is a quality comparable to a forged part. This particularly efficient process is used for diameters up to 130 mm and lengths up to 3,000 mm.

Honing, peeling and roller-burnishing

Liebherr performs the finishing of the cylinder running surfaces in relation to size, shape and surface. Depending on the product, this is carried out by means of peeling and roller-burnishing or honing to an internal diameter of 600 mm.

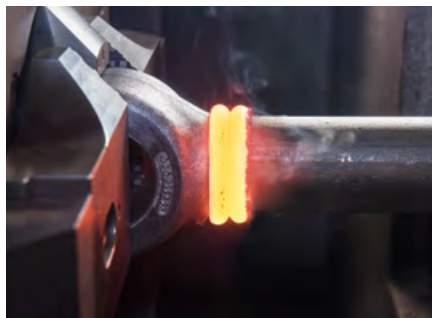

Engineering know-how

In close cooperation with our customers, hydraulic specialists show an interest in customer requirements in an open-minded way and find individual solutions which meet the respective requirements. Supported by modern CAD systems and simulation processes, the result is high-quality and reliable products in every detail.

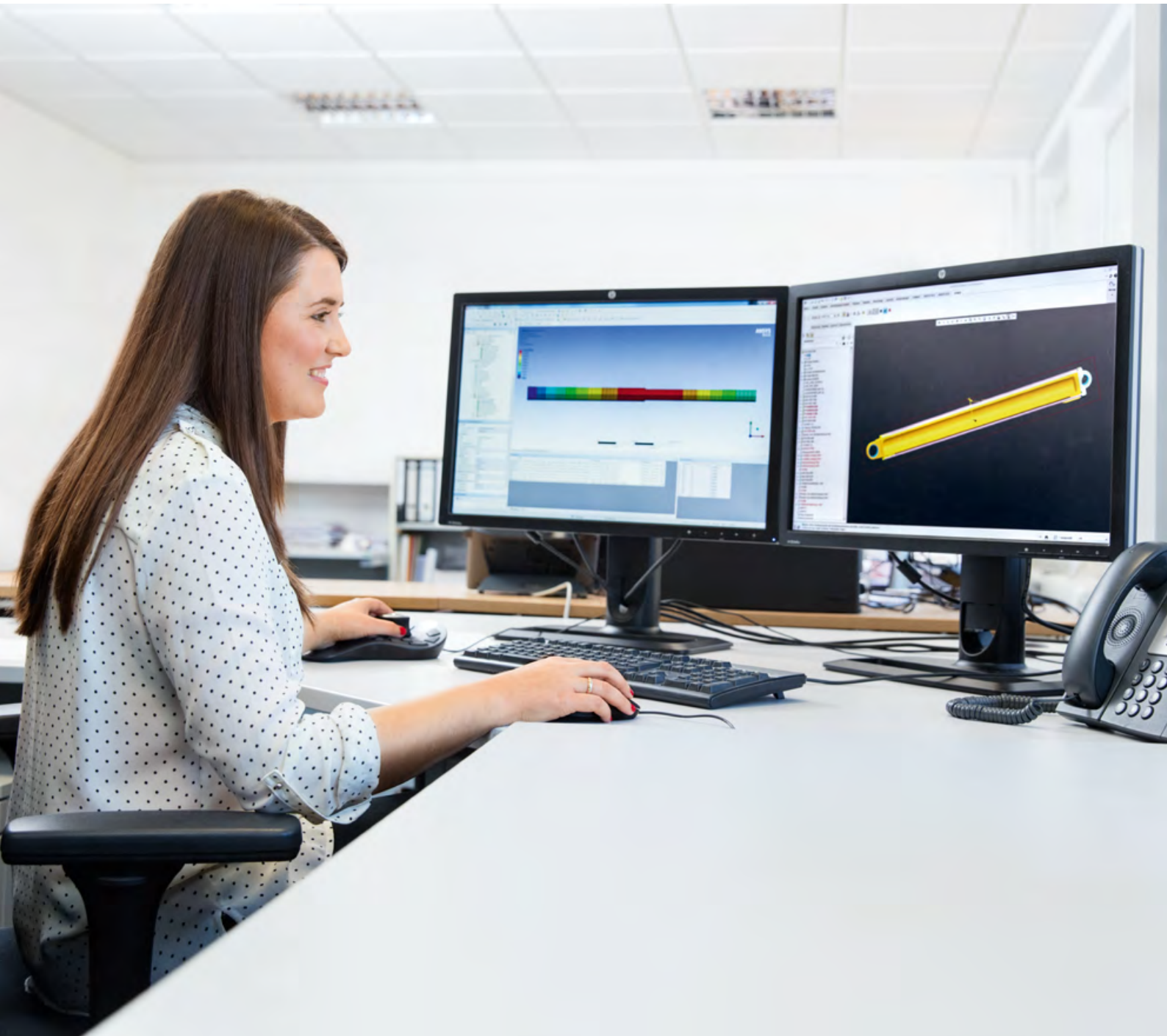

Decades of experience for tailor-made solutions

Sealing systems and coatings

Sealing and guiding elements are carefully matched to the respective application. In addition to the surface quality, the high manufacturing accuracy of the components is also decisive for the proper and lasting function of the hydraulic cylinders. The resulting optimal pairing guarantees high availability and a long service life of the products. An optimal coating of the piston rods provides protection against corrosion and wear. Liebherr offers common chrome and nickel-chrome coatings, as well as a variety of customised special solutions. Liebherr accurately matches the selected coating and sealing system.

High-performance software

During the design stage the development engineers are supported by modern 3D CAD systems and diverse calculation methods. The increasing requirements of the end products require detailed know-how about components and materials. This is why state-of-the-art simulation processes are already used for the product development. In addition, the simulation results are compared with reality within the framework of intensive testing such as pulse testing or endurance tests. Accurate solutions corresponding to customer requirements are created in this way.

Design using finite element method (FEM)

Liebherr designs hydraulic cylinders and their individual parts using the finite element method. By calculating the ideal force and stress curve, components can be designed to minimise weight and high safety factors can be observed.

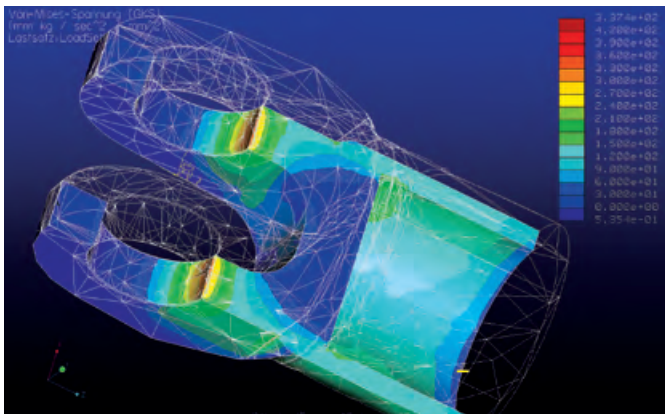

Lightweight design

Special requirements in relation to weight and capacity of the hydraulic cylinders are realised for example through thin-walled cylinder tubes and hollowed piston rods. Stability and function are guaranteed with the use of high-strength materials.

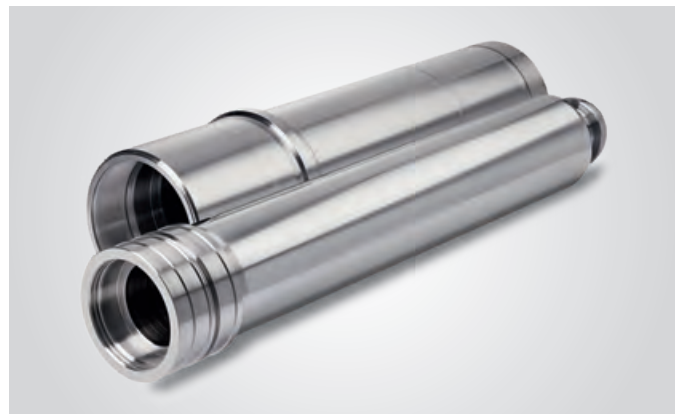

Quality

The name Liebherr is synonymous with quality. Each step of the value-added process is aligned accordingly. The foundation for a high-quality product is already laid in the development. Other elements of the comprehensive quality management system include the intensive supplier support, the permanently operational quality assurance, as well as the continuous improvement of all business processes.



Quality awareness for highest standards

Supplier management

Extensive meetings with suppliers and quality audits form the basis for the high quality of Liebherr hydraulic cylinders. The expected quality and short delivery times are ensured from the beginning through controlled processes with the suppliers. Requirements extending beyond the current industry standards apply here.

Central quality and process management

All operational processes are subject to constant inspections and improvement. Employees in the individual areas work hand-in-hand so that processes run smoothly and are integrated seamlessly. Before the products are released for delivery, they are subject to a comprehensive check.

Operational quality assurance

The consistently high component quality is guaranteed by comprehensive and intensive initial sample and random sample checks in addition to the inspection in the process. State-of-the-art testing methods, such as computer-aided 3D measurement methods, are used here. Batches are tracked consistently for safety-relevant hydraulic cylinders.

Certified company

DIN EN ISO 9001:2015:

Guarantees a functioning quality management system and the continuous improvement process in the company.

EN 1090-1:2009+A1:2011,EXC4 i.a.w. EN 10190-2:

Qualified to manufacture hydraulic components with the highest requirements, for example components, which are used for earthquake protection of nuclear power plants.

DGRL 97/23/EG-AD 2000:

Permits the manufacture of pressure equipment, such as hydraulic accumulators.

DIN EN ISO 3834-2:2006:

Certifies the compliance of comprehensive quality requirements for fusion welding of metallic materials.

American Society of Mechanical Engineers (ASME)

This set of rules relates to the production of pressure equipment for the worldwide market according to ASME guidelines.

Weld inspection

Welds are inspected by ultrasonic inspections or penetrant testing in order to guarantee the highest quality.

Test benches

The reliability of the hydraulic cylinders is ensured through a complete functional and leak test. The test results are recorded automatically. This ensures complete documentation.

Certificates

The certification is effected in conjunction with recognised and well-known testing, certifying and classification bodies.



Hydraulic Cylinder Series-Production Ranges

The hydraulic cylinder portfolio of Liebherr contains of three standard series-production ranges in total. These series-production ranges offer a product for the customers that is optimized for the specific requirements in each application. Thus, the customers benefit from economic and individual configurable solutions with short delivery times.

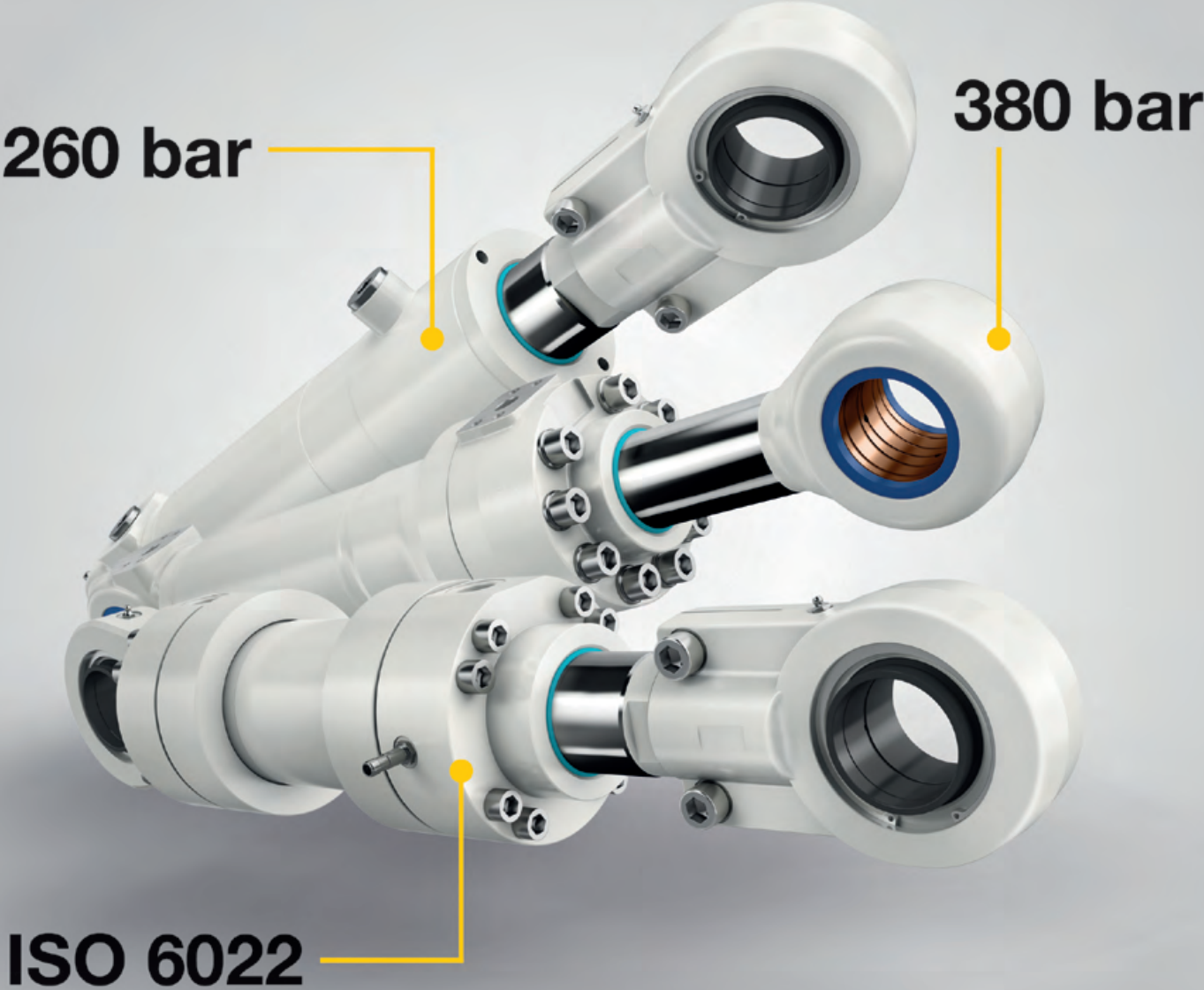

For all applications

380 bar series-production range

The hydraulic cylinders in the 380 bar series are mainly used in mobile applications. They are used wherever durable and robust products are required in highly dynamic applications. The “eye-eye mounting” designed specially for connection in construction machines guarantees optimal operation.

A highlight is the optional equipment with Liebherr's own position transducer LiView®, which reliably records the linear movement during work.

Series-production range according to ISO 6022

The series designed specially for industry applications is designed and manufactured according to the applicable standards of ISO 6022. The products are used in various stationary applications such as steelworks, for example. There is a wide selection of mounting types available. Furthermore, the hydraulic cylinders can be equipped with a large portfolio of configurable additional optional equipment (e.g. position transducer, end of stroke cushioning, proximity switch or pressure sensor) as required.

260 bar series-production range

With the 260 bar series Liebherr offers its customers a range of hydraulic cylinders optimised to what is essential, which can still also be used in demanding conditions – both in the mobile and stationary area. There is a broad range of mounting types as well as two alternative oil connections and piston rod coatings available. In order to be able to realise the most economical solution for the respective target application, no extended functions such as sensor technology or cushioning options are intended for this series.

Highly dynamic

As hoist, stick or bucket cylinder, the products of the 380 bar series-production range move reliable mobile machines.



Compact

Hydraulic cylinders of the 260 bar series-production ranges convince with a compact design in mobile and stationary applications.



For the rough use

The solutions of the series-production range according to ISO 6022 meet the environmental conditions such as prevailed in steel plants without any problems.

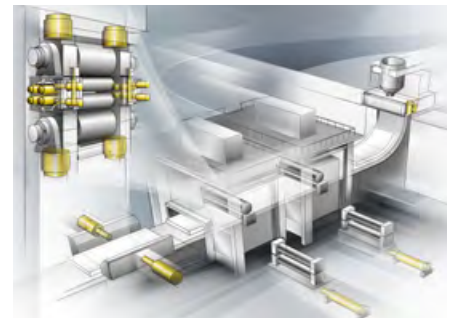

Flexible Configuration



The series-production ranges at a glance

	380 bar series-production range	260 bar series-production range	Series-production range acc. to ISO 6022
Type	Differential cylinder	Differential cylinder	Differential cylinder
Operating pressure	Max. 380 bar	Max. 260 bar	Max. 250 bar
Stroke lengths	Up to 2,300 mm*	Up to 3,100 mm (depending on application)	Up to 2,700 mm (depending on application)*
Piston diameter	100 – 220 mm	90-230 mm	63 – 320 mm
Piston rod diameter	65 – 150 mm	50-150 mm	40 – 220 mm
Mounting types	Pin diameter 70 – 130 mm	Round flange at head, spherical bearing eye or bushing at base, trunnion mounting	Round flange at head/base, spherical bearing/bushing at base, trunnion or foot mounting
Piston rod connection	piston head width 90 – 150 mm	Rod thread; available with appropriate swivel head as option	Rod thread; available with appropriate swivel head as option
Media connection	SAE 3/4" – 1 1/2"	Threaded connection in inches; metric threaded connection	Threaded connection in inches; metric/american UNF threaded connection or SAE connection
Hydraulic fluids	Hydraulic oils acc. to ISO 4406: 20/18 /15	Hydraulic oils acc. to ISO 4406: 20/18/15	Hydraulic oils acc. to ISO 4406: 20/18/15
Coating	Chrome, nickel-chrome*	Chrome coating with 25 µm (±5 µm); double chrome coating AASS with 96 h Rating 10	Chrome coating with 25 µm (±5 µm); double chrome coating AASS with 96 h Rating 10
Corrosion protection	Standard painting, maritime painting	Primed; painted at the customer's request	Primed; painted at the customer's request
Operating temperature	-30 °C to +95 °C	-20 °C to +80 °C	-20 °C bis +80 °C
Piston speed	bis 1 m/s	Up to 1 m/s	Up to 1 m/s
Type of use	Dynamic, static	Dynamic, static	Dynamic, static
Options	end of stroke cushioning (piston and / or rod side), position transducer		position transducer, proximity switch, measuring coupling, pressure sensor, adjustable end of stroke cushioning

*Further variations on request

380 bar series-production range

The production-range offers 40 basic variants and several additional options, selected for the highly dynamic and demanding use.



260 bar series-production range

The 28 variants of the 260 bar series-production range offers the optimal solution for applications without high additional requirements.



Series-production range according to ISO 6022

The series-production range expand the dimensions of the ISO standard with its 24 basic variants.



Broad range of services

The entire range of services from Liebherr in the area of hydraulics, from the individual component to the system solution, offers great flexibility. Customers can also choose from a comprehensive range of services. From advice on customised development to services such as commissioning and maintenance, customers benefit from the high application expertise of Liebherr.

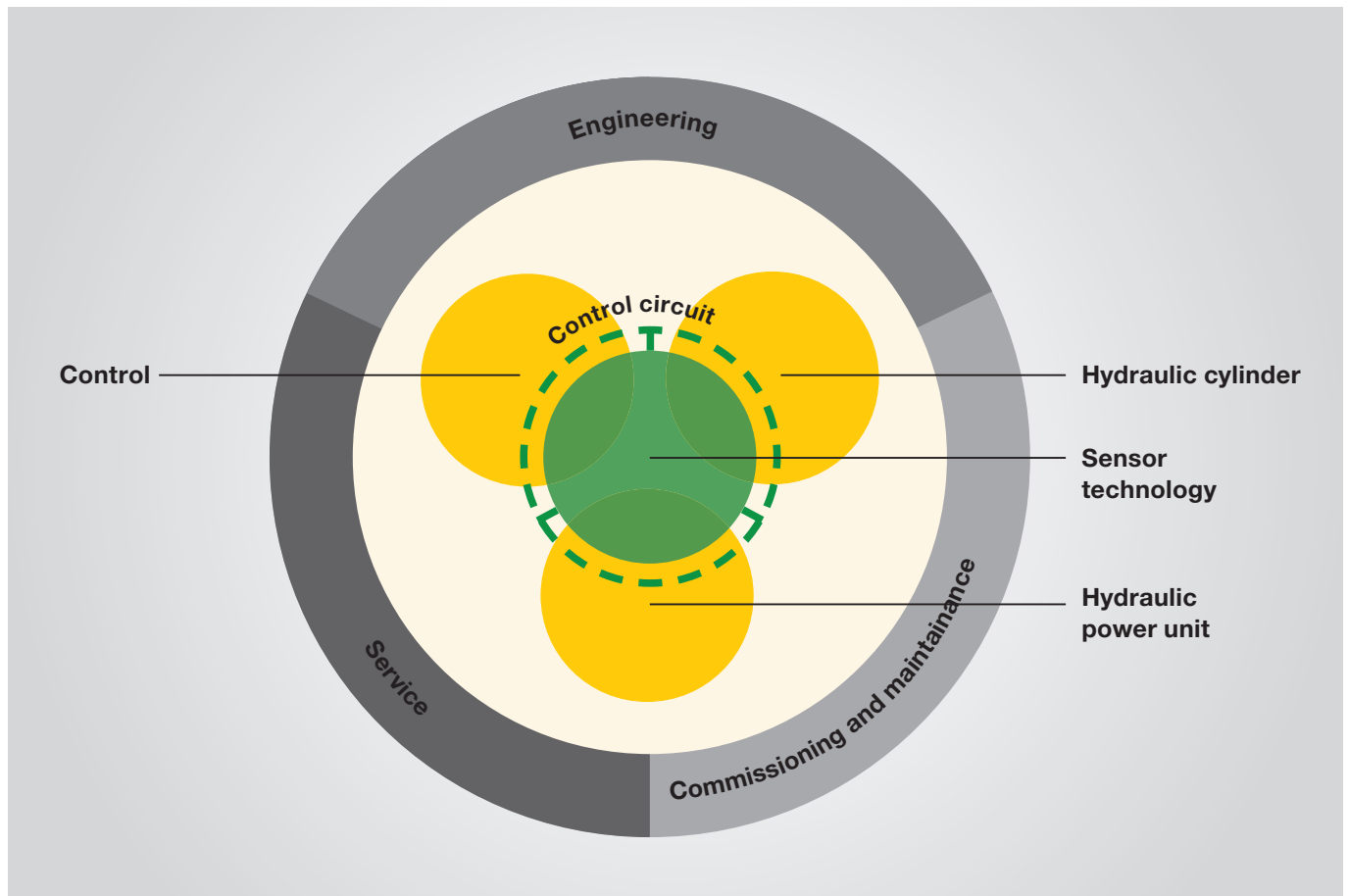

Hydraulic cylinders for mobile and stationary applications



Control and sensor technology



Hydraulic power units

Expertise in hydraulic systems

In addition to hydraulic cylinders for mobile and stationary applications, as well as suspensions, Liebherr also offers tailor-made hydraulic power units and other components for hydraulic system solutions. For each task the optimal sensor technology solution is also developed. Here Liebherr uses tried and tested sensor technology components from well-known manufacturers and complements these with innovative in-house developments if needed.

Hydraulic cylinders for mobile and stationary applications

- Stroke lengths up to 8,000 millimetres
- Nominal diameters up to 500 millimetres
- Operating pressures up to 630 bar
- Lifting speeds up to 1 m/s
- Operating temperatures from -40°C to +80°C
- Chrome coatings, nickel-chrome, HVOF and many others
- Corrosion protection for continental and maritime environments
- End of stroke cushioning (the piston side and/or the rod side)

Control and sensor technology

- Controls from the Liebherr Group
- Limit and proximity switches, as well as position transducers
- Depending on the application: Use of innovative in-house developments

Hydraulic power units

- Drive power up to 75 kW
- Capacity up to 2,000 l
- Operating pressure up to 600 bar, also higher upon customer request
- Flow volume upon request
- Main components from Liebherr or according to customer specifications
- Customised development and assembly
- Different pump types available
- Equipment with monitoring elements and accessories such as control and accumulators possible

Engineering

Liebherr offers comprehensive engineering services for the development of application-specific solutions and is available to its customers as a competent partner.



Service

The global service network of Liebherr ensures proximity to customers at all times. The high availability of original spare parts and the Liebherr Reman programme ensure very long product life cycles.



Commissioning and maintenance

Professional employees in customer services provide competent advice and develop the best solution for each customer. Experienced technicians provide support during commissioning and maintenance.



Examples of use

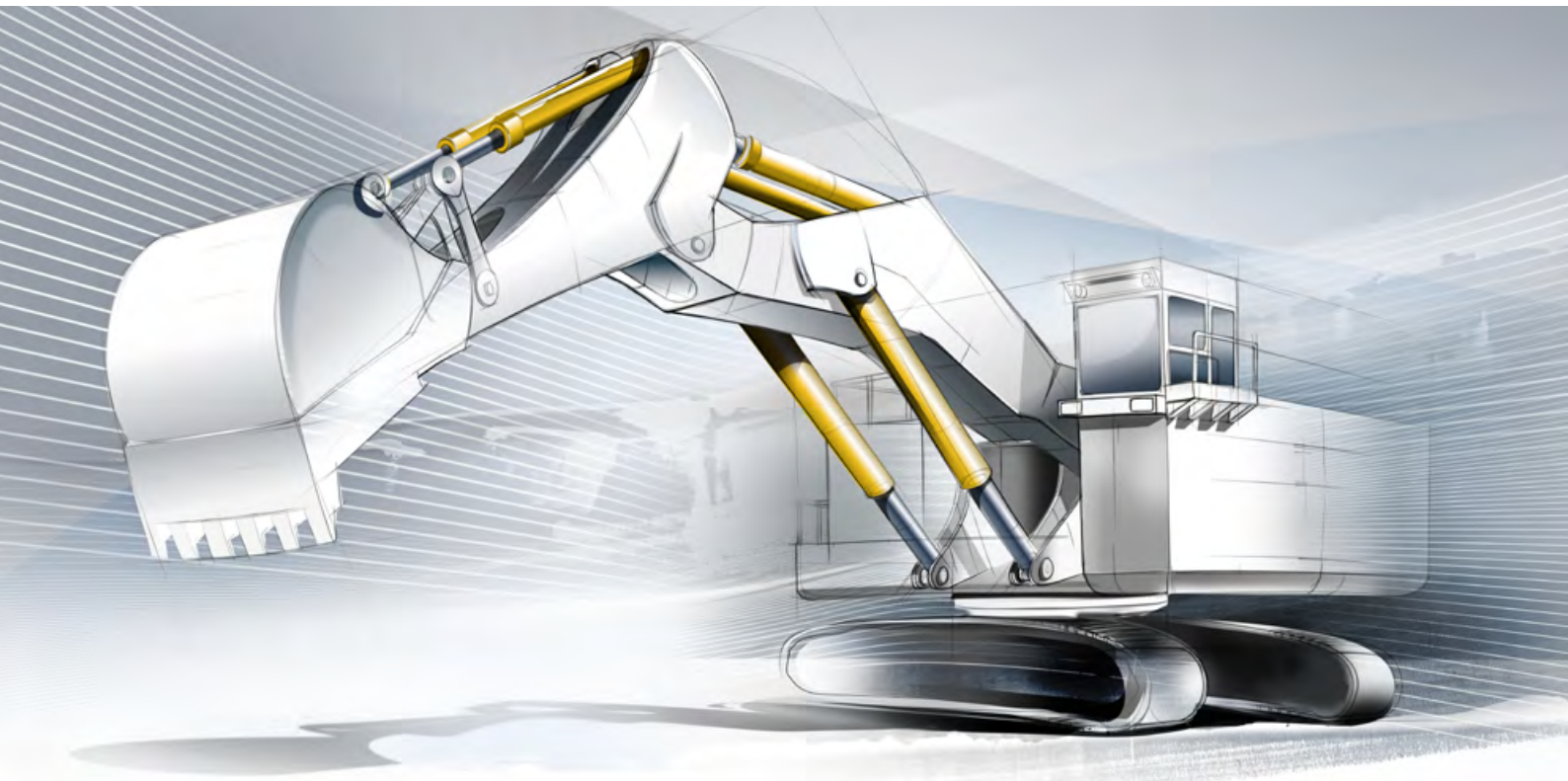

Mining

For heavy duty use

For mining applications, hydraulic cylinders have to cope with high static and dynamic forces. These requirements are taken into account by a robust design optimised for durability and with the special selection of materials, which are based on decades of experience. Liebherr manufactures the piston rods, for example, from high-strength forged parts.

Life cycle management

Both the hydraulic cylinders and the suspensions for mining applications are designed so that they can be processed up to three times within the framework of life cycle management. A service life of up to 80,000 operating hours is thus achieved.

Reduced weight for high productivity

Through weight reduction, particularly for bucket cylinders and stick cylinders of a mining excavator, its productivity can be increased significantly. This is why Liebherr offers diverse concepts for weight reduction depending on customer requirements, also for highly dynamic applications.

Suspensions in a mining truck

An additional use of a piston accumulator is not required with the compact design and the use of an oil-gas mixture.



Attachment cylinders

The large cylinders designed for high dynamic and static loads are used for example as lifting or stick cylinders or bucket rams.



Steering cylinders

Thanks to the absolute reliability and durability, Liebherr cylinders are ideal for safety-critical use as steering cylinders.



Examples of use

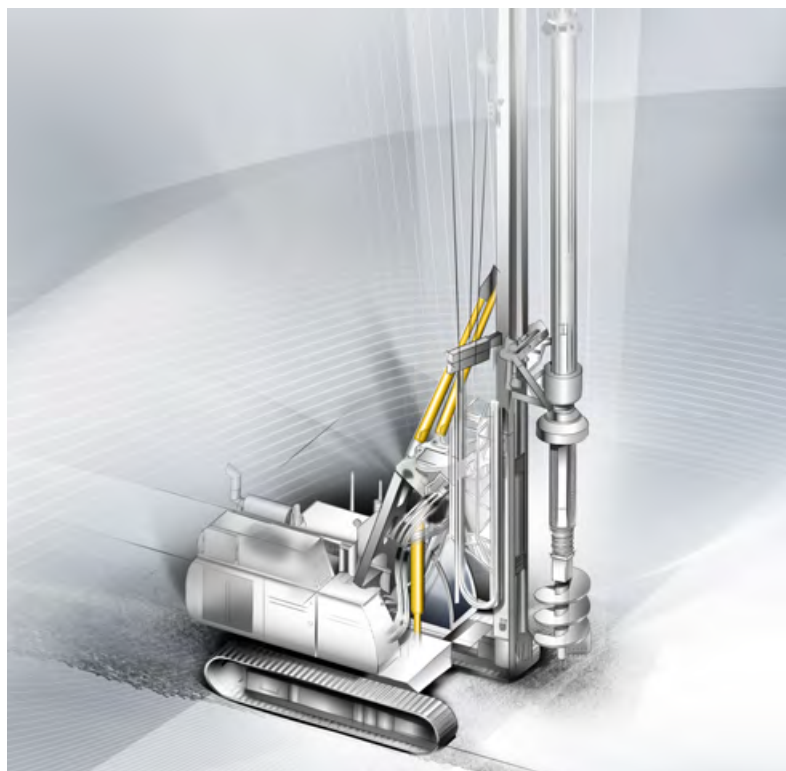
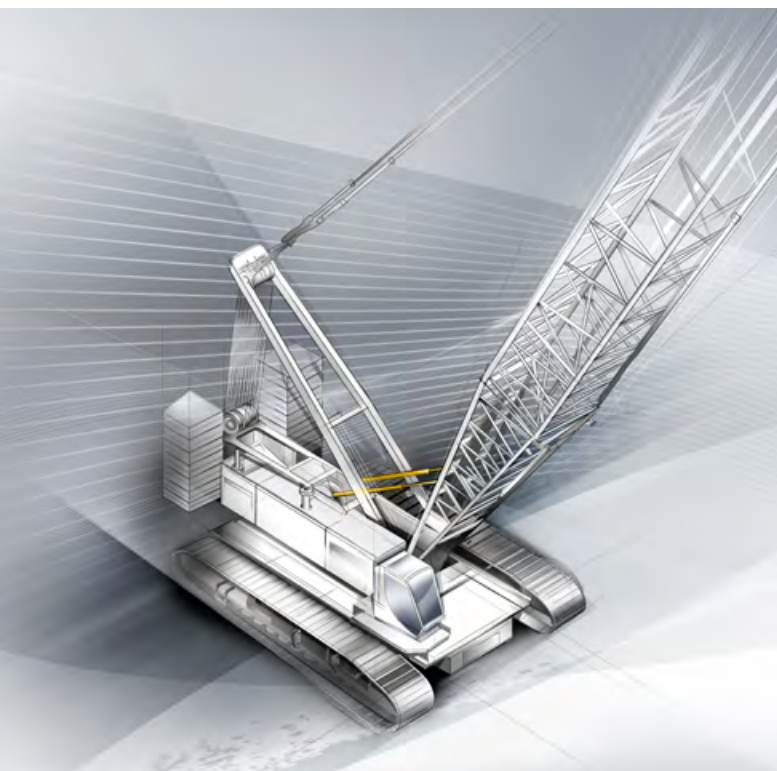

Building construction and civil engineering

Durable and reliable

Since the market launch of mobile cranes and excavators in the 1950s, hydraulic cylinders have been proving their performance in these machines. They are now used in a variety of different cranes, civil engineering machines and construction machines and fulfil diverse functions in these fields. The comprehensive know-how of Liebherr guarantees durability and reliability. Therefore, the customer can choose between two standard product series for the pressure range up to 260 bar or rather up to 380 bar besides individual developments.

Intelligent additional options

For additional precision and safety, Liebherr hydraulic cylinders are equipped with end position cushioning, position transducers, limit and proximity switches, as well as other sensor technology, according to customer needs.

Stability

The highest requirements are also satisfied in lightweight hydraulic cylinders from Liebherr, e.g. for cranes and other equipment with road approval. High-strength materials in thin-walled cylinder tubes or hollowed piston rods provide stability and safety.

Sealing systems

At Liebherr the sealing systems are optimally coordinated to the respective application and selected so that they are maintenance-free and leakage-free. So-called tandem sealing systems, consisting of primary and secondary sealing, ensure maximum durability.

Pull cylinders

Pull cylinders are used for example for tensioning mobile crane ropes.



Ballast cylinders

Ballast cylinders carry ballast weights in mobile cranes and thus fulfil a relevant safety function.



Support cylinders

These cylinders are used in numerous mobile construction machines for reliable support.



Examples of use

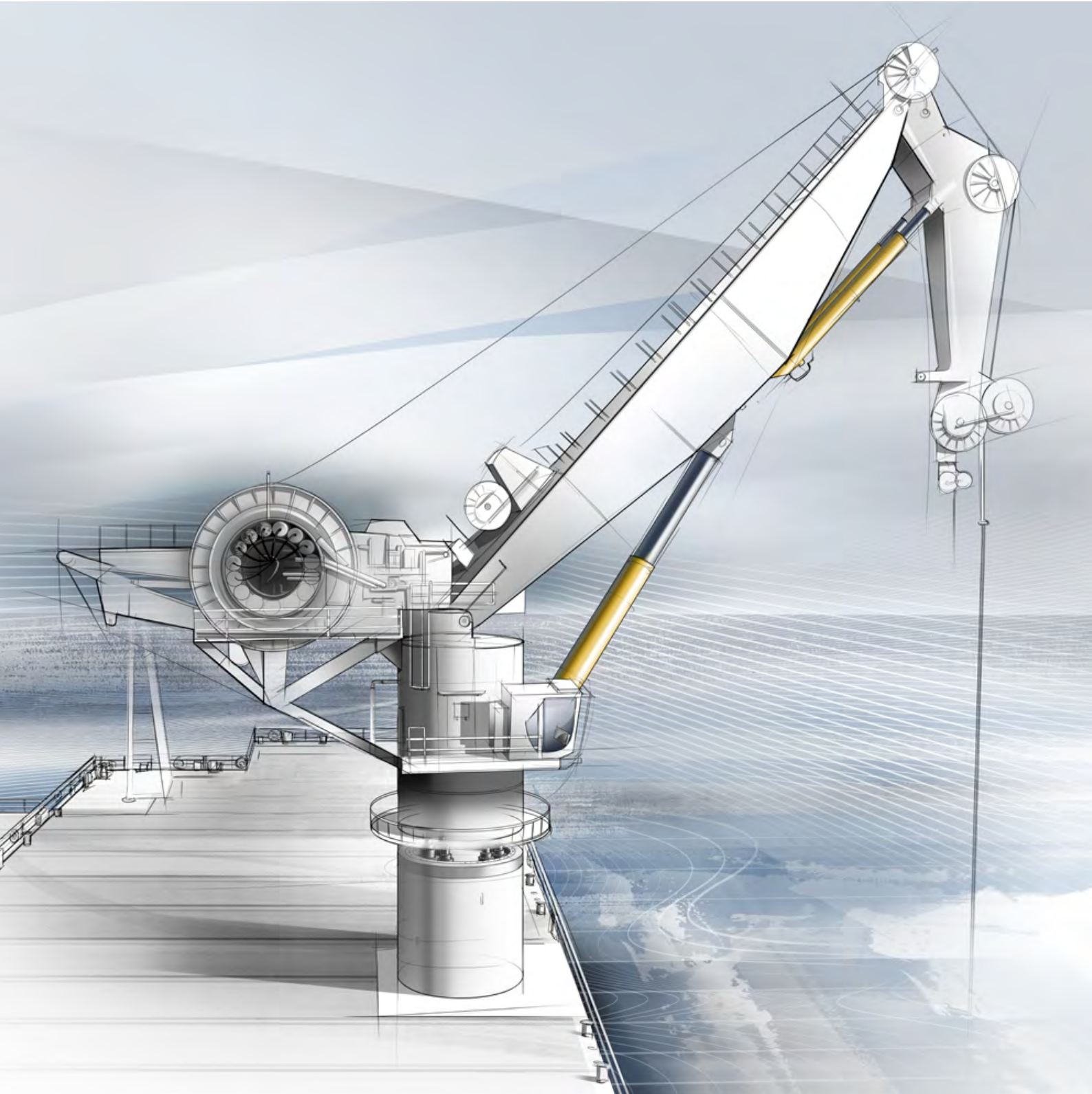

Maritime applications

Customised solutions

In the maritime industry individual solutions are sought for demanding projects. Liebherr brings comprehensive engineering know-how, project expertise and reliability. The experience of the Liebherr Group in the maritime area is the basis for products with convincing quality.

Approvals

Certification and classification by internationally recognised approval authorities serve as an external benchmark of quality for Liebherr. Partners in the maritime area include Det Norske Veritas - Germanischer Lloyd (DNV GL), Bureau Veritas, American Bureau of Shipping (ABS) and Lloyds Register of Shipping, among others.

Coating against corrosion

To respond to the rough ambient conditions in maritime environments, Liebherr has the right piston rod coating for every application. For example, nickel-chrome and fused coatings are used, which have been tried and tested in maritime applications.

Maritime paintwork

Special maritime paintwork for tough corrosion protection rounds off the individual customer solution. Here the customers benefit from the many years of experience within the Liebherr Group.

Example of application

In maritime cranes luffing cylinders are responsible to raise and lower the crane boom. At the same time synchronised cylinders ensure the proper positioning of the tube gripper.

Luffing cylinders

Liebherr offers tailor-made luffing cylinders for offshore, ship and mobile harbour cranes. Components made from high-strength materials with reduced weight, which are manufactured with precision processes, satisfy the high requirements. Tubes are honed on the inside, for example.

Synchronised cylinders

Synchronised cylinders are used for adjusting the horizontal position in diverse applications. In the maritime environment special piston rod coatings provide optimal protection against corrosion.



Examples of use

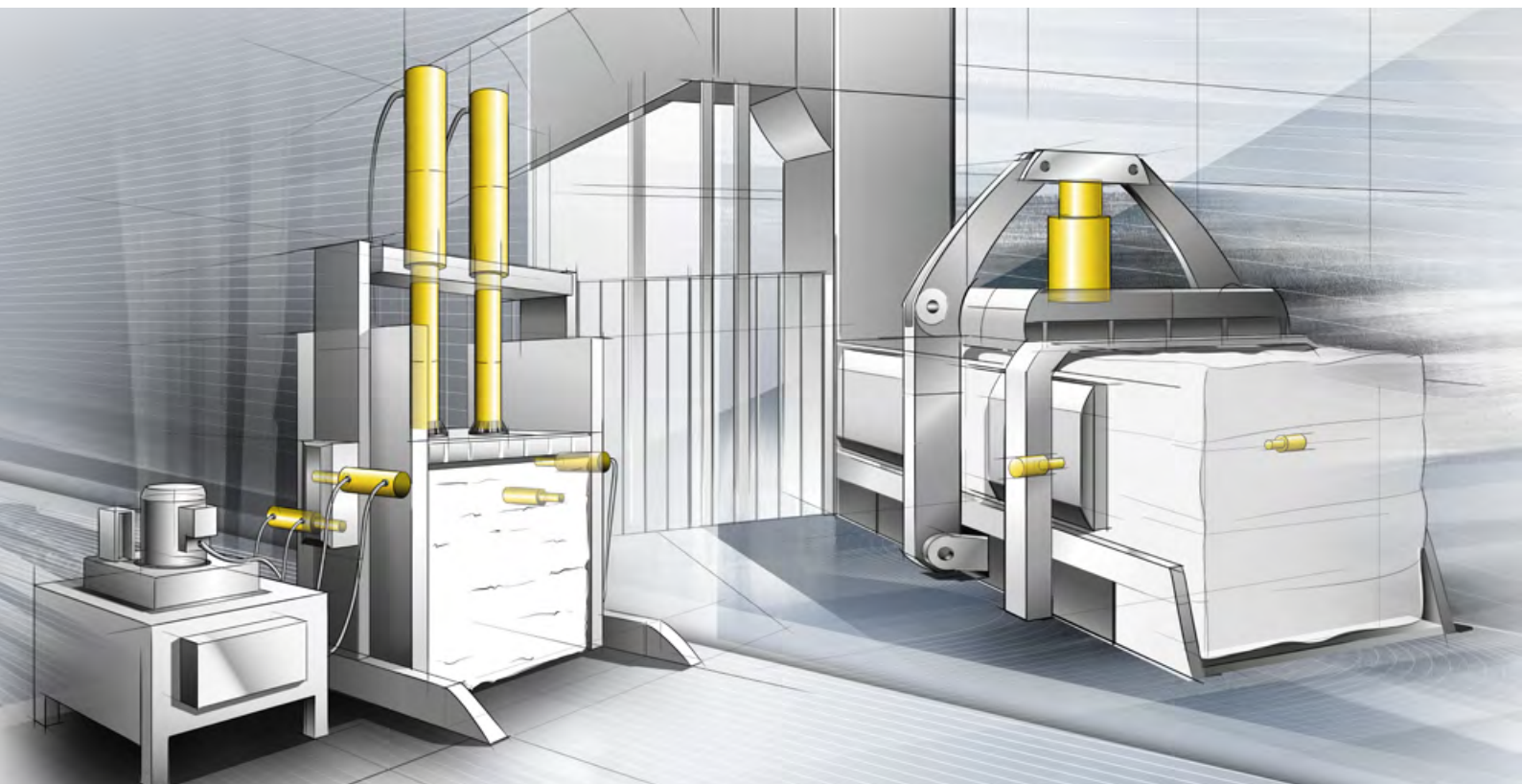
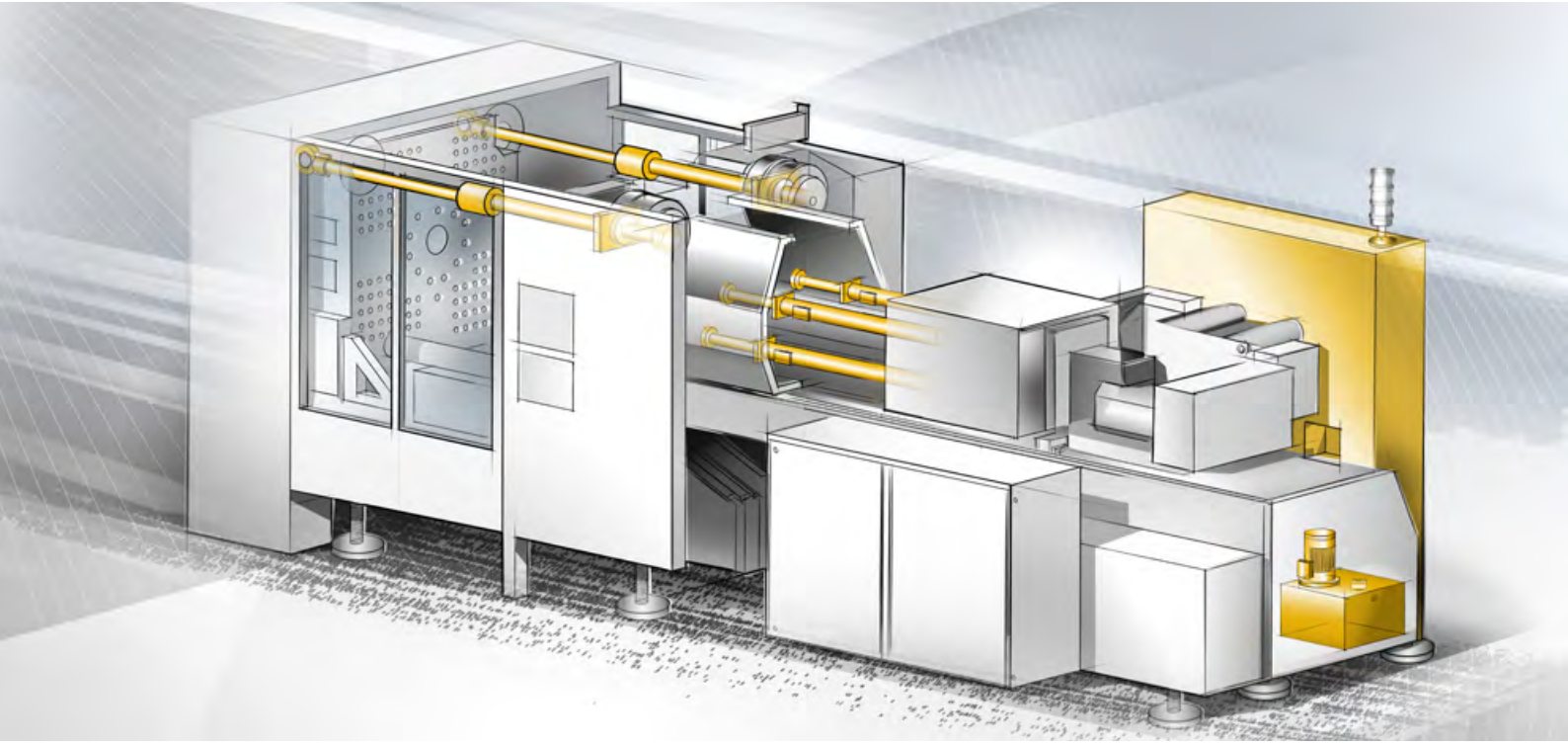

Machinery and plant construction

Diverse and flexible ranges

For machinery and plant construction Liebherr develops tailor-made solutions according to the specific requirements of the customer. For quick availability and simple integration Liebherr offers two standard ranges for such applications with which cylinders can be quickly and easily configured. The industry series follows the guidelines of the ISO 6022 standard. However, it offers highest flexibility for the cylinder configuration with a wide range of additional options. Furthermore, the 260 bar series-production range provides appropriate solutions for stationary applications. Hydraulic cylinders from Liebherr are not only designed to be easy to maintain, but are also optimised for minimal friction and wear. A compact design and clever detail solutions also contribute to the quality of the cylinders.

Individual equipment

Liebherr offers a suitable choice for every environmental situation from the wide range of available piston rod coatings. In addition to electronic position transducers, hydraulic cylinders can also be equipped with compatible clamping units and other sensors.

Drive cylinders for injection moulding machines

Drive cylinders are responsible for moving tools. In the screwed design, the cylinders are suitable for applications with high speed and high availability.



Hydraulic power units

With the application-specific design of the hydraulic power units, Liebherr guarantees the reliable hydraulic supply of stationary plants.



Liebherr Components

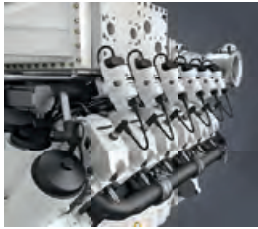

Gas engines

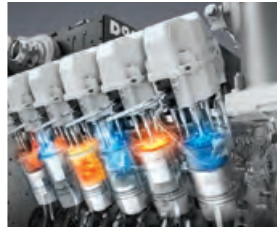

Diesel engines



Fuel injection systems



Axial piston hydraulics



Hydraulic cylinders



Slewing bearings



Gearboxes and winches

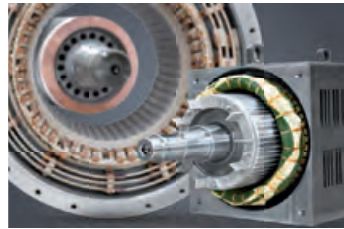

Electric machines

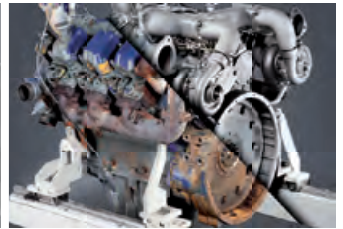

Remanufacturing



Human-machine interfaces and gateways



Control electronics and sensor technology



Power electronics



Control cabinets



Software

From A to Z – the components division of the Liebherr Group offers a broad range of solutions in the area of mechanical, hydraulic, electric and electronic drive system and control technology. The efficient components and systems are produced at a total of ten production sites around the world to the highest standards of quality. Central contact persons for all product lines are available to our customers at Liebherr-

Components AG and the regional sales and distribution branches.

Liebherr is your partner for joint success: from the product idea to development, manufacture and commissioning right through to customer service solutions like remanufacturing.

components.liebherr.com