L 524 – L 580

LIEBHERR

Wheel loaders



Generation

5

Tipping load

7,500 kg–18,950 kg

Diesel engine

Stage II

Stage IIIA (compliant)

Bharat Stage IV (India)

NR China IV

Stage V

Performance

Powerful and efficient –
for the highest level of performance

Economy

Resource-saving like no other –
constantly reducing operating costs

Reliability

Durability and dependability –
quality down to the last detail

Comfort

Perfection at a glance –
when technology enables safety and comfort

Maintainability

Time and cost savings –
thanks to simple maintenance



L 524

Tipping load, articulated
7,500 kg
Bucket capacity
2.0 m³
Operating weight
10,400 kg
Engine output
86 kW / 117 HP

L 538

Tipping load, articulated
9,500 kg
Bucket capacity
2.5 m³
Operating weight
12,800 kg
Engine output
104 kW / 141 HP



L 550

Tipping load, articulated
12,430 kg
Bucket capacity
3.4 m³
Operating weight
17,750 kg
Engine output
168 kW / 228 HP

L 566

Tipping load, articulated
15,900 kg
Bucket capacity
4.2 m³
Operating weight
23,450 kg
Engine output
200 kW / 272 HP

L 580

Tipping load, articulated
18,950 kg
Bucket capacity
5.2 m³
Operating weight
26,950 kg
Engine output
219 kW / 298 HP

Performance



Powerful and efficient – for the highest level of performance

The innovative Liebherr driveline considerably increases working efficiency. Quick loading cycles, high tipping loads and high machine availability lead to increased handling capacity.



Reliable and powerful performance

- Strong construction and rugged steel components are perfectly adapted to each other
- Remove regulation of acceleration without noticeable gear shifts or interruption in tractive force



Lift arm variants optimised for every application

- Z-bar linkage for high torque in the lower lifting range of the lift arm – simple, quick filling of the bucket leads to high handling capacity
- Parallel linkage for L 524 – L 538 or industrial linkage for L 550 – L 580 have especially high torque in the upper lifting range



Wide range of applications

- Multitude of uses can easily be covered thanks to the variety of robust buckets from Liebherr
- Optimized high lift lift arm for improved discharge heights for high boardwall sides

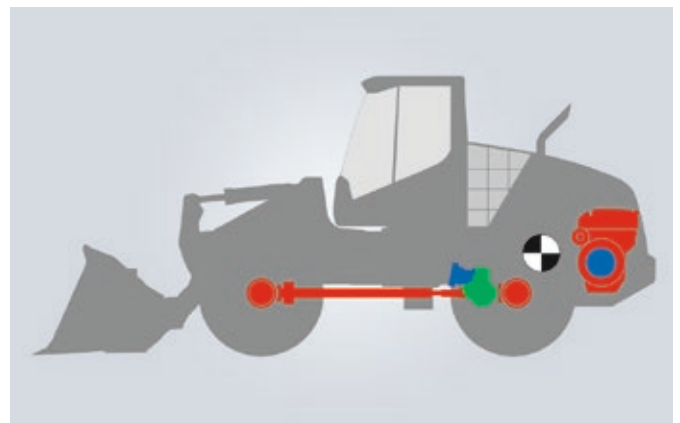

Higher productivity at lower weight

- Components act as counterweight
- L 524 – L 550 transverse-mounted diesel engine
- L 566 – L 580 longitudinally-mounted diesel engine, output shaft faces the rear
- Higher tipping loads at lower operating weight

Economy



Resource-saving like no other – constantly reducing operation costs

Liebherr wheel loaders are designed with the customer in mind. The fuel-efficient drive concept reduces operating costs and environmental impact at maximum handling capacity. The hydrostatic drive, combined with automatic limited slip differential, delivers excellent traction while also preventing wheel spin. Productivity is increased and tyre wear reduced.



Lower fuel consumption

- Liebherr driveline achieves a reduction in fuel consumption of up to 25%
- Noticeable reduction in operating costs
- Lower fuel consumption cuts emissions, protecting the environment



Hardly any brake wear

- Liebherr driveline brakes automatically
- Service brake acts as an additional support
- Very low wear and tear



Minimal tyre wear

- Continuous tractive force, combined with automatic limited slip differential, prevents wheelspin
- Productivity is increased
- Tyre wear reduced by up to 25%



Efficient management with LiDAT:

- Evaluation of machine usage and fuel consumption for economic machine and fleet management
- All important machinery data can be viewed in a web browser
- LiDAT comes as standard incl. 1 year free-of-charge use

Reliability



Durability and sustainability – quality down to the last detail

Liebherr wheel loaders provide maximum performance even under the toughest of operating conditions. Specially-developed components, sophisticated technology and high quality materials offer a high level of reliability and availability. The intelligent cooling system guarantees continuous cooling output while simultaneously reducing cleaning expenses, resulting in more efficient and cost-effective work.



Strong components ensure a long lifetime

- Many decades of experience in the development, construction and production of components
- Ideal interaction of components to each other for maximum performance
- Maximum quality even under the toughest operating conditions
- Rugged, durable machines for reliable operations



Intelligent cooling system

- Cooling system located in the cleanest area of the wheel loader
- High machine availability thanks to lower radiator contamination
- Controlled cooling through thermostatic control for reliable operations



Optional equipment for dusty applications

- Reversible fan drive, fluff trap for the radiator and largemesh radiator ensures the cooling system stays free of contaminants
- Guarantees continuous cooling output
- Reduces cleaning expenses

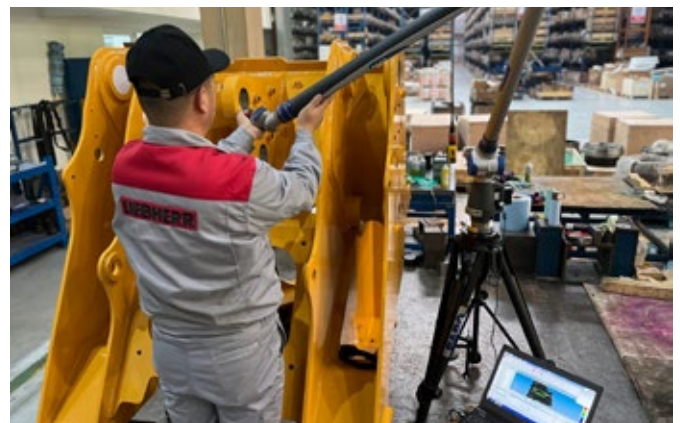

Highest quality for durable machines

- Liebherr stands for the highest quality down to the smallest detail and guarantees longlasting machines thanks to outstanding engineering and decades of experience
- Thanks to continuous further process improvement, the use of the latest technologies in development and production, and compliance with the latest standards, Liebherr offers engineering at the highest level

Comfort



Perfection at a glance – when technology is comfortable and safe

The more comfortable the operator, the more productive the work. The cab design is optimally adapted to the operator's day-to-day requirements. Roomy and ergonomic, the operators cab offers perfect conditions for safe, comfortable, and productive work.



Exceptional all-around visibility

- Unobstructed visibility in all directions through optimal cab and engine hood design
- Impressive glass surfaces offer exceptional all-around visibility of the attachment and working area
- Optional rear view camera
- Maximum safety, for persons both in and around the machine, as well as for the machine and load itself - while also increasing productivity



Ergonomic cab

- Modern, ergonomic cab design maintain a high degree of concentration, while minimizing fatigue
- Carefully coordinated displays, controls, and operator's seating position form an ergonomic unit
- Optimum storage areas and stowage spaces increase operator well-being
- Air conditioning system as standard ensures a pleasant temperature year-round



Liebherr control lever

- Simple, intuitive and ergonomic operation
- Control operating manoeuvres with a single control lever
- Precise, sensitive and safe control of the machine
- Left hand can always remain on the steering wheel - increases safety at the job site
- Proportional control of hydraulic attachments is carried out by the Liebherr control lever with mini-joystick, which is optional for L 566 - L 580



More comfort due to technology

- Programmable automatic lifting and lowering
- Automatic & programmable bucket return-to-dig
- Lifting frame cylinder stroke limit damping
- Bucket tilt assist
- Dump speed reduction
- Weighing system functions automatically and intelligently, with dynamic weighing area adjustment
- "Truck Payload Assist" ensures precise and efficient loading

Maintainability



Time and cost savings – through simple maintenance

The most important points for daily maintenance of Liebherr wheel loaders can be reached safely and conveniently from one point. Quick and safe checks save time and money.



Efficient and simple maintenance

- Well thought-out component installation positioning provides excellent accessibility for maintenance
- Less contamination of the radiator thanks to its clever position behind the operator's cab
- Quick and safe checks saves time and money



Optimum service accessibility

- Most access points for daily maintenance are accessible via just one enclosure
- The most important points for daily care can be easily reached from one point
- Short downtimes leads to more efficiency



Trustworthy partnership with strong service

- Optimum service and quick replacement part provision due to a robust service network and a highly-modern central warehouse
- Quick and reliable service carried out by qualified service specialists
- Speed-optimized servicing increases the availability and profitability of the machine



Extended warranties and service packages

- Extended powertrain and full-machine warranties available from the manufacturing plant to the sales partner
- Three different levels of "CarePack" service packages, Service, Comfort, and Premium, offer even more ease of maintenance

Wheel loaders

L 524 – L 580 overview

Equipment

Equipped for every application – Liebherr offers three lift arm versions for the new model. The z-bar kinematics, which come to the fore particularly in the lower lifting range and for the break out force. Secondly, the industrial kinematics for working with heavy working tools such as high dump buckets and log grapplers. And the high lift lift arms – an extended version of the z-bar kinematics with the longest lift arms in this wheel loader segment. These ensure greater reach and more productive loading procedures at great heights.



Liebherr driveline

Powerful and efficient – Thanks to increases in engine power the travel drive is even more powerful while maintaining the same low fuel consumption. The diesel engine is installed in the rear, where it acts as a counterweight thereby increasing the tip load for the wheel loaders. The continuous traction control, combined with automatic self-locking differential, prevents wheelspin and saves tyre wear.



Operator's cab

Excellent all-round visibility – The clean lines on the rear as well as the large glass surfaces in the cab facilitate a perfect view. The new reversing camera assists the machine operator to keep an eye on the area to the rear. This increases performance and productivity and ensure an easy and safe operation. The Liebherr control lever enables the highly-sensitive control work movements as part of the modern operating concept which includes also a height-adjustable 9-inch touch display with intuitive menu navigation.

Intelligent cooling system

Clean and clever – A perfect located radiator ensures a high machine availability through minimal cleaning expenses. It is installed directly behind the operator's cab – the cleanest position on the wheel loader – this increases the service life of the components and ensure a constant and reliable cooling.

Service accessibility

Simple, safe and fast – Numerous details that have been seamlessly integrated in the wheel loaders' exterior design make service work easier and safes time in daily maintenance. This ensures short service times for more productivity. In addition to that LiDAT offers a perfect fleet park management for machinery data recording and diagnostics and is available ex factory.

Technical data

L 524-L 538



Diesel engine

	L 524	L 538
Diesel engine	4045HF286	4045HF286
Design	Water-cooled, turbo charged, intercooled	
Cylinder inline	4	
Fuel injection process	Electronic Common Rail high-pressure injection	
Max. gross output		
to ISO 3046		
and SAE J1995	kW/HP 86/117	104/141
at RPM	2,200	2,200
Max. net output		
to ISO 9249		
and SAE J1349	kW/HP 85/116	102/139
at RPM	2,200	2,200
Rated output		
to ISO 14396	kW/HP 86/117	104/141
at RPM	2,400	2,400
Max. net torque to		
ISO 9249 and SAE J1349	Nm 416	508
at RPM	1,400	1,400
Displacement	litres 4.5	
Bore / Stroke	mm 106 / 127	
Stage IIIA (compliant)		
Harmful emissions values	According to regulation ECE-R.96 Power Band H	
Air cleaner system	Dry air filter with main and safety element, pre-cleaner, service indicator	
Electrical system		
Operating voltage	V 24	
Battery	Ah 2 x 135	
Alternator	V/A 28 / 100	
Starter	V/kW 24 / 7	



Driveline

Continuous hydrostatic driveline

Design	Swash plate type variable flow pump and two variable axial piston motors in closed loop circuit and axle transfer case. Direction of travel is reversed by changing the flow-direction of the variable-displacement pump
Filtration	Suction return line filter for closed circuit
Control	By travel and inching pedal. The inching pedal makes it possible to control the tractive and thrust forces steplessly at full engine speed. The Liebherr control lever is used to control forward and reverse travel
Travel speed range	Speed range 1 _____ 0- 4 km/h Speed range A1-2 _____ 0-15 km/h Speed range A1-3 _____ 0-40 km/h* forward and reverse Speeds quoted apply with the tyres indicated as standard on loader model.

* Configuration, tyres and mounting tools can influence the maximum speed.



Brakes

Wear-free service brake

Self-locking of the hydrostatic driveline (acting on all four wheels) and additional pump-accumulator brake system with wet multi-disc brakes located in the differential housing (two separate brake circuits)

Parking brake

Electro-hydraulically actuated spring-loaded disc brake system on the front axle

The braking system meets the requirements of the ISO 3450.



Tyres

Standard size L 524	17.5R25 L3
Standard size L 538	20.5R25 L3
Special tyres	By arrangement with the manufacturer

L 524

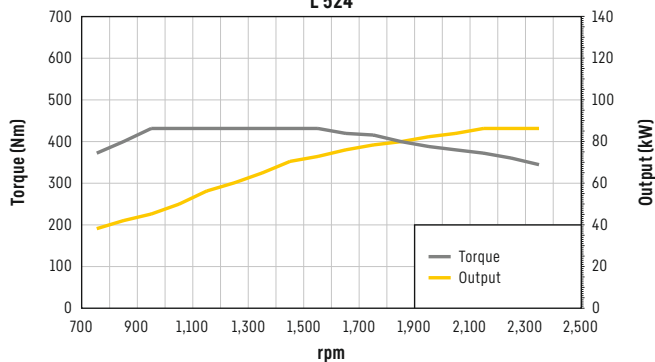

L 538

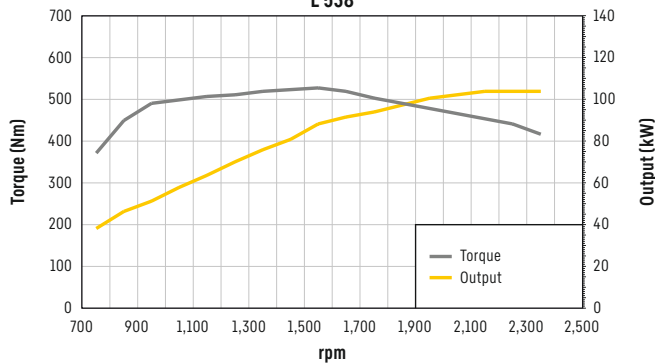

Axles

	L 524	L 538
Four-wheel drive		
Front axle	Fixed	
Rear axle	Centre pivot, with 10° oscillating angle to each side	
Height of obstacles which can be driven over	mm	470
	with all four wheels remaining in contact with the ground	
Differentials	Automatic limited-slip differentials	
Reduction gear	Planetary final drive in wheel hubs	
Track width	1,960 mm with all types of tyres (L 524) 1,900 mm with all types of tyres (L 538)	

Steering

Design	"Load-sensing" swash plate type variable flow pump with pressure cut-off and flow control. Central pivot with two double-acting steering cylinders
Angle of articulation	40° to each side
Emergency steering	Electro-hydraulic emergency steering system, optional

Attachment hydraulics

	L 524	L 538
Design	"Load-sensing" swash plate type variable flow pump with output and flow control, and pressure cut-off in the control block	
Cooling	Hydraulic oil cooling using thermostatically controlled fan and oil cooler	
Filtration	Return line filter in the hydraulic reservoir	
Control	Liebherr control lever with hydraulic servo control	
Lifting function	Lifting, neutral, lowering Float position controlled by Liebherr control lever with detent	
Tilt function	Tilt back, neutral, dump Automatic bucket return to dig as standard	
Max. flow	l/min.	102
Max. pressure	bar	315

Attachment

	L 524	L 538
Geometry variants	Optional	
	Powerfull Z-bar linkage with tilt cylinder and steel cross-tube Parallel linkage with two tilt cylinders and steel cross-tube	
Bearings	Sealed	
Cycle time at nominal load	ZK	PK
Lifting	s	6.6
Dumping	s	1.8
Lowering (empty)	s	4.0

Operator's cab

Design	Elastic mounted, noise-proof cab ROPS roll over protection per EN ISO 3471 / EN 474-1 FOPS falling objects protection per EN ISO 3449 / EN 474-1, Cat. II. Operator's door with 105° opening angle, ventilation opening on the right hand side, front windscreen made of laminated safety glass, green tinted as standard, side panels with single-pane safety glass, grey tinted, heated rear window. Continuously adjustable steering column and joystick control as standard
Liebherr operator's seat	6 way adjustable, vibration-damped operator's seat "Standard" (mechanically sprung, adjustable to operator's weight)
Cab heating and ventilation	4-level air control, cooling water heating, mechanical controlled heating and air conditioning system as standard

Sound level

	L 524	L 538
Sound pressure level to ISO 6396		
L _{pA} (inside cab)	dB(A)	69
Sound power level to 2000/14/EC		
L _{WA} (surround noise)	dB(A)	102

Capacities

	L 524	L 538
Fuel tank	l	225
Engine oil (inclusive filter change)	l	14.7
Transmission	l	3.8
Coolant	l	36
Front axle	l	16.3/2.6
Rear axle	l	15/2.6
Hydraulic tank	l	110
Hydraulic system, total	l	170

Dimensions

Excavation bucket (Z-bar linkage)

L 524-L 538

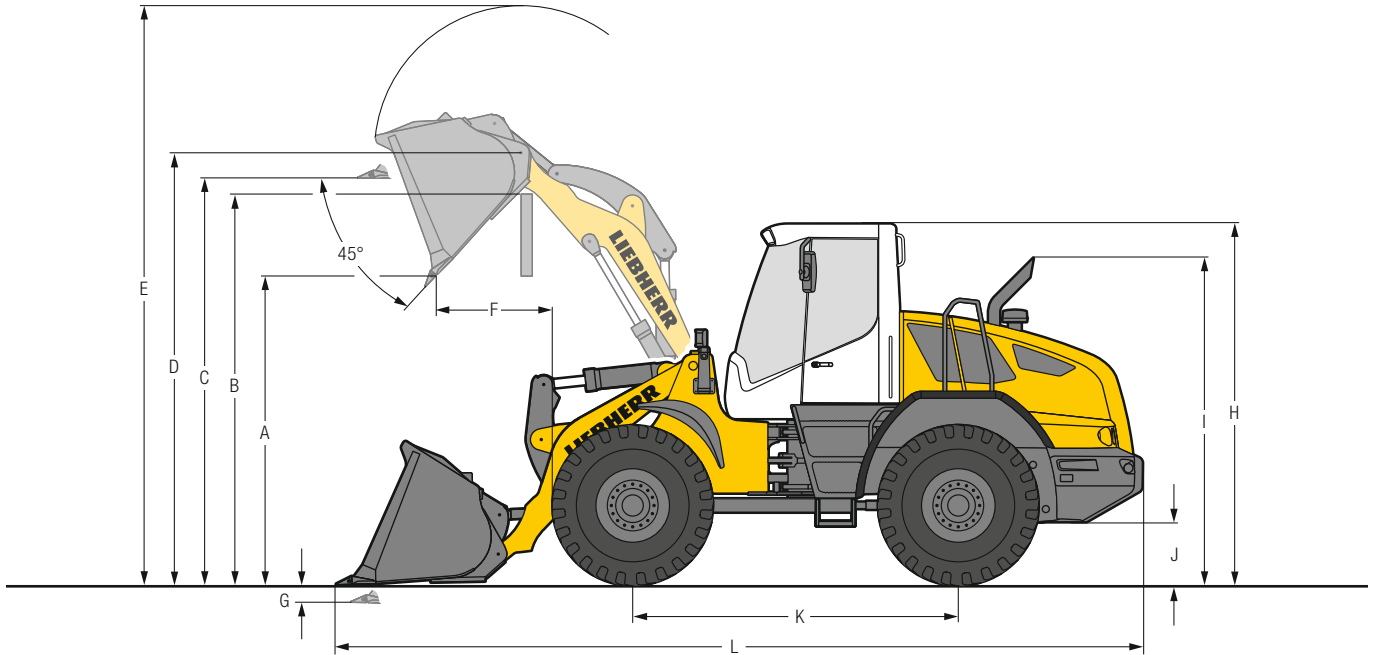

Excavation bucket

	L 524		L 538		
	ZK	ZK-QC	ZK	ZK	ZK-QC
Geometry					
Cutting tools	T	T	T	T	T
Lift arm length	mm	2,400	2,500	2,500	2,500
Bucket capacity according to ISO 7546**	m ³	2.0	1.7	2.5	2.2
Specific material density	t/m ³	1.8	1.8	1.8	1.8
Bucket width	mm	2,500	2,500	2,500	2,500
A Dumping height at max. lift height and 45° discharge	mm	2,870	2,765	2,900	2,845
B Dump-over height	mm	3,335	3,320	3,480	3,475
C Max. height of bucket bottom	mm	3,530	3,530	3,680	3,680
D Max. height of bucket pivot point	mm	3,775	3,775	3,930	3,930
E Max. operating height	mm	4,860	4,915	5,170	5,260
F Reach at max. lift height and 45° discharge	mm	850	900	960	1,005
G Digging depth	mm	80	80	80	80
H Height above operator's cab	mm	3,200	3,200	3,250	3,250
I Height above exhaust	mm	2,860	2,860	2,910	2,910
J Ground clearance	mm	460	460	490	490
K Wheelbase	mm	2,850	2,850	2,975	2,975
L Overall length	mm	6,820	6,935	7,150	7,225
Turning circle radius over tyres	mm	5,170	5,170	5,350	5,350
Turning circle radius over outside bucket edge	mm	5,690	5,720	5,840	5,880
Width over tyres	mm	2,460	2,460	2,470	2,470
Breakout force (SAE)	kN	91	85	117	114
Tipping load, straight*	kg	8,500	7,900	10,700	10,500
Tipping load, fully articulated*	kg	7,500	7,000	9,500	9,300
Operating weight*	kg	10,400	10,800	12,800	13,000
Tyre size		17.5R25 L3		20.5R25 L3	

* The figures shown here are valid with tyres above (optional tyres will change the vertical dimensions), includes all lubricants, a full fuel tank, the ROPS / FOPS cab and the operator. Different tyres and optional equipment will change the operating weight and tipping load. (Tipping load, fully articulated according to ISO 14397-1)

** Actual bucket capacity may be approx. 10% larger than the calculation according to ISO 7546 standard. The degree to which the bucket can be filled depends on the material - see page 22.

ZK = Z-bar linkage

ZK-QC= Z-bar linkage incl. quick coupler

T = Welded-on tooth holder with add-on teeth

Attachment

Light material bucket (Z-bar linkage)

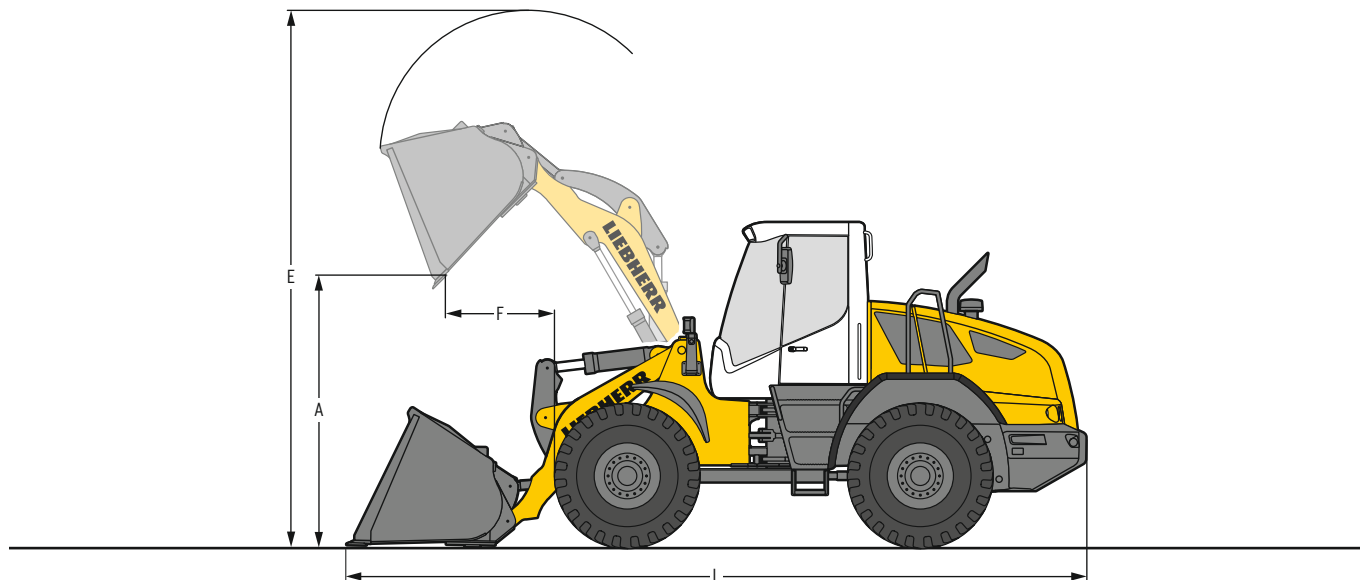

Light material bucket

	L 524				L 538		
	ZK	ZK	ZK	ZK-QC	ZK	ZK	ZK-QC
Geometry							
Cutting tools	BOCE	BOCE	BOCE	BOCE	BOCE	BOCE	BOCE
Bucket capacity	m ³ 2.4	3.0	4.0	4.0	3.5	4.0	4.0
Specific material density	t/m ³ 1.0	0.8	0.5	0.5	1.0	0.8	0.8
Bucket width	mm 2,500	2,500	2,700	2,700	2,700	2,700	2,700
A Dumping height at max. lift height	mm 2,755	2,640	2,490	2,370	2,730	2,715	2,520
E Max. operating height	mm 5,025	5,160	5,300	5,430	5,360	5,440	5,590
F Reach at maximum lift height	mm 990	1,110	1,260	1,300	1,140	1,300	1,285
L Overall length	mm 7,345	7,130	7,340	7,410	7,360	7,695	7,700
Tipping load, straight*	kg 8,450	8,260	7,970	7,370	10,420	10,190	9,520
Tipping load, fully articulated*	kg 7,450	7,290	7,040	6,510	9,190	9,000	8,390
Operating weight*	kg 10,850	10,980	11,105	11,290	13,180	13,300	13,470
Tyre size	17.5R25 L3				20.5R25 L3		

* The figures shown here are valid with tyres above (optional tyres will change the vertical dimensions), includes all lubricants, a full fuel tank, the ROPS / FOPS cab and the operator. Different tyres and optional equipment will change the operating weight and tipping load. (Tipping load, fully articulated according to ISO 14397-1)

ZK = Z-bar linkage

ZK-QC = Z-bar linkage incl. quick coupler

BOCE = Bolt-on cutting edge

Dimensions

Light material bucket (parallel linkage)

L 524-L 538

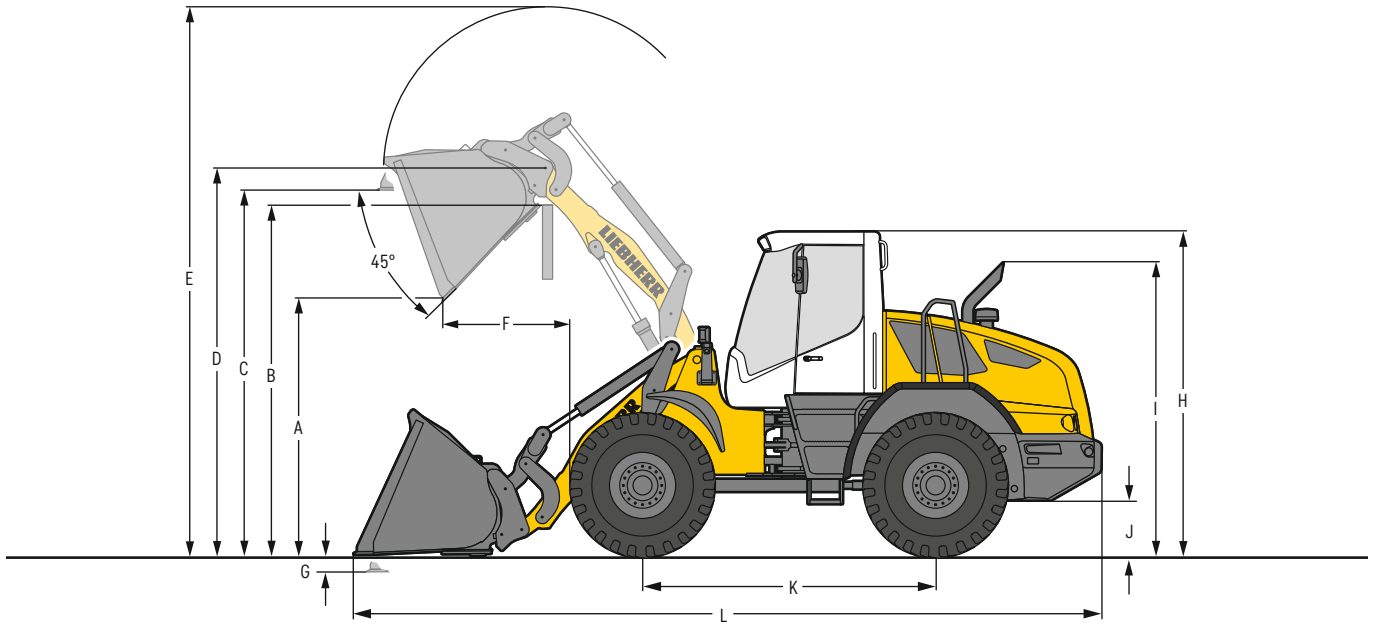

Light material bucket

	L 524		L 538	
	PK-QC	PK-QC	PK-QC	PK-QC
Geometry	PK-QC	PK-QC	PK-QC	PK-QC
Cutting tools	BOCE	BOCE	BOCE	BOCE
Lift arm length	mm	2,500	2,500	2,500
Bucket capacity according to ISO 7546**	m ³	3.0	5.5	4.0
Specific material density	t/m ³	1.0	0.5	1.0
Bucket width	mm	2,750	2,750	2,750
A Dumping height at max. lift height and 45° discharge	mm	2,630	2,230	2,520
B Dump-over height	mm	3,380	3,380	3,430
C Max. height of bucket bottom	mm	3,595	3,595	3,645
D Max. height of bucket pivot point	mm	3,835	3,835	3,890
E Max. operating height	mm	5,290	5,670	5,460
F Reach at max. lift height and 45° discharge	mm	1,220	1,630	1,300
G Digging depth	mm	55	55	35
H Height above operator's cab	mm	3,200	3,200	3,250
I Height above exhaust	mm	2,860	2,860	2,910
J Ground clearance	mm	460	460	490
K Wheelbase	mm	2,850	2,850	2,975
L Overall length	mm	7,355	7,930	7,765
Turning circle radius over tyres	mm	5,170	5,170	5,350
Turning circle radius over outside bucket edge	mm	5,765	5,930	6,070
Width over tyres	mm	2,460	2,460	2,470
Breakout force (SAE)	kN	63	63	87
Tipping load, straight*	kg	7,920	7,330	9,900
Tipping load, fully articulated*	kg	6,980	6,470	8,730
Operating weight*	kg	11,800	12,200	13,600
Tyre sizes		17.5R25 L3		20.5R25 L3

* The figures shown here are valid with tyres above (optional tyres will change the vertical dimensions), includes all lubricants, a full fuel tank, the ROPS/FOPS cab and the operator. Different tyres and optional equipment will change the operating weight and tipping load. (Tipping load, fully articulated according to ISO 14397-1)

** Actual bucket capacity may be approx. 10% larger than the calculation according to ISO 7546 standard. The degree to which the bucket can be filled depends on the material – see page 22.

PK-QC = Parallel linkage incl. quick coupler
BOCE = Bolt-on cutting edge

Attachment

Fork carrier and fork

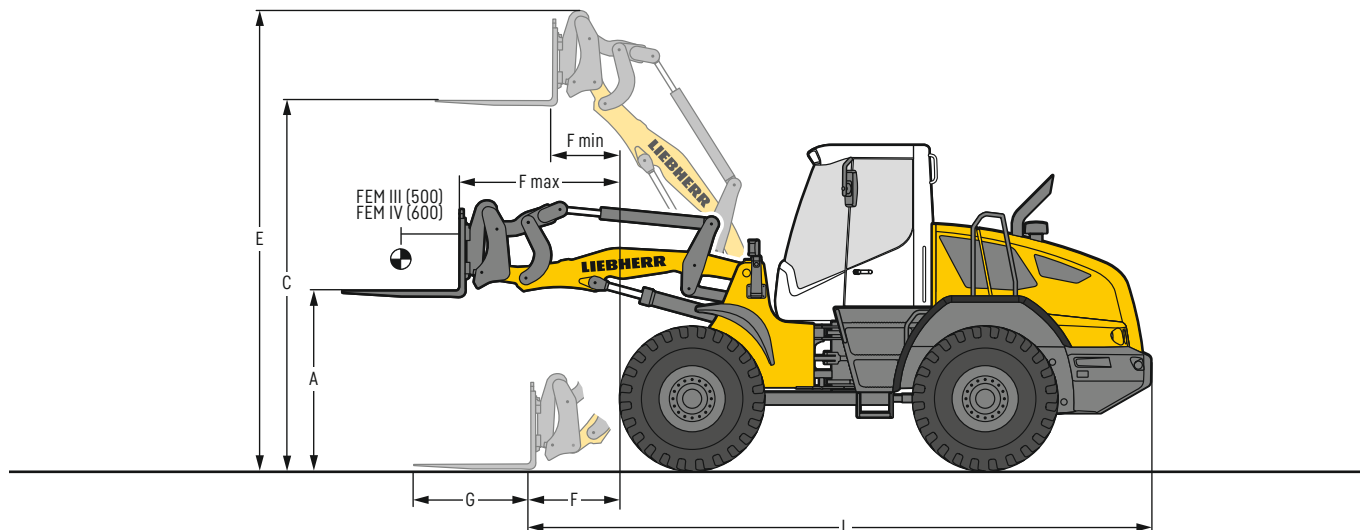

FEM III fork carrier and fork

Geometry		L 524		L 538		
		ZK-QC	PK-QC	ZK-QC	PK-QC	
A	Lifting height at max. reach	mm	1,690	1,690	1,781	1,739
C	Max. lifting height	mm	3,580	3,645	3,738	3,697
E	Max. operating height	mm	4,510	4,560	4,662	4,612
F	Reach at loading position	mm	975	1,110	939	975
F max.	Max. reach	mm	1,625	1,720	1,635	1,635
F min.	Reach at max. lifting height	mm	695	780	694	695
G	Fork length	mm	1,200	1,200	1,200	1,200
L	Length - basic machine	mm	6,190	6,325	6,350	6,390
	Tipping load, straight *	kg	6,000	6,480	7,880	8,150
	Tipping load, fully articulated *	kg	5,300	5,700	6,940	7,200
	Recommended payload for uneven ground = 60% of tipping load, articulated ¹⁾	kg	3,180	3,420	4,150	4,320
	Recommended payload for smooth surfaces = 80% of tipping load, articulated ¹⁾	kg	4,010 ³⁾	4,580	5,000 ²⁾	5,000 ³⁾
	Operating weight*	kg	10,600	11,260	12,700	12,900
	Tyre size		17.5R25 L3		20.5R25 L3	

* The figures shown here are valid with tyres above (optional tyres will change the vertical dimensions), includes all lubricants, a full fuel tank, the ROPS/FOPS cab and the operator. Different tyres and optional equipment will change the operating weight and tipping load. (Tipping load, fully articulated according to ISO 14397-1)

¹⁾ According to EN 474-3

²⁾ Load capacity for the fork carrier and forks is limited to 5,000 kg

³⁾ Payload on forks is limited by tilt cylinder

ZK-QC = Z-bar linkage incl. quick coupler

PK-QC = Parallel linkage incl. quick coupler

Bucket selection

L 524-L 538

L 524

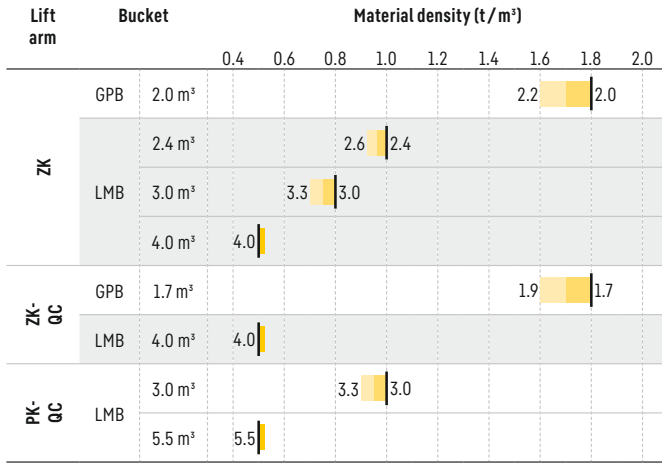

L 538

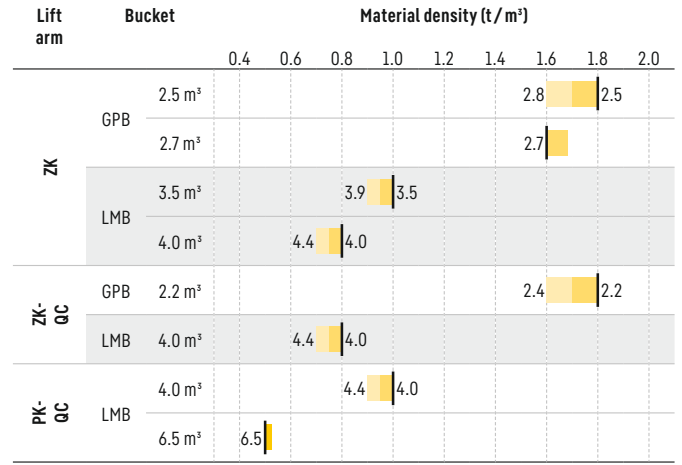

Bucket filling factor

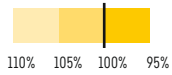

Lift arm

ZK	Z-bar linkage, standard lift arm length
ZK-QC	Z-bar linkage, with quick coupler, standard lift arm length
PK-QC	Parallel linkage with quick coupler, standard lift arm length

Bucket

GPB	General purpose bucket (Excavation bucket)
LMB	Light material bucket

Bulk material densities and bucket filling factors

		t/m³	%			t/m³	%			t/m³	%
Gravel	moist	1.9	105	Earth	dry	1.3	115	Glass waste	Wastebroken	1.4	100
	dry	1.6	105		wet excavated	1.6	110		solid	1.0	100
	crushed stone	1.5	100	Topsoil		1.1	110	Compost	dry	0.8	105
Sand	dry	1.5	105	Basalt		1.95	100	wet	1.0	110	
	wet	1.9	110	Granite		1.8	95	Wood chips / Saw dust		0.5	110
Gravel and Sand	dry	1.7	105	Sandstone		1.6	100	Paper	shredded / loose	0.6	110
	wet	2.0	100	Slate		1.75	100		recovered paper / cardboard	1.0	110
Sand / Clay		1.6	110	Bauxite		1.4	100	Coal	heavy material density	1.2	110
Clay	natural	1.6	110	Limestone		1.6	100		light material density	0.9	110
	dry	1.4	110	Gypsum	broken	1.8	100	Waste	domestic waste	0.5	100
Clay / Gravel	dry	1.4	110	Coke		0.5	110		bulky waste	1.0	100
	wet	1.6	100	Slag	broken	1.8	100				

Equipment



Basic wheel loader

	L 524	L 538
Crash protection, rear	+	+
Automatic central lubrication system	+	+
Battery main switch (lockable)	●	●
Ride control	+	+
Parking brake	●	●
Fluff trap for radiator	+	+
Speed limiter V_{MAX} , adjustable key on the control unit	●	●
Pre-heat system for cold starting	●	●
Rear license panel light	+	+
Combined inching-braking system	●	●
Steel mudguard	●	●
Steel fuel tank	●	●
Fuel pre-filter	●	●
Fuel pre-filter with pre-heating	●	●
Large-mesh radiator	+	+
Cooling water pre-heating 230 V	+	+
Multi-disc limited slip differentials in both axles	●	●
Reversible fan drive	+	+
Headlights rear, single design (on tail flap), halogen	●	●
Auxiliary heater (Additional heating with engine preheating)	+	+
Lockable doors and engine hood	●	●
Chassis protection rear	+	+
Chassis protection front	+	+
Chock	+	+
Air pre-cleaner TOP SPIN	+	+
Toolbox with toolkit	●	●
Towing hitch	●	●



Equipment

	L 524	L 538
Working hydraulics lockout	●	●
Automatic hoist kick-out – adjustable	+	+
Automatic bucket return – adjustable	●	●
Fork carrier and pallet forks	+	+
High-dump bucket	+	+
Log grapple	+	+
High Lift arms	-	-
Industrial lift arm	-	-
Lift arm parallel linkage	+	+
Lift arm Z-bar linkage	●	●
Hydraulic quick coupler	+	+
Tilt cylinder protection	+	+
Loading buckets incl. a range of cutting tools	+	+
Light material bucket	+	+
Pipe break protection	+	+
Float position	●	●
1st additional hydraulic function	+	+

Equipment



Operator's cab

	L 524	L 538
Exterior mirror, tiltable and adjustable	•	•
Operating hour meter (integrated in display unit)	•	•
Storage box	•	•
Operator's seat - air sprung	+	+
Operator seat "Comfort" - pneumatic suspension with seat heating	+	+
Operator seat "Standard" - mechanically sprung	•	•
Heater	•	•
Floor mat	•	•
Clothes hook	•	•
Air conditioning system	•	•
Headrest	+	+
Steering column adjustable	•	•
Liebherr control lever - adjustable	•	•
Radio Liebherr "Standard" (USB/AUX)	•	•
Interior rear-view mirror	•	•
Amber beacon swiveling / fixed	+	+
Soundproof ROPS / FOPS cab	•	•
Wipe and wash system	•	•
Headlights rear, single design, halogen	•	•
Headlights rear, double design, halogen	+	+
Headlights rear, double design, LED	-	-
Headlights front, double design, halogen	•	•
Windscreen guard	+	+
Sun visor front	•	•
Power socket 12 V	•	•
Preparation for LiDAT	+	+
Cigarette lighter	•	•



Safety

	L 524	L 538
Country-specific versions	+	+
Emergency steering system	+	+
Back-up alarm acoustic	•	•
Rear space monitoring with camera	+	+

• = Standard
 + = Option
 - = not available

Technical data

Diesel engine

		L 550		
Diesel engine - available only in select markets		Stage II	Bharat stage IV (India) / Stage V	NR China IV
		6068HB330	BS4: 6068HB450 Stage V: 6068HB551	NR China IV: 6068HB430
Design		Water-cooled, turbo charged, intercooled		
Cylinder inline		6		
Fuel injection process		Electronic Common Rail high-pressure injection		
Output to ISO 9249 ~ SAE J1349		kW / HP at RPM	161 / 219 2,400	155 / 211 2,100
Rated output to ISO 14396 / ECE-R.120		kW / HP at RPM	168 / 228 2,400	161 / 219 2,100
Nominal speed		2,400		
Max. torque to ISO 14396		Nm at RPM	890 1,600	941 1,500
Displacement		6.8 litres		
Bore / Stroke		106 / 127 mm		
Available certifications		ECE R96 E; MAR-I		
Emission control		SCR technology and closed diesel particle filter system		
Air cleaner system		Dry air filter with main and safety element, pre-cleaner, service indicator		
Electrical system				
Operating voltage		24 V		
Battery		135 Ah		
Alternator		24 / 100 V / A		
Starter		24 / 7.8 V / kW		

The availability of the models depends on the emission regulations of the respective countries.

L 550 II

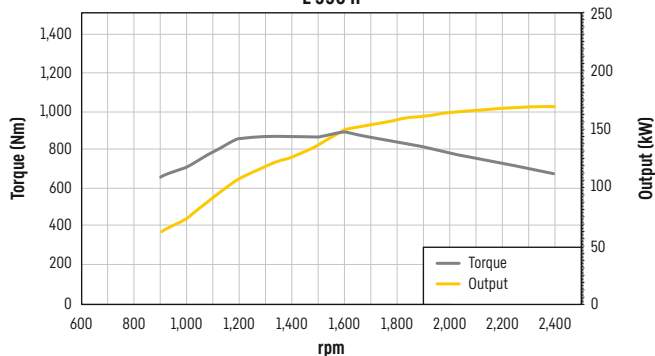

L 550 NR4

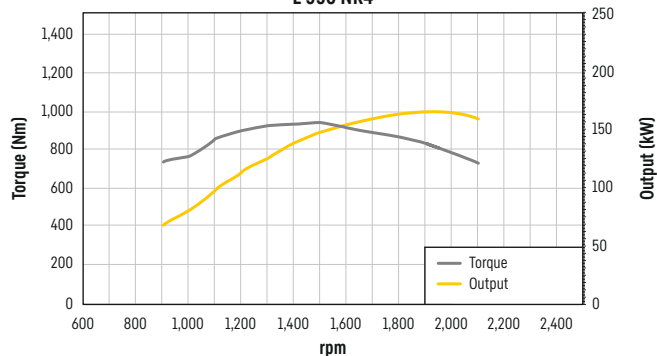

L 550 BS4 / Stage V

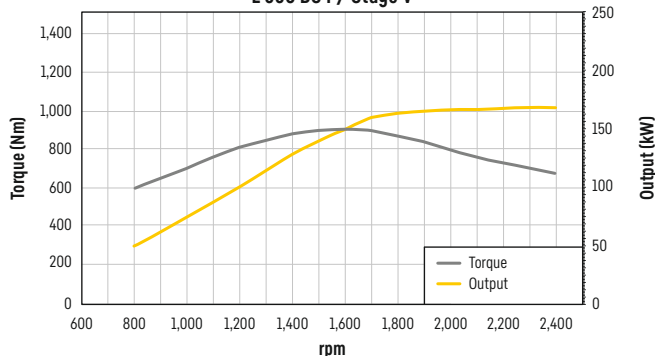

Technical data



Diesel engine

		L 566		L 580	
Diesel engine - available only in select markets		Stage II	NR China IV / Stage V	Stage II	NR China IV / Stage V
		6090HFL75	NR China IV: 6090CB451 Stage V: 6090CB550A	6090HFL75	NR China IV: 6090CB451 Stage V: 6090CB550B
Design		Water-cooled, turbo charged, intercooled			
Cylinder inline		6		6	
Fuel injection process		Electronic Common Rail high-pressure injection			
Output to ISO 9249 ~ SAE J1349		kW / HP at RPM	211 / 283 1,800	231 / 310 1,800	214 / 287 1,700
Rated output to ISO 14396 / ECE-R.120		kW / HP at RPM	200 / 272 2,000	212 / 288 2,000	219 / 298 2,200
Nominal speed		2,000		2,000	
Max. torque to ISO 14396		Nm at RPM	1,353 1,400	1,358 1,500	1,477 1,600
Displacement		9.0		9.0	
Bore / Stroke		mm 118.4 / 136		mm 118.4 / 136	
Available certifications		ECE R96 E		ECE R96 E	
Emission control		China Nonroad Stage 4, According to "HJ 1014-2020" Stage V, According to regulation (EU) 2016/1628		China Nonroad Stage 4, According to "HJ 1014-2020" Stage V, According to regulation (EU) 2016/1628	
Emission control		SCR technology and closed diesel particle filter system		SCR technology and closed diesel particle filter system	
Air cleaner system		Dry air filter with main and safety element, pre-cleaner, service indicator			
Electrical system					
Operating voltage		V	24	24	24
Battery		Ah	180	180	180
Alternator		V/A	24 / 100	24 / 100	24 / 100
Starter		V/kW	24 / 7.8	24 / 7.8	24 / 7.8

The availability of the models depends on the emission regulations of the respective countries.

L 566 II

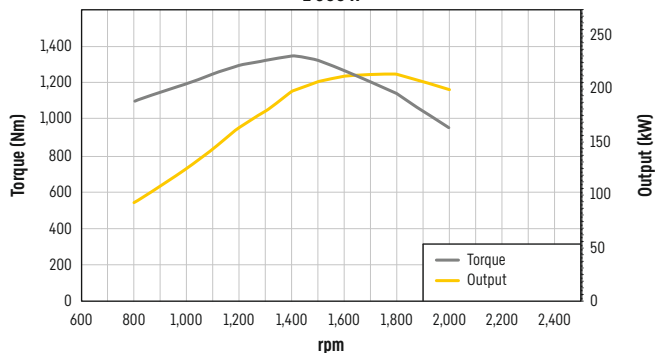

L 580 II

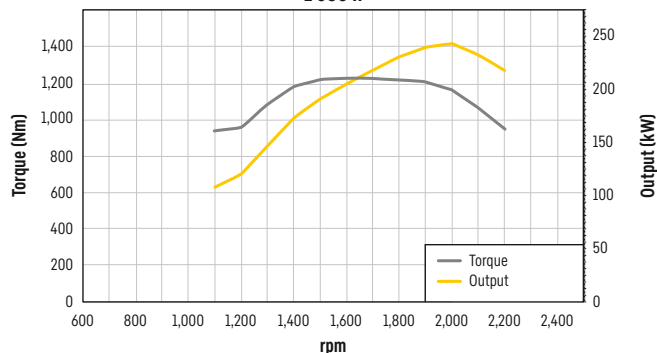

L 566 NR4 / Stage V

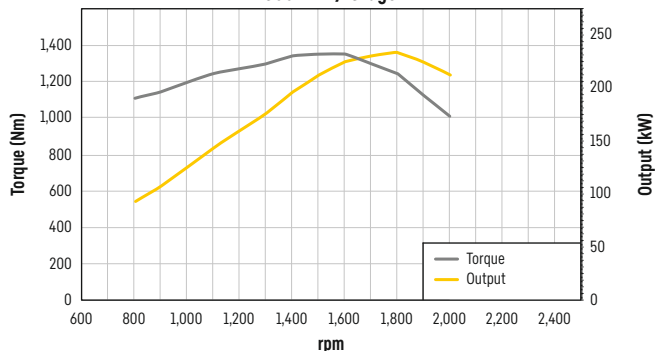

L 580 NR4 / Stage V

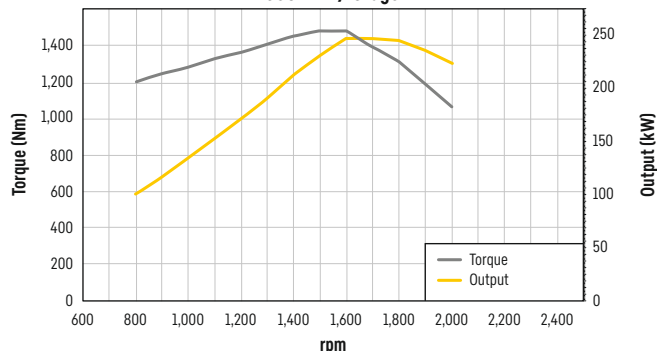

Driveline

Continuous hydrostatic driveline	
Design	Swash plate type variable flow pump and two variable axial piston motors in closed loop circuit and axle transfer case. Direction of travel is reversed by changing the flow-direction of the variable-displacement pump
Filtration	Suction return line filter for closed circuit
Control	By travel and inching pedal. The inching pedal makes it possible to control the tractive and thrust forces steplessly at full engine speed. The Liebherr control lever is used to control forward and reverse travel
Travel speed range	L 550:
	Speed range 1 _____ 0- 4 km/h
	Speed range A1-2 _____ 0-15 km/h
	Speed range A1-3 _____ 0-40 km/h* forward and reverse
	L 566 / L 580:
	Speed range 1 _____ 0-10 km/h
Speed range 2 and A2 _____ 0-20 km/h	
Speed range A3 _____ 0-40 km/h* forward and reverse	
	Speeds quoted apply with the tyres indicated as standard on loader model.

* Configuration, tyres and mounting tools can influence the maximum speed.

Axles

	L 550	L 566	L 580
Four-wheel drive			
Front axle	Fixed		
Rear axle	Centre pivot, with 13° oscillating angle to each side		
Height of obstacles which can be driven over	mm	460	490
		490	490
	with all four wheels remaining in contact with the ground		
Differentials	Automatic limited-slip differentials		
Reduction gear	Planetary final drive in wheel hubs		
Track width	2,000 mm with all types of tyres (L 550)		
	2,230 mm with all types of tyres (L 566, L 580)		

Steering

Design	"Load-sensing" swash plate type variable flow pump with pressure cut-off and flow control. Central pivot with two double-acting, damped steering cylinders
Angle of articulation	38° to each side
Emergency steering	Electro-hydraulic emergency steering system, optional

Attachment hydraulics

	L 550	L 566	L 580
Design	"Load-sensing" swash plate type variable flow pump with output and flow control, and pressure cut-off in the control block		
Cooling	Hydraulic oil cooling using thermostatically controlled fan and oil cooler		
Filtration	Return line filter in the hydraulic reservoir		
Control	Liebherr control lever with hydraulic servo control		
Lifting function	Lifting, neutral, lowering Float position controlled by Liebherr control lever with detent		
Tilt function	Tilt back, neutral, dump Automatic bucket return to dig as standard		
Max. flow	l/min.	234	290
Max. pressure		290	290
Z-bar linkage	bar	360	380
Industrial lift arm	bar	380	380

Attachment

	L 550	L 566	L 580
Geometry variants			
Optional	Powerfull Z-bar linkage with tilt cylinder and steel cross-tube Industrial lift arm with tilt cylinder, hydraulic quick coupler as standard		
Bearings	Sealed		
Cycle time at nominal load	ZK	IND	ZK
Lifting	s	5.4	5.4
Dumping	s	1.0	2.2
Lowering (empty)	s	2.9	2.9
		6.1	6.1
		2.0	1.4
		3.2	3.4
		6.2	6.2

Technical data

L 550 – L 566 – L 580



Operator's cab

Design	Elastic mounted, noise-proof cab ROPS roll over protection per EN ISO 3471 / EN 474-1 FOPS falling objects protection per EN ISO 3449 / EN 474-1, Cat. II Operator's door with 90° opening angle with rigid window, right side sliding side window, front windscreen made of laminated safety glass, green tinted as standard, side panels with single-pane safety glass ESG, green tinted, heated rear window ESG. Continuously adjustable steering column
Liebherr operator's seat	6 way adjustable, vibration-damped operator's seat "Standard" (mechanically sprung, adjustable to operator's weight), Liebherr control lever mounted into the operator's seat as standard
Cab heating and ventilation	2-level air control, cooling water heating, defroster and air conditioning via manual nozzle position or electronic valve control for head and front area, as well as electronic fresh / recirculated air control, electrically heated rear window, filter system with pre-filter, fresh air filter and recirculated air filter, easily replaced, air conditioning system with new improved cooling output as standard



Sound level

	L 550	L 566	L 580
Sound pressure level to ISO 6396			
L _{pA} (inside cab) dB(A)	73	73	75
Sound power level to 2000/14/EC			
L _{WA} (surround noise) dB(A)	105	106	106



Capacities

	L 550	L 566	L 580
Fuel tank l	300	450	450
DEF tank* l	20	20	20
Engine oil (inclusive filter change) l	20	34	34
Pump distribution gearbox l	-	3,5	3,5
Transmission l	4,1	12,5	12,5
Coolant l	34	55	55
Front axle l	35	42	58
Rear axle l	35	42	58
Hydraulic tank l	135	160	160
Hydraulic system, total l	240	280	280

*Not required for emission stage II.



Brakes

Wear-free service brake	Self-locking of the hydrostatic driveline (acting on all four wheels) and additional pump-accumulator brake system with wet multi-disc brakes (two separate brake circuits)
Parking brake	Electro-hydraulically actuated spring-loaded disc brake system on the transmission

The braking system meets the requirements of the ISO 3450.



Tyres

	L 550	L 566	L 580
Standard size	23.5R25 L3	26.5R25 L3	26.5R25 L3
Special tyres	By arrangement with the manufacturer		

Dimensions

Rehandling bucket (Z-bar linkage)

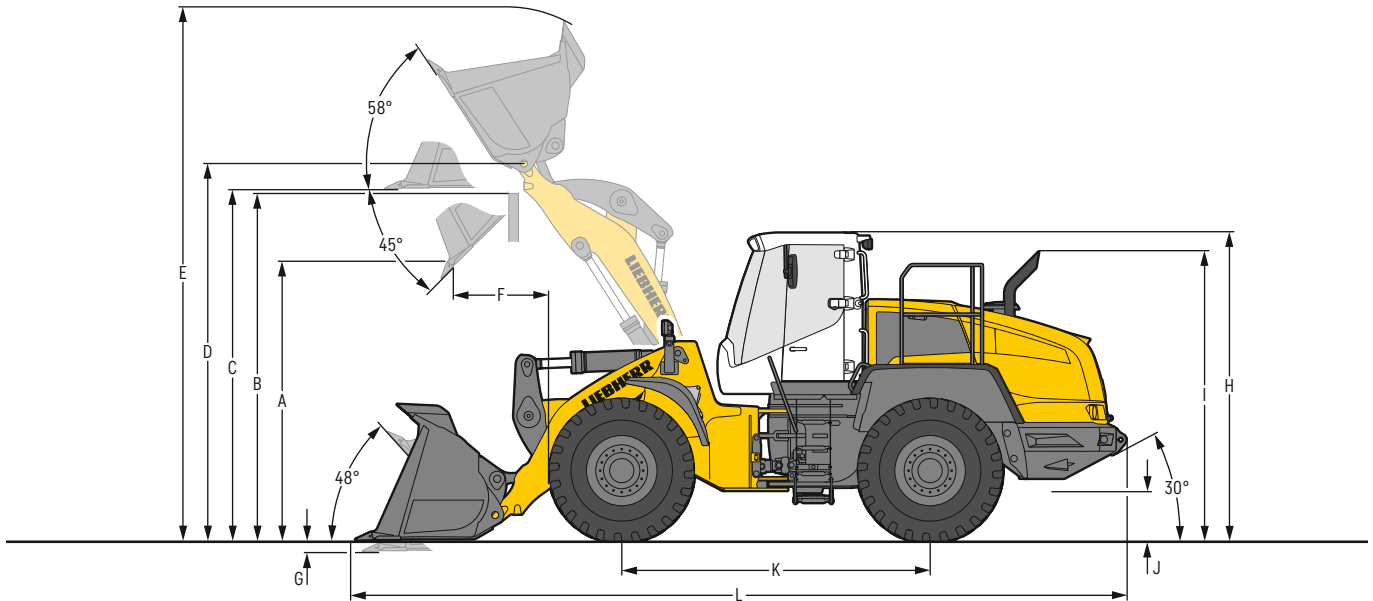

L 550-L 566-L 580

Rehandling bucket

	L 550			L 566				L 580				
	ZK	ZK	ZK-QC	ZK	ZK	ZK-QC	ZK	ZK	ZK	ZK-QC	ZK	
Geometry												
Cutting tools	T	T	T	T	T	BOCE	ROB	T	T	BOCE	ROB	
Lift arm length	mm	2,700	2,700	2,700	2,920	2,920	2,920	2,920	3,050	3,050	3,050	3,050
Bucket capacity according to ISO 7546**	m ³	3.4	3.7	3.1	4.2	4.7	3.5	3.7	5.2	5.7	4.5	4.5
Specific material density	t/m ³	1.8	1.6	1.8	1.8	1.6	1.8	1.8	1.8	1.6	1.8	1.8
Bucket width	mm	2,880	2,880	2,880	3,000	3,000	3,000	3,230	3,300	3,300	3,000	3,230
A Dumping height at max. lift height and 45° discharge	mm	3,020	2,970	2,930	3,090	3,050	3,085	3,130	3,300	3,220	3,160	3,320
B Dump-over height	mm	3,700	3,700	3,700	3,900	3,900	3,900	3,900	4,100	4,100	4,100	4,100
C Max. height of bucket bottom	mm	3,875	3,875	3,875	4,050	4,050	4,050	4,050	4,270	4,270	4,270	4,270
D Max. height of bucket pivot point	mm	4,150	4,150	4,150	4,360	4,360	4,360	4,360	4,580	4,580	4,580	4,360
E Max. operating height	mm	5,785	5,855	5,830	6,045	6,150	6,200	6,070	6,380	6,500	6,590	6,170
F Reach at max. lift height and 45° discharge	mm	1,025	1,075	1,140	1,305	1,375	1,360	1,270	1,330	1,285	1,460	1,350
G Digging depth	mm	80	80	110	100	100	100	100	100	100	100	100
H Height above operator's cab	mm	3,360	3,360	3,360	3,590	3,590	3,590	3,590	3,590	3,590	3,590	3,590
I Height above exhaust	mm	3,015	3,015	3,015	3,315	3,315	3,315	3,315	3,315	3,315	3,315	3,315
J Ground clearance	mm	490	490	490	535	535	535	535	465	465	465	465
K Wheelbase	mm	3,410	3,410	3,410	3,820	3,820	3,820	3,820	3,970	3,970	3,970	3,970
L Overall length	mm	8,525	8,595	8,665	9,200	9,300	9,240	9,150	9,545	9,625	9,720	9,575
Turning circle radius over tyres	mm	6,300	6,300	6,300	7,110	7,110	7,110	7,110	7,300	7,300	7,300	7,300
Turning circle radius over outside bucket edge	mm	6,910	6,930	6,950	7,690	7,720	7,700	7,780	8,075	8,095	7,980	8,030
Width over tyres	mm	2,650	2,650	2,650	2,960	2,960	2,960	2,960	2,960	2,960	2,960	2,960
Breakout force (SAE)	kN	165	155	145	190	180	190	185	220	205	205	215
Tipping load, straight*	kg	14,120	14,000	13,240	18,150	17,900	17,450	18,700	21,650	21,500	20,800	22,000
Tipping load, fully articulated*	kg	12,430	12,300	11,100	15,900	15,650	15,100	16,100	18,950	18,800	18,100	19,150
Operating weight*	kg	17,750	17,810	18,180	23,450	23,550	24,330	25,250	26,950	27,100	27,730	28,580
Tyre size		23.5R25 L3			26.5R25 L3				26.5R25 L5			

* The figures shown here are valid with tyres above (optional tyres will change the vertical dimensions), includes all lubricants, a full fuel tank, the ROPS/FOPS cab and the operator. Different tyres and optional equipment will change the operating weight and tipping load. (Tipping load, fully articulated to ISO 14397-1)

** Actual bucket capacity may be approx. 10% larger than the calculation according to ISO 7546 standard. The degree to which the bucket can be filled depends on the material - see page 36.

ZK = Z-bar linkage

ZK-QC= Z-bar linkage incl. quick coupler

T = Welded-on tooth holder with add-on teeth

BOCE = Bolt-on cutting edge

ROB = Rock bucket with delta cutting edge, welded-on tooth holder with add-on teeth and bolted intermediate sections

Dimensions

Rehandling bucket (Z-bar linkage high lift)

L 550-L 566-L 580

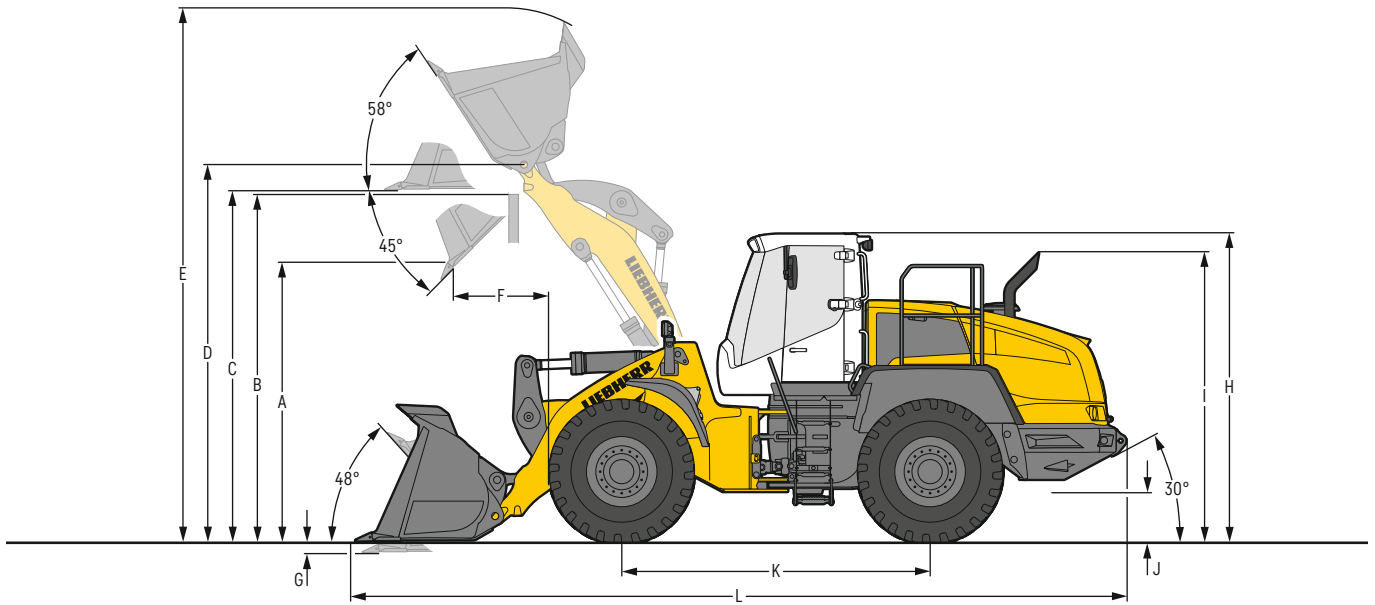

Rehandling bucket

	L 550	L 566	L 580
Geometry	ZK	ZK	ZK
Cutting tools	T	T	T
Lift arm length	mm 3,100	3,250	3,250
Bucket capacity according to ISO 7546**	m ³ 3.1	4.2	5.2
Specific material density	t/m ³ 1.6	1.6	1.6
Bucket width	mm 2,880	3,000	3,300
A Dumping height at max. lift height and 45° discharge	mm 3,670	3,650	3,490
B Dump-over height	mm 4,200	4,300	4,300
C Max. height of bucket bottom	mm 4,430	4,470	4,470
D Max. height of bucket pivot point	mm 4,700	4,780	4,780
E Max. operating height	mm 6,255	6,555	6,740
F Reach at max. lift height and 45° discharge	mm 890	1,200	1,265
G Digging depth	mm 95	140	140
H Height above operator's cab	mm 3,360	3,590	3,590
I Height above exhaust	mm 3,015	3,315	3,315
J Ground clearance	mm 490	535	465
K Wheelbase	mm 3,410	3,820	3,970
L Overall length	mm 8,960	9,615	9,795
Turning circle radius over tyres	mm 6,300	7,110	7,300
Turning circle radius over outside bucket edge	mm 7,110	7,850	8,175
Width over tyres	mm 2,650	2,960	2,960
Breakout force (SAE)	kN 165	200	225
Tipping load, straight *	kg 11,600	15,850	20,030
Tipping load, fully articulated *	kg 10,150	13,700	17,450
Operating weight *	kg 17,990	24,000	27,100
Tyre sizes	23.5R25 L3	26.5R25 L3	26.5R25 L3

* The figures shown here are valid with tyres above (optional tyres will change the vertical dimensions), includes all lubricants, a full fuel tank, the ROPS/FOPS cab and the operator. Different tyres and optional equipment will change the operating weight and tipping load. (Tipping load, fully articulated to ISO 14397-1)

** Actual bucket capacity may be approx. 10% larger than the calculation according to ISO 7546 standard. The degree to which the bucket can be filled depends on the material - see page 36.

ZK = Z-bar linkage

T = Welded-on tooth holder with add-on teeth

Attachment

Light material bucket (Z-bar linkage)

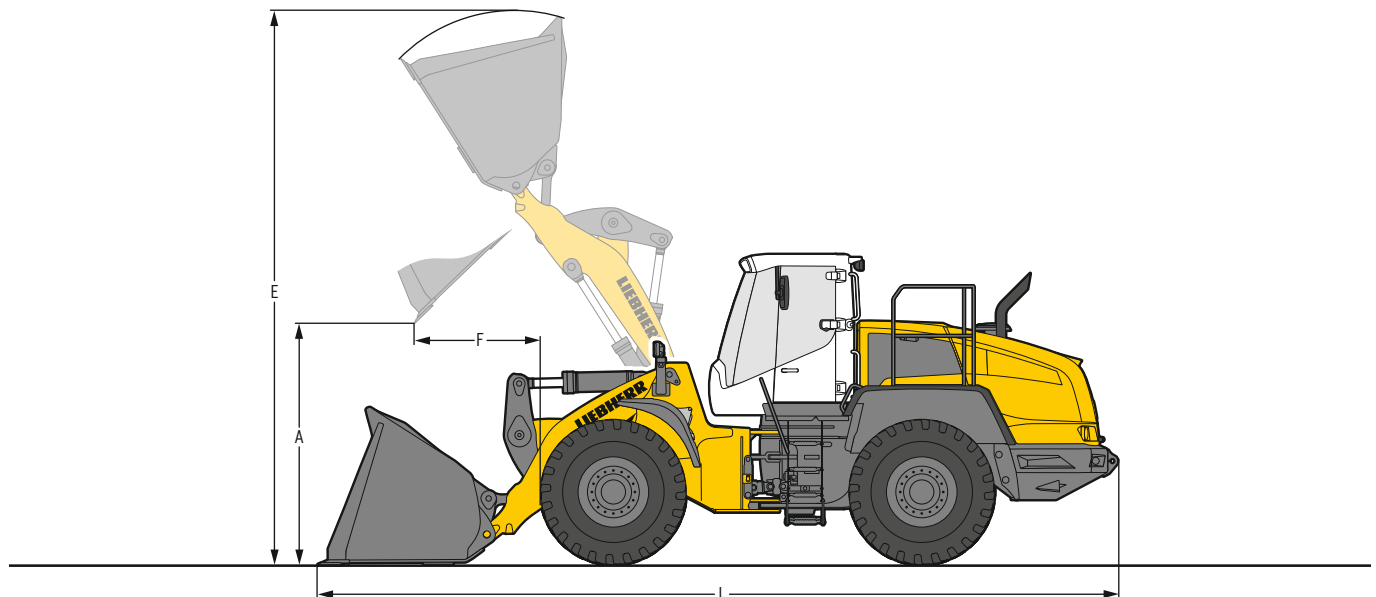

L 550-L 566-L 580



Light material bucket

	L 550		L 566		L 580		
	ZK	ZK	ZK	ZK	ZK	ZK	
Geometry							
Cutting tools	BOCE		BOCE		BOCE		
Bucket capacity	m ³	5.5	7.0	5.7	7.0	8.5	
Specific material density	t/m ³	1.0	0.75	1.2	1.0	1.0	
Bucket width	mm	2,950	3,200	3,300	3,200	3,500	
A Dumping height at max. lift height	mm	2,715	2,680	2,990	2,920	3,030	2,960
E Max. operating height	mm	5,970	6,020	6,280	6,330	6,610	6,650
F Reach at maximum lift height	mm	1,385	1,425	1,445	1,330	1,340	1,410
L Overall length	mm	8,775	8,830	9,380	9,440	9,580	9,690
Tipping load, straight*	kg	13,050	12,600	17,250	17,500	21,400	20,750
Tipping load, fully articulated*	kg	11,420	11,000	14,900	15,100	18,500	18,050
Operating weight*	kg	18,320	18,600	24,280	24,150	27,400	27,390
Tyre size		23.5R25 L3		26.5R25 L3		26.5R25 L3	

* The figures shown here are valid with tyres above (optional tyres will change the vertical dimensions), includes all lubricants, a full fuel tank, the ROPS/FOPS cab and the operator. Different tyres and optional equipment will change the operating weight and tipping load. (Tipping load, fully articulated according to ISO 14397-1)

ZK = Z-bar linkage

BOCE = Bolt-on cutting edge

Dimensions

Light material bucket (industrial lift arm)

L 550-L 566-L 580

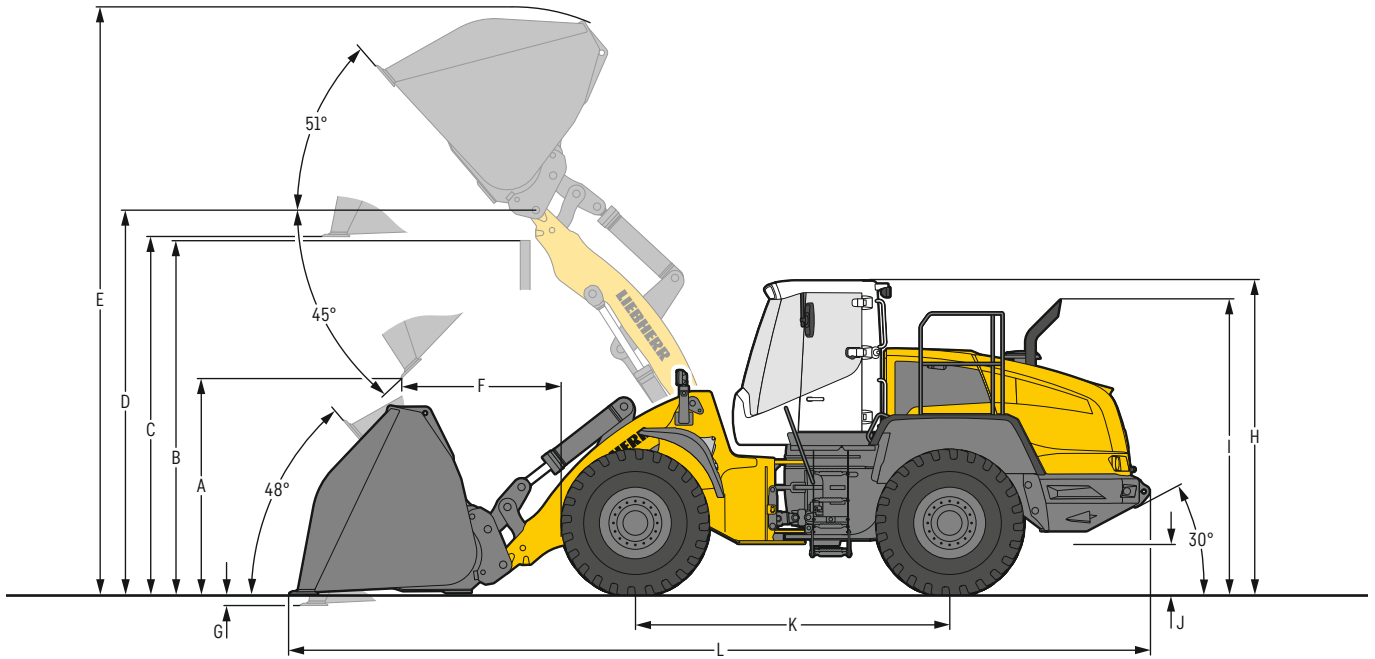

Light material bucket

	L 550	L 566	L 580
Geometry	IND-QC	IND-QC	IND-QC
Cutting tools	BOCE	BOCE	BOCE
Lift arm length	mm 2,700	mm 2,900	mm 2,900
Bucket capacity according to ISO 7546**	m ³ 9.5	m ³ 12.0	m ³ 14.0
Specific material density	t/m ³ 0.5	0.45	0.45
Bucket width	mm 3,400	mm 3,700	mm 4,000
A Dumping height at max. lift height and 45° discharge	mm 2,320	mm 2,885	mm 2,480
B Dump-over height	mm 3,700	mm 3,900	mm 3,900
C Max. height of bucket bottom	mm 3,865	mm 4,145	mm 4,145
D Max. height of bucket pivot point	mm 4,145	mm 4,490	mm 4,490
E Max. operating height	mm 6,270	mm 6,470	mm 6,800
F Reach at max. lift height and 45° discharge	mm 1,740	mm 1,485	mm 1,950
G Digging depth	mm 100	mm 100	mm 100
H Height above operator's cab	mm 3,360	mm 3,590	mm 3,590
I Height above exhaust	mm 3,015	mm 3,315	mm 3,315
J Ground clearance	mm 490	mm 535	mm 465
K Wheelbase	mm 3,410	mm 3,890	mm 3,970
L Overall length	mm 9,220	mm 10,185	mm 10,300
Turning circle radius over tyres	mm 6,300	mm 7,200	mm 7,300
Turning circle radius over outside bucket edge	mm 7,430	mm 8,275	mm 8,585
Width over tyres	mm 2,650	mm 2,960	mm 2,960
Breakout force (SAE)	kN 85	110	125
Tipping load, straight *	kg 11,890	15,350	18,500
Tipping load, fully articulated *	kg 10,300	13,150	15,900
Operating weight *	kg 19,120	25,950	28,900
Tyre sizes	23.5R25 L3	26.5R25 L3	26.5R25 L3

* The figures shown here are valid with tyres above (optional tyres will change the vertical dimensions), includes all lubricants, a full fuel tank, the ROPS/FOPS cab and the operator. Different tyres and optional equipment will change the operating weight and tipping load. (Tipping load, fully articulated to ISO 14397-1)

** Actual bucket capacity may be approx. 10% larger than the calculation according to ISO 7546 standard. The degree to which the bucket can be filled depends on the material - see page 36.

IND-QC = Industrial lift arm with parallel guidance incl. quick coupler
BOCE = Bolt-on cutting edge

Attachment

High dump bucket (industrial lift arm)

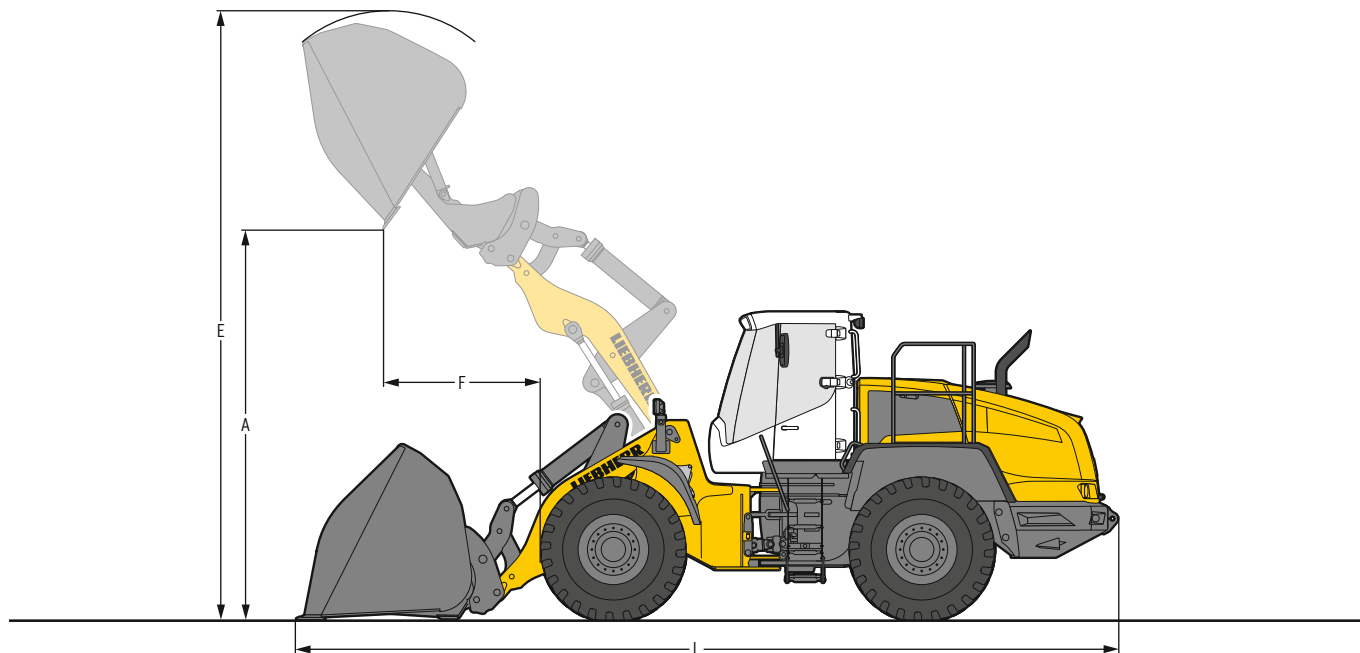

L 550-L 566-L 580



High-dump bucket

		L 550		L 566	
Geometry		IND-QC	IND-QC	IND-QC	IND-QC
Cutting tools		BOCE	BOCE	BOCE	BOCE
Bucket capacity	m ³	4,5	5,5	9,0	11,0
Specific material density	t/m ³	1,0	0,8	0,5	0,45
Bucket width	mm	2,700	2,700	3,400	3,700
A Dumping height at max. lift height	mm	4,645	4,420	4,335	4,840
E Max. operating height	mm	6,865	7,110	7,090	7,490
F Reach at maximum lift height	mm	1,685	1,840	1,720	2,140
L Overall length	mm	8,950	9,250	9,240	10,185
Tipping load, straight*	kg	12,000	10,750	11,500	15,100
Tipping load, fully articulated*	kg	10,400	9,300	9,900	12,900
Operating weight*	kg	18,900	19,400	19,550	26,450
Tyre size		23.5R25 L3	23.5R25 L4	23.5R25 L5	26.5R25 L3

* The figures shown here are valid with tyres above (optional tyres will change the vertical dimensions), includes all lubricants, a full fuel tank, the ROPS / FOPS cab and the operator. Different tyres and optional equipment will change the operating weight and tipping load. (Tipping load, fully articulated according to ISO 14397-1)

IND-QC = Industrial lift arm with parallel guidance incl. quick coupler
BOCE = Bolt-on cutting edge

Attachment

Fork carrier and fork (industrial lift arm)

L 550-L 566-L 580

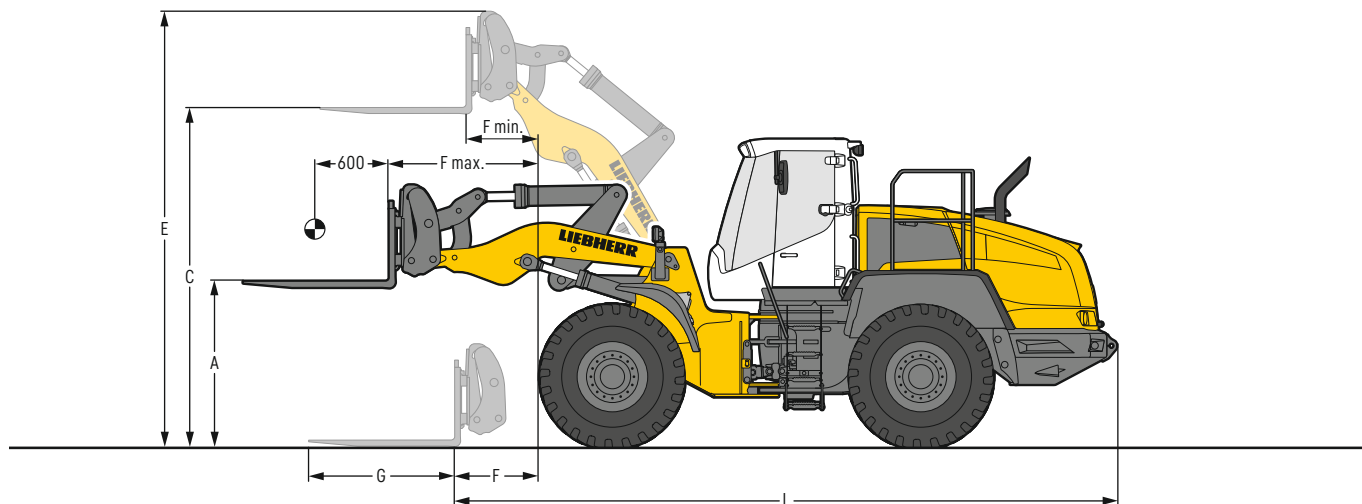

FEM IV fork carrier and fork

	L 550	L 566	L 580
Geometry	IND-QC	IND-QC	IND-QC
A Lifting height at max. reach	1,805	2,075	2,075
C Max. lifting height	3,905	4,220	4,220
E Max. operating height	4,895	5,200	5,200
F Reach at loading position	1,080	1,145	1,025
F max. Max. reach	1,710	1,925	1,805
F min. Reach at max. lifting height	715	980	860
G Fork length	1,500	1,800	1,800
L Length - basic machine	7,450	8,280	8,280
Tipping load, straight *	10,840	13,500	16,300
Tipping load, fully articulated *	9,560	11,900	14,400
Recommended payload for uneven ground = 60% of tipping load, articulated ¹⁾	5,740	7,140	8,640
Recommended payload for smooth surfaces = 80% of tipping load, articulated ¹⁾	7,650	9,520	10,000
Operating weight*	17,560	23,650	26,350
Tyre size	23.5R25 L3	26.5R25 L3	26.5R25 L3

* The figures shown here are valid with tyres above (optional tyres will change the vertical dimensions), includes all lubricants, a full fuel tank, the ROPS/FOPS cab and the operator. Different tyres and optional equipment will change the operating weight and tipping load. (Tipping load, fully articulated according to ISO 14397-1)

¹⁾ According to EN 474-3

IND-QC = Industrial lift arm with parallel guidance incl. quick coupler

Attachment

Log grapple (industrial lift arm)

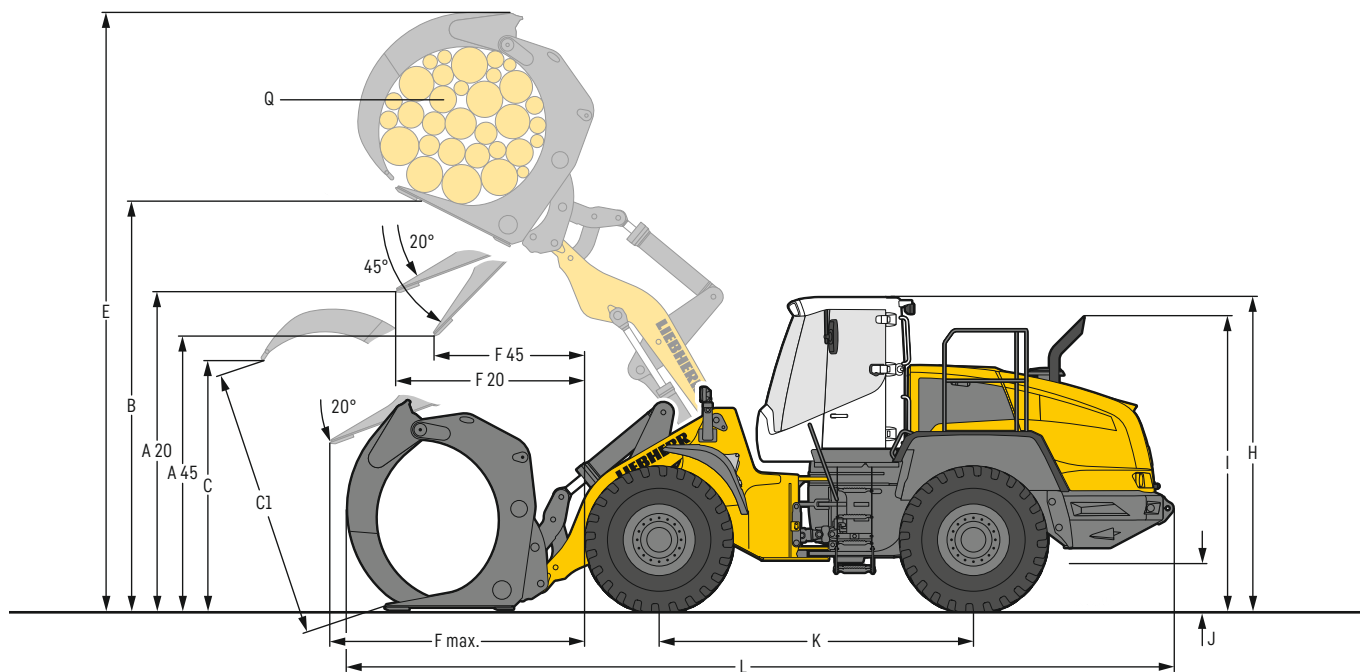

L 550 - L 566 - L 580

Log grapple

		L 550		L 566	L 580
Geometry		IND-QC	IND-QC	IND-QC	IND-QC
A20	Discharge height at 20°	mm	3,420	3,350	3,570
A45	Discharge height at 45°	mm	2,940	2,770	2,930
B	Manipulation height	mm	4,550	4,655	5,125
C	Max. grapple opening in loading position	mm	2,395	2,740	2,650
C1	Max. grapple opening	mm	2,590	2,990	3,050
E	Max. height	mm	6,230	6,650	7,400
F20	Reach at max. lifting height at 20° discharge	mm	1,590	1,810	2,165
F45	Reach at max. lifting height at 45° discharge	mm	1,160	1,330	1,620
F max.	Max. reach	mm	2,590	2,810	3,110
H	Height above operator's cab	mm	3,360	3,360	3,590
I	Height above exhaust	mm	3,015	3,015	3,315
J	Ground clearance	mm	490	490	535
K	Wheelbase	mm	3,410	3,410	3,890
L	Overall length	mm	8,705	8,985	9,960
	Width over tyres	mm	2,650	2,650	2,970
Q	Grapple diameter	m ²	1.8	2.4	3.1
	Grapple width	mm	1,600	1,600	1,800
	Payload*	kg	6,450	6,300	8,200
	Operating weight*	kg	18,770	18,920	26,200
	Tyre size		23.5R25 L3	26.5R25 L3	26.5R25 L3

* The figures shown here are valid with tyres above (optional tyres will change the vertical dimensions), includes all lubricants, a full fuel tank, the ROPS / FOPS cab and the operator. Different tyres and optional equipment will change the operating weight and payload.

IND-QC = Industrial lift arm with parallel guidance incl. quick coupler

Bucket selection

L 550-L 566-L 580

L 550

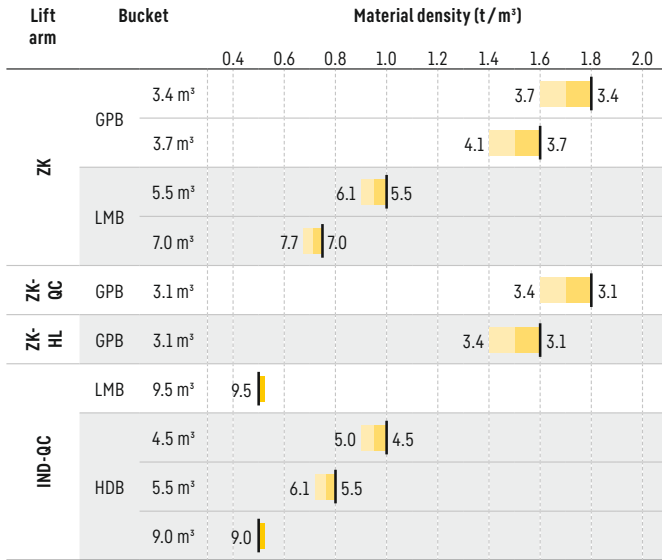

L 566

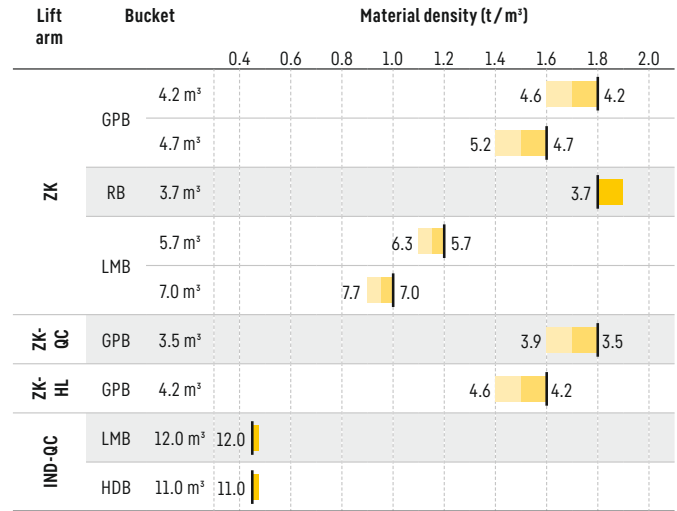

L 580

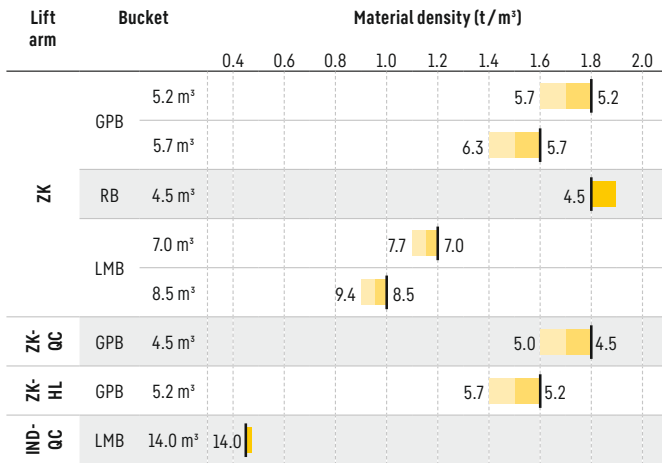

Bucket filling factor

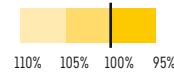

Lift arm

- ZK Z-bar linkage, standard lift arm length
- ZK-QC Z-bar linkage with quick coupler, standard lift arm length
- ZK-HL Z-bar linkage, High Lift
- IND-QC Industrial lift arm with quick coupler, standard lift arm length

Bucket

- GPB General purpose bucket (Rehandling bucket)
- LMB Light material bucket
- HDB High-dump bucket
- RB Rock bucket

Bulk material densities and bucket filling factors

Material	State	t/m³	%	Material	State	t/m³	%	Material	State	t/m³	%
Gravel	moist	1.9	105	Earth	dry	1.3	115	Glass waste	Wastebroken	1.4	100
	dry	1.6	105		wet excavated	1.6	110		solid	1.0	100
	crushed stone	1.5	100	Topsoil		1.1	110	Compost	dry	0.8	105
Sand	dry	1.5	105	Basalt		1.95	100		wet	1.0	110
	wet	1.9	110	Granite		1.8	95	Wood chips / Saw dust		0.5	110
Gravel and Sand	dry	1.7	105	Sandstone		1.6	100		Paper	shredded / loose	0.6
	wet	2.0	100	Slate		1.75	100	recovered paper / cardboard		1.0	110
Sand / Clay		1.6	110	Bauxite		1.4	100	Coal	heavy material density	1.2	110
Clay	natural	1.6	110	Limestone		1.6	100		light material density	0.9	110
	dry	1.4	110	Gypsum	broken	1.8	100	Waste	domestic waste	0.5	100
Clay / Gravel	dry	1.4	110	Coke		0.5	110		bulky waste	1.0	100
	wet	1.6	100	Slag	broken	1.8	100				

Tipping load

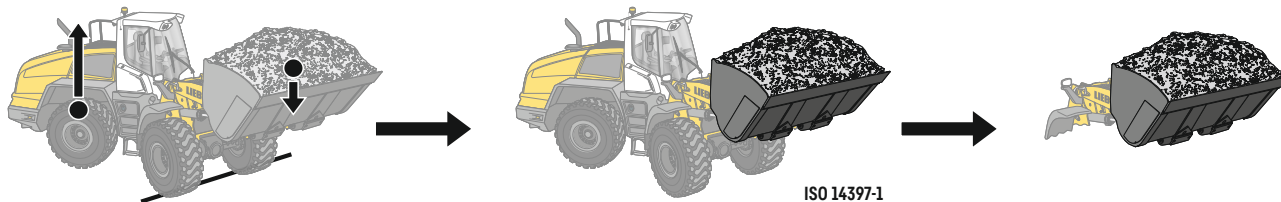

What is tipping load?

Load at centre of gravity of working equipment, so that the wheel loader just begins to tip over the front axle. This is the most unfavourable static-load position for the wheel loader. Lifting arms horizontal, wheel loader fully articulated at centre pivot.

Pay load.

The pay load must not exceed 50% of the tipping load when articulated.

This is equivalent to a static stability-margin factor of 2.0.

Bucket capacity.

The bucket volume is determined from the pay load.

$$\text{Pay load} = \frac{\text{Tipping load, articulated}}{2}$$

$$\text{Bucket capacity} = \frac{\text{Pay load (t)}}{\text{Specific bulk weight of material (t/m}^3\text{)}}$$

Wheel loader



		L 524	L 538	L 550	L 566	L 580
Tipping load	kg	7,500	9,500	12,430	15,900	18,950
Bucket capacity	m ³	2.0	2.5	3.4	4.2	5.2
Operating weight	kg	10,400	12,800	17,750	23,450	26,950
Engine output Stage II	kW / HP	-	-	168 / 228	200 / 272	219 / 298
Engine output Stage IIIA (compliant)	kW / HP	86 / 117	104 / 141	-	-	-
Engine output BS4 / Stage V	kW / HP	-	-	168 / 228	-	-
Engine output NR China IV / Stage V	kW / HP	-	-	161 / 219	212 / 288	224 / 305

02.22

Environmental protection can help you earn money!

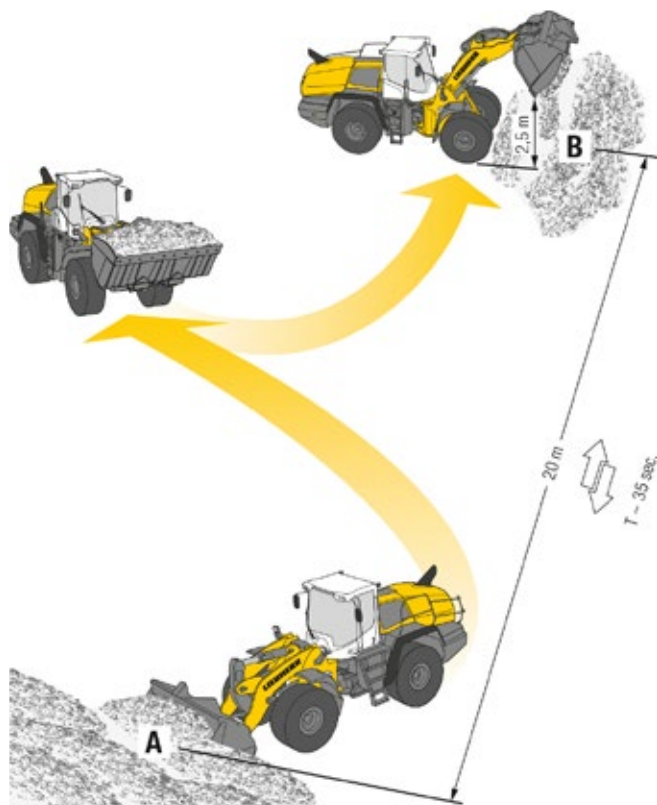

The Liebherr Standard Consumption Test – easy to reproduce and practical.

The Liebherr Standard Consumption Test determines the number of loading cycles that can be carried out with 5 litres of diesel. The material is taken from pile A and carried over a distance of 20 metres to point B. The time needed for each working cycle should be 35 seconds. Discharge at point B should take place from a height of 2.5 m. The working cycles continue until the 5 litres of diesel in the external measuring tank have been used up. The loader's fuel consumption per operating hour is calculated as follows:

$$\frac{400}{\text{Number of loading cycles}} = \text{Consumption per hour}$$

Values for the Liebherr Wheel Loaders

	Numbers of working cycles	Litres / 100 tons	Litres / hour
L 524: 2.0 m ³	n = 47	2.9	8.5
L 538: 2.5 m ³	n = 39	2.9	10.3
L 550: 3.4 m ³	n = 30	2.9	13.5
L 566: 4.2 m ³	n = 23	3.0	17.3
L 580: 5.2 m ³	n = 21	2.6	19.1

Equipment



Basic wheel loader

	L 550	L 566	L 580
Crash protection, rear	+	+	+
Ramming guard	-	+	+
Engine shut-down (5 min < 1,000 rpm)	+	+	+
Additional speed limit - variable & fixed acceleration	+	+	+
Automatic central lubrication system	+	+	+
Battery main switch (lockable)	●	+	+
Ride control	+	+	+
Parking brake	●	●	●
Fluff trap for radiator	+	+	+
Pre-heat system for cold starting	+	+	+
Rear license panel light	+	+	+
Combined inching-braking system	●	●	●
Mudguard in plastic design	●	●	●
Fuel tank in plastic design	●	●	●
Fuel tank in steel design (with guard)	+	+	+
Fuel pre-filter	●	●	●
Fuel pre-filter with pre-heating	+	+	+
Large-mesh radiator	+	+	+
Cooling water pre-heating 230 V	+	+	+
Multi-disc limited slip differentials in both axles	●	●	●
Light carrier in plastic design	+	-	-
Light carrier in steel design (with guard for LED)	+	+	+
Reversible fan drive	+	+	+
Headlights LED (double design on engine hood)	-	+	+
Auxiliary heater (Additional heating with engine preheating)	+	+	+
Dust protection for alternator	+	+	+
Lockable doors and engine hood	●	●	●
Additional handrails (left & right)	-	+	+
Carrying case with tool kit	●	●	●
Chassis protection rear / front	+	+	+
Chock	+	+	+
Air pre-cleaner oil bath filter	+	+	+
Air pre-cleaner standard	●	●	●
Air pre-cleaner TOP SPIN	+	+	+
Liebherr weighing system with "Truck Payload Assist" (cannot be calibrated)	+	+	+
Towing hitch	●	●	●



Equipment

	L 550	L 566	L 580
Working hydraulics lockout	●	●	●
Fork carrier and pallet forks	+	+	+
High-dump bucket	+	+	+
Log grapple	+	+	+
Automatic lift arm position and lowering programmable	+	+	+
High Lift arms	+	+	+
Industrial lift arm	+	+	+
Lift arm Z-bar linkage	●	●	●
Hydraulic quick coupler	+	+	+
Tilt cylinder protection	+	+	+
Loading buckets incl. a range of cutting tools	+	+	+
Light material bucket	+	+	+
Option package "comfort operation":			
- Automatic lift kick-out			
- Automatic bucket return programmable			
- Reduction valve for bucket discharge speed	+	+	+
Automatic lowering with bucket tipped inwards	+	+	+
Bucket tilt assist	+	+	+
Pipe break protection	+	+	+
Lifting frame cylinder stroke limit damping	+	+	+
Float position	●	●	●
1st additional hydraulic function	+	+	+
1st additional hydraulic function for continuous mode	+	+	+
1st and 2nd additional hydraulic function	+	+	+

Equipment



Operator's cab

	L 550	L 566	L 580
Armrest left	+	+	+
Exterior mirror, electrical adjustable with heating	+	+	+
Exterior mirror, tilttable	•	•	•
Operating hour meter (integrated in display unit)	•	•	•
Storage box	•	•	•
Operator seat "Comfort" – pneumatic suspension with seat heating	+	+	+
Operator seat "Standard" – mechanically sprung	•	•	•
Heater	•	•	•
Horn operation with right button	+	+	+
Floor mat	•	•	•
Clothes hook	•	•	•
Air conditioning system	•	•	•
Headrest	+	+	+
Steering column adjustable	•	•	•
Liebherr control lever – adjustable	•	•	•
Liebherr control lever with mini-joystick	+	+	+
Emergency steering pump	+	+	+
Radio Liebherr "Standard" (USB / AUX)	•	•	•
Amber beacon swivelling, LED	+	+	+
Activation of amber beacon during back-up	+	+	+
Soundproof ROPS / FOPS cab	•	•	•
Wipe and wash system	•	•	•
Headlights rear, single design, halogen	•	•	•
Headlights rear, single design, LED	+	+	+
Headlights rear, double design, halogen	+	+	+
Headlights rear, double design, LED	+	+	+
Headlights rear, triple design, LED	+	+	+
Headlights front, double design, halogen	•	•	•
Headlights front, double design, LED	+	+	+
Sliding window right	•	•	•
Windscreen guard	+	+	+
Sunblind rear / front	+	+	+
Power socket 12V	•	•	•
Preparation for LiDAT	+	+	+
Cigarette lighter	•	•	•
9" touch screen display	•	•	•



Safety

	L 550	L 566	L 580
CE safety package	+	+	+
Country-specific versions	+	+	+
Emergency steering system	+	+	+
Back-up alarm acoustic	•	•	•
Rear space monitoring with camera	+	+	+

- = Standard
- + = Option
- = not available

The Liebherr Group



Global and independent: more than 70 years of success

Liebherr was founded in 1949 when, with the development of the world's first mobile tower crane, Hans Liebherr laid the foundations for a family business now employing nearly 51,000 people and comprising over 140 companies across every continent.

The parent company is Liebherr-International AG in Bulle, Switzerland, whose associates are exclusively members of the Liebherr family.

Leaders and pioneers

Liebherr is a pioneer and its forward-looking approach has seen it make important contributions to technology history over a wide variety of industries. Employees throughout the world continue to share the courage of the founder, sharing a passion to produce innovative products and a determination to provide world-leading equipment and machinery.

Diversified portfolio

The company is one of the world's biggest construction equipment manufacturers and provides high-quality, user-oriented products and services to sectors including: earthmoving, material handling, deep foundations, mining, mobile and crawler cranes, tower cranes, concrete production and distribution, maritime cranes, aerospace and transportation, gear technology and automation, refrigeration and freezing, components and hotels.

Customised care

Liebherr solutions are characterised by precision, implementation and longevity. The company is committed to technological excellence and to providing customers with solutions that match their needs exactly. That customer focus does not end with delivery of a product but continues through a comprehensive range of back-up and support services.

www.liebherr.com

Liebherr-Werk Bischofshofen GmbH

Postfach 49 · 5500 Bischofshofen, Austria · Phone +43 50809 1-0 · Fax +43 50809 11385
info.lbh@liebherr.com · www.liebherr.com · www.facebook.com/LiebherrConstruction