

Assembly instructions

EN

STE 7

ST 8/SGT 8

ST 9/SGT 9

ST 10/SGT 10

ST 11/SGT 11

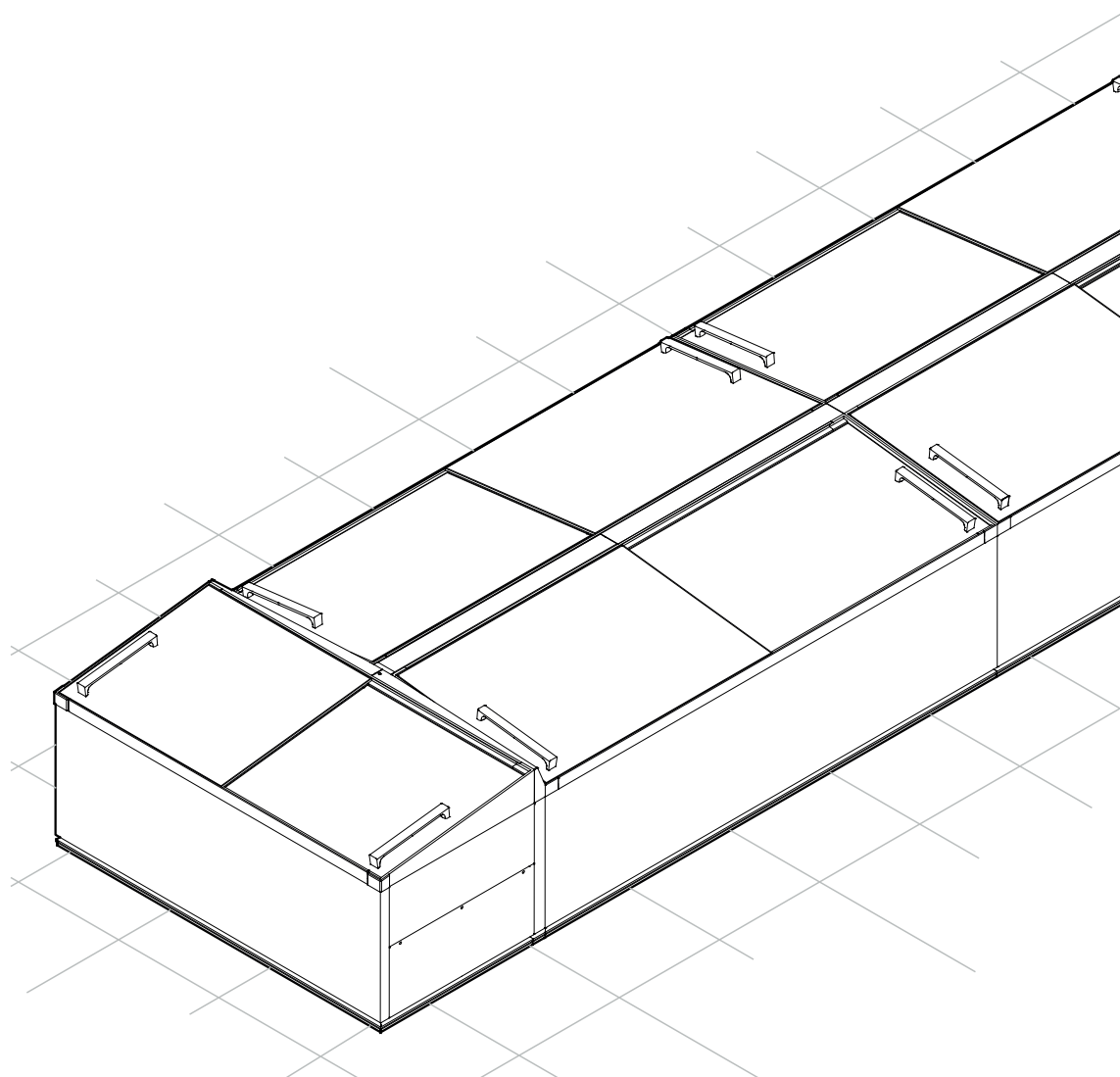

7084 814-01

LIEBHERR

Content

Safety instructions and warnings	3	Fitting various accessories.....	30
Appliance dimensions.....	3	Fitting product plate holders.....	30
Appliance types	3	Product plate holders for longitudinal appliances, rear..	30
Cable lengths.....	3	Product plate holders, front.....	31
Requirements for assembly	4	Corner protection	31
Requirements for the place of installation.....	4	Fitting the collision guard.....	32
Requirements for the electrical connection	4	Block completion with end-of-aisle appliance	32
Requirements for a remote data transmission connection..	5	Block completion with cover plate.....	32
Bus connection	5	Collision guard for longitudinal chests.....	32
Addressing.....	5	Technical data	
Bedienung (nur LSC-Variante)	5	Appliance type: SMALL	33
Scope of delivery	6	Technical data	
Standard (per appliance).....	6	Appliance type: MEDIUM.....	33
Accessories (depending on configuration)	6	Technical data	
Accessories (optional).....	6	Appliance type: SMALL	34
Positioning aid: spacer	6	Technical data	
Positioning rail.....	6	Appliance type: MEDIUM.....	34
Sealing strip	6		
End-of-aisle appliance connection kit	6		
Block completion with cover plate (without end-of-aisle chest).....	6		
Protection strip for longitudinal appliances.....	6		
Protection strip without end-of-aisle chest	6		
Protection strip with end-of-aisle chest	6		
Cover for block configuration	6		
Cover for wall mounting	6		
Product plate holder.....	6		
Corner protection	6		
Plug set for alarm output	6		
End-of-aisle appliance collision guard	6		
Collision guard for block completion with cover plate.....	6		
Collision guard for longitudinal chests.....	6		
Transport and unpacking	7		
Moving the appliances to the place of installation	7		
Possible configurations	7		
Installing an individual appliance.....	7		
Installing appliances in a row.....	8		
Installing the appliances in a block or in island form.....	8		
Installation and connection	10		
Affixing shaped foam tape.....	10		
Fitting the sealing strip	10		
Fitting the cables	11		
Fitting the service interface extension.....	13		
External alarm (floating alarm output)	14		
Connecting appliances.....	15		
End-of-aisle appliance connection kit.....	15		
Block completion with cover plate (without end-of-aisle chest)	18		
Fitting the protection strips	20		
Individual appliance	20		
Row configuration	22		
Block configuration	23		
Cover for block configuration.....	25		
Cover for wall mounting.....	27		
Assigning addresses to the appliances	29		
Commissioning the appliances	30		
Checks	30		

Safety instructions and warnings

- If there is obvious transport damage on the appliance after it has been unpacked, contact the supplier. Do not switch on the appliance.
- Do not allow naked flames or ignition sources to enter the appliance. When transporting and cleaning the appliance, ensure that the refrigerant circuit is not damaged. In the event of damage, make sure that there are no ignition sources nearby and keep the room well ventilated.
- Do not place objects on the appliance and do not place heavy loads on the sliding glass lids. The lids could be damaged.

Appliance dimensions

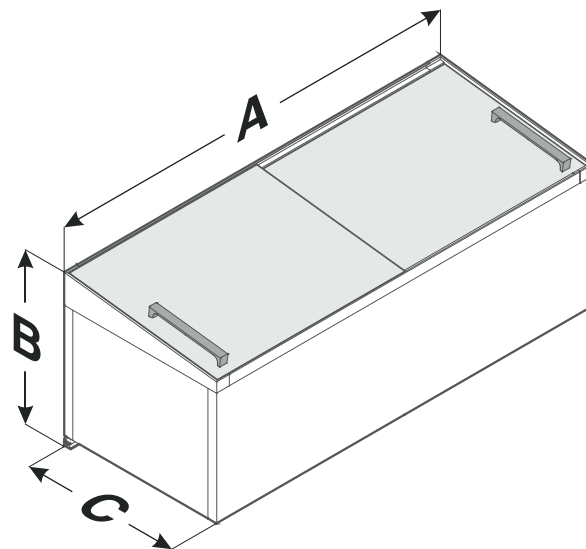

Appliance types

	A [mm]	B [mm]	C [mm]
SGTEs 772	1800	840	850
STEs 772/752	1800	840	850
STEm 872/852	1800	890	850
SGTEm 872	1800	890	850
SGTs-STs 872/852	2100	840	850
SGTm-STm 972/952	2100	890	850
SGTs-STs 1072/1052	2500	840	850
SGTm-STm 1172/1152	2500	890	850

Cable lengths

Free cable lengths from strain relief device outlet.

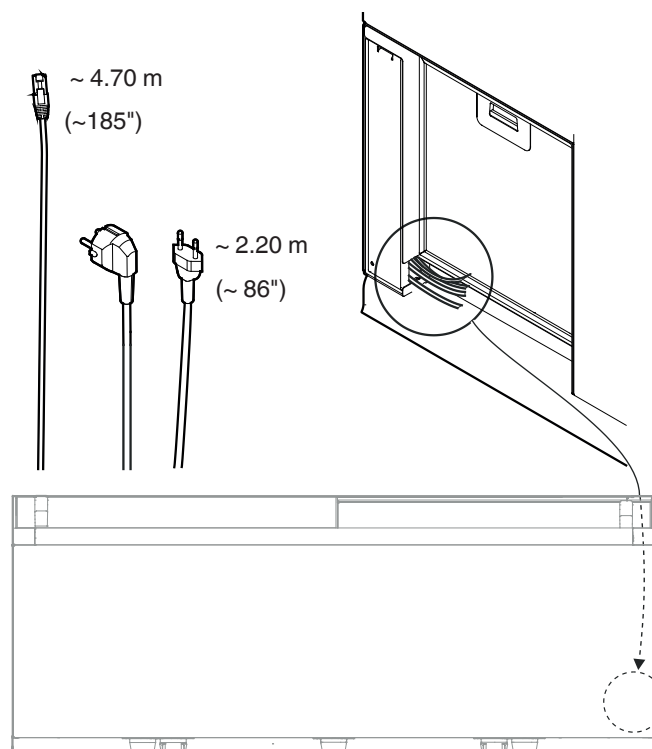

Requirements for assembly

The assembly must comply with the applicable regulations, standards, directives and laws where they apply to the subject of the contract.

Work on the electrical system (electrical connection, cable duct or sockets) may only be carried out by a qualified electrician.

Note

To avoid the assembly work being delayed or even stopped, installation of the appliances should be carefully planned in advance. It must be ensured that all the requirements are satisfied.

Requirements for the place of installation

Ensure that the place of installation for assembling the appliances is suitable and properly prepared.

- Any existing old appliances must be removed and disposed of in an environmentally friendly manner.
- The place of installation must be free of dirt and moisture.
- The evenness of the floor surface must comply with the usual limit values for evenness deviations set out in DIN 18202.
- The ambient temperature must correspond to the climate rating. The climate rating applicable to your appliance is shown in the operating instructions.
- Any display unit above the appliance must be straight and perpendicular, and must not contain any goods.
- Any positioning rails must be installed to meet the plinth foot spacings of the appliances.
- If a collision guard or positioning rails (accessories) are installed, approval must be obtained from a qualified body to drill holes in the floor. It must be ensured that no cables or pipes (e.g. underfloor heating) in the floor are damaged.

Requirements for the electrical connection

- We recommend that separate circuits are installed for the lighting and chest refrigeration units. The sockets must be clearly distinguishable.
- Two sockets must be prepared for each appliance for these two circuits. The sockets must be permanently fixed and clearly labelled.
- Each appliance must be protected by its own fuse.
- A separate fuse must be provided for the lighting.



NOTICE

Do not connect the appliance using an extension cable or extension socket.

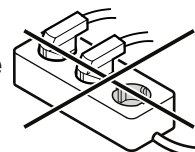

Requirements for a remote data transmission connection

- A bus socket (CAT 5 or CAT 6) must be provided for each block.

Bus connection

Up to 120 appliances with CAN and 247 with MOD bus can be networked and integrated into the in-house system using one or more coupling modules.

Addressing

Free addresses from the in-house system must be used to address the bus with one- to three-figure numbers (1-999) being allocated for this purpose.

The addresses are entered individually on each appliance, see "Assigning addresses to the appliances", page 29.

Each address may only be used once within the bus.

Depending on the system environment, we recommend that you use the appropriate coupling modules:

<p>Digital I/O Pin-Belegung 10pol Alarmkontakt: 1NC 2COM 6NO Eingang_ 4/5 Licht Ein 9/10 DI 2 optional CAN Bus Liebherr ST Pin-Belegung RJ-45: 2/7/8 BUS_L 3/6 GND 1/4/5 BUS_H</p>

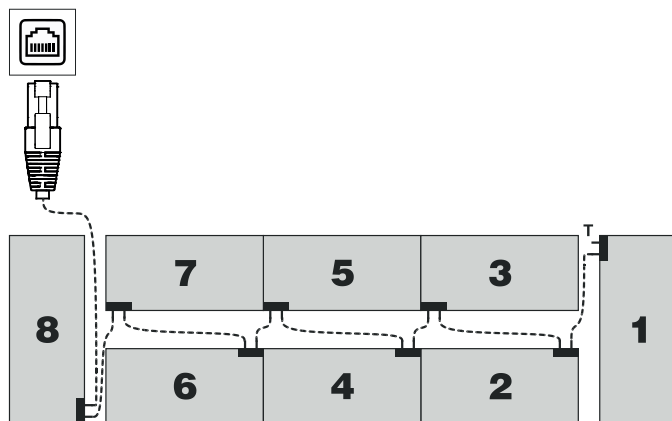
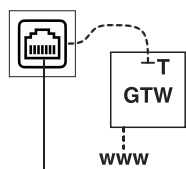

T.....Termination enabled

- If a repeater is used, the termination must be enabled.

Operation (LSC version only)

<p>Digital I/O Pin-Belegung 10pol Alarmkontakt: 1NC 2COM 6NO Eingang_ 4/5 Licht ein 9/10 DI 2 optional MODBUS RTU LSC Pin-Belegung RJ-45: 2/7/8 Data - 3/6 GND 1/4/5 Data + home.liebherr.com/lsc</p>

- The adjustment range of the address in menu A has been extended to 1-247.
- An additional baud rate/parity setting menu point "bd" has been included:
- Menu bd step 1: The set baud rate is displayed in [Bit/s * 10] and can be adjusted using the cursor keys. The two leading and the two following numbers in the baud rate flash alternately:
 09|60 = 9600 baud,
 19|20 = 19200 baud,
 38|40 = 38400 baud,
 56|00 = 56000 baud.
- The parity is set after confirmation by pressing the SET key. Meaning:
 E1 = Even parity + 1 stop bit,
 n2 = No parity + 2 stop bits,
 o1 = Odd
 n1 = No parity + 1 stop bit
- The setting is saved by pressing the SET key. A short acknowledgement tone means that nothing has been changed. A long acknowledgement tone indicates that the interface parameters have been changed.

Scope of delivery

Standard (per appliance)

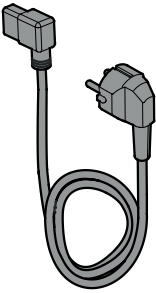
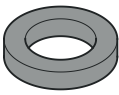
Quantity	Description
1	Appliance
1	Power connection cable (2.50 m) 
1	Release key 
1	Service type plate
1	Operating instructions

Accessories (depending on configuration)

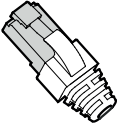
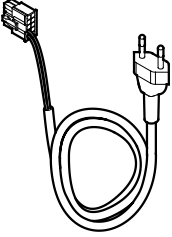
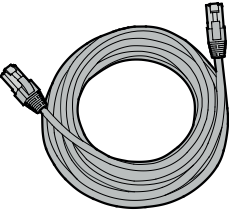
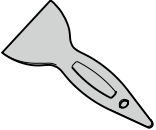
Quantity	Description
*	Terminating resistor (T = Termination) 
	Light cable for manual control (2.50 m) 
*	Network cable (5 m) 
*	Ice scraper 
*	Service interface extension (2 m)
*	Protection strip
*	Shaped foam tape

*) depending on configuration

Accessories (optional)

Positioning aid: spacer

Positioning rail

Sealing strip

End-of-aisle appliance connection kit

Block completion with cover plate (without end-of-aisle chest)

Protection strip for longitudinal appliances

Protection strip without end-of-aisle chest

Protection strip with end-of-aisle chest

Cover for block configuration

Cover for wall mounting

Product plate holder

Corner protection

Plug set for alarm output

End-of-aisle appliance collision guard

Collision guard for block completion with cover plate

Collision guard for longitudinal chests

Transport and unpacking

The appliance is supplied fully assembled standing on a pallet.

Check the appliance for transport damage before and while unpacking it. Report any damage (loose parts, dents, scratches, visible fluid leaks, etc.) without delay.

Remove the packaging and check that the delivery is complete.

Ensure that the appliance is not damaged while it is being transported and unpacked.

⚠ WARNING
Danger of suffocation due to packing material and plastic film!
Do not allow children to play with packaging material.
Dispose of the packaging material in compliance with current regulations.

Moving the appliances to the place of installation



Wear safety shoes!



Wear gloves!

Move the appliances to the place of installation on the pallets using suitable equipment.

Notice

Ensure that the appliances are not damaged while they are being transported and unpacked.

Position the appliances in a line in the required configuration. If an end-of-aisle appliance is included in the configuration, start with this.

If the appliances are to be installed in a block, arrange them in parallel.

Lifting the appliances off the pallet

At least two people are required for this.

Lift the appliances off the pallets using suitable equipment and carefully lower them into position.

Leave enough space to the display unit above the appliances (if there is one) and between them so that subsequent work can be carried out with plenty of space. Do not push the appliances together until later.

Possible configurations

Note

The “Requirements for the place of installation”, page 4 and the “Requirements for the electrical connection”, page 4, must be complied with for all configurations.

If the appliances are networked, the “Requirements for a remote data transmission connection”, page 5, must also be complied with.

Installing an individual appliance

Every model can be installed individually.

1. “Fitting the sealing strip”, page 10
2. “Fitting the cables”, page 11
3. “Cover for wall mounting”, page 27
4. **Positioning the appliance**

Position the appliance at a distance measured on the floor of at least $A = 5 \text{ cm}/1.97''$ from the rear limit surface (e.g. the wall).

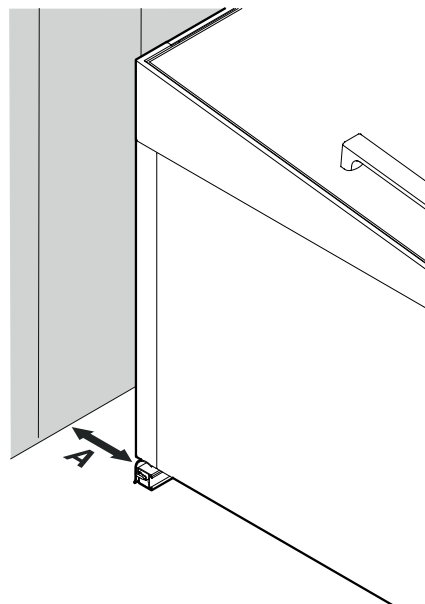

Notice

The air circulation must not be hindered.

5. “Connecting appliances”, page 15
6. “Fitting the protection strips”, page 20
7. “Commissioning the appliances”, page 30

Installing appliances in a row

1. "Fitting the sealing strip", page 10
2. "Fitting the cables", page 11
3. "Affixing shaped foam tape", page 10
4. "Cover for wall mounting", page 27
5. **Positioning the appliances**

Position the appliances side by side at a distance measured on the floor of at least $A = 5 \text{ cm}/1.97''$ from the rear limit surface (e.g. the wall) and push them together without leaving a gap between them.

Notice

When pushing the appliances, it is vital that you ensure that no cables are jammed or damaged.

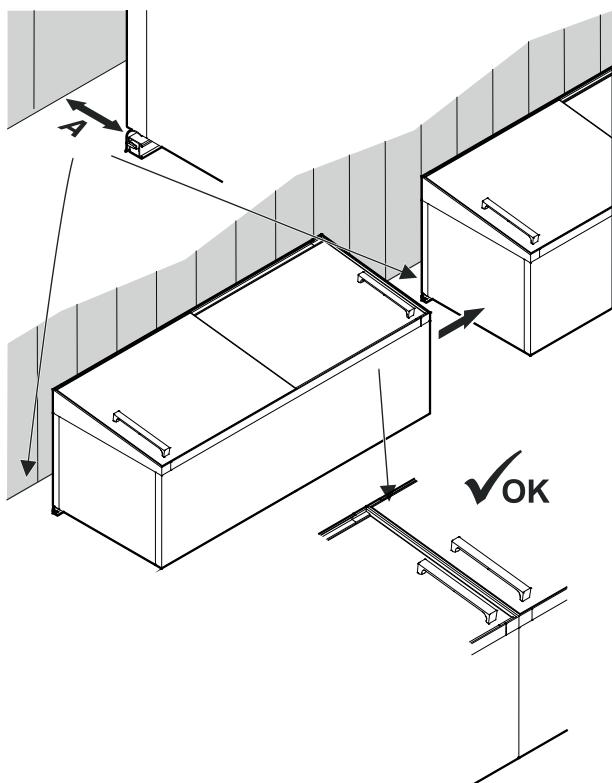

Notice

The air circulation must not be hindered.

6. "Connecting appliances", page 15
7. "Fitting the protection strips", page 20
8. "Assigning addresses to the appliances", page 29
9. "Commissioning the appliances", page 30

Installing the appliances in a block or in island form

1. "Fitting the sealing strip", page 10
2. "Fitting the cables", page 11
3. "Affixing shaped foam tape", page 10
4. **Positioning the appliances**

Notice

When pushing the appliances, it is vital that you ensure that no cables are jammed or damaged.

A) Without positioning rails

Place the appliances in the row in a straight line. Arrange the opposite row parallel to the first one.

The distance between the rows must be at least $A = 10 \text{ cm}/3.94''$ (measured at the bottom appliance edges).

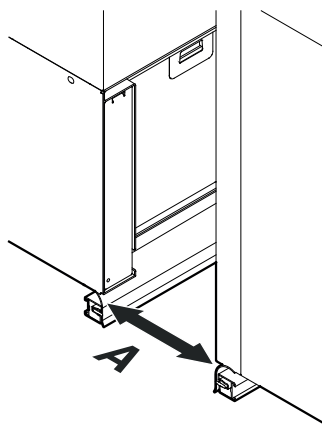

B) With magnetic positioning aid

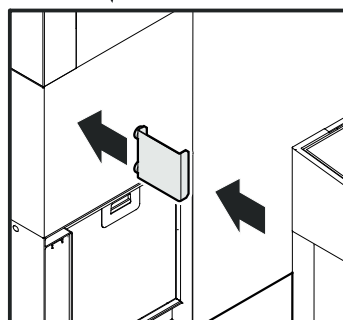
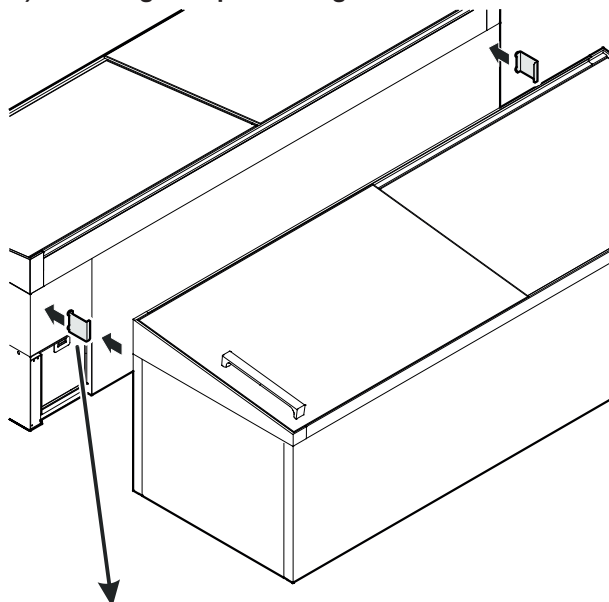

Notice

The air circulation must not be hindered.

C) With positioning rails

Install the positioning rails in a straight line the length of the block. The start and end may at most be flush with the first or last appliance.

Notice

Approval must be obtained from a qualified body to drill holes in the floor. It must be ensured that no cables or pipes (e.g. underfloor heating) in the floor are damaged. The fastening material (screws, plugs and adhesive tape) is not supplied and must be selected to suit the site conditions.

Fix the positioning rails to the floor.

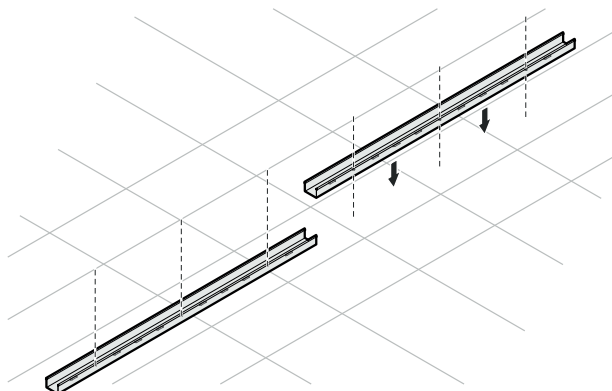

Position the appliances so that the rear touches the positioning rails.

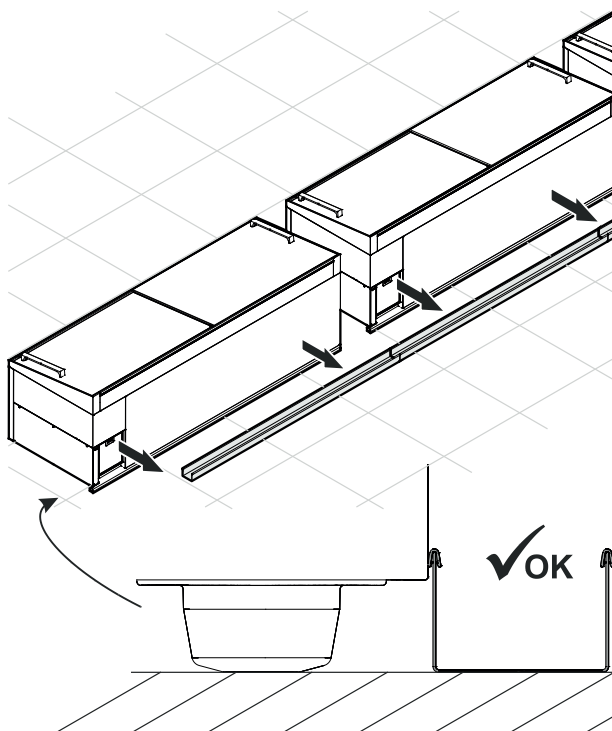

Push the appliances together with no gaps between them.

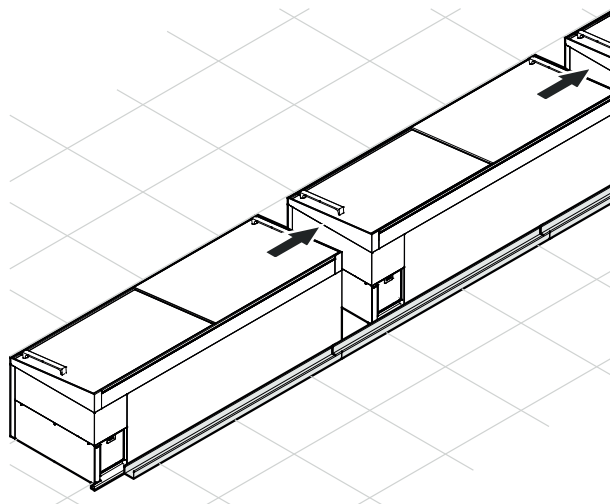

Install the opposite row in the same way ensuring that the appliances are parallel to each other.

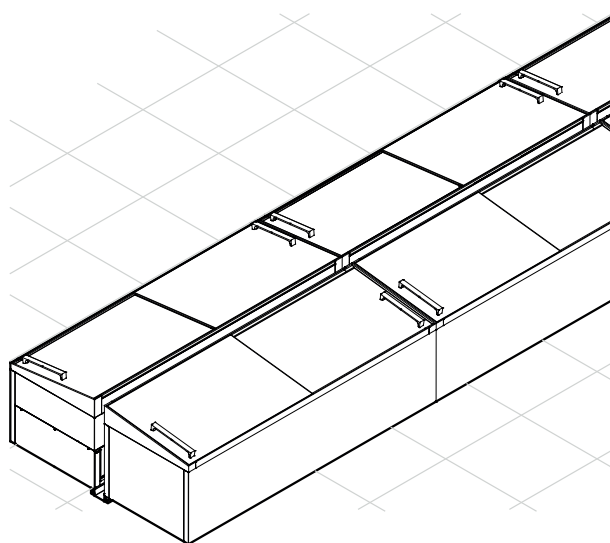

5. "Connecting appliances", page 15
6. **Completing the end of the block:**
 "End-of-aisle appliance connection kit", page 15
 or
 "Block completion with cover plate (without end-of-aisle chest)", page 18
7. "Fitting the protection strips", page 20
8. "Cover for block configuration", page 25
9. "Assigning addresses to the appliances", page 29
10. "Commissioning the appliances", page 30

Installation and connection

Affixing shaped foam tape

Affix the shaped foam tape to the top and front sides of the appliances to keep the contact areas of appliances in rows or blocks free of dirt. This allows the appliances to be placed next to each other without gaps in between and also compensates for minor unevenness.

Note

Do not affix shaped foam tape to the outer side panels of the first and last appliance in the row.

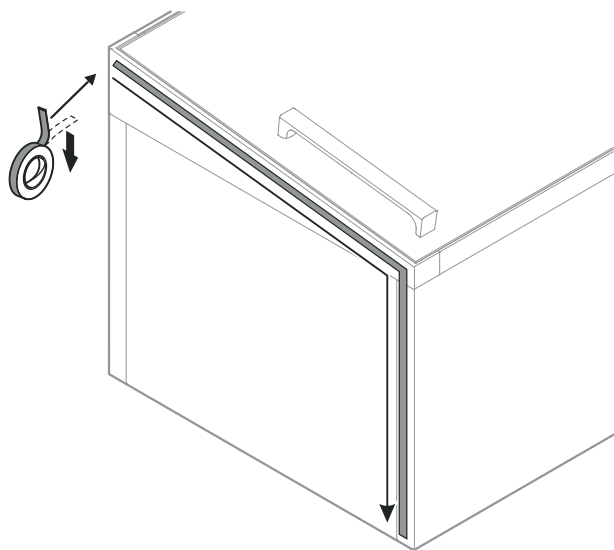

Fitting the sealing strip

Note

Only for appliances without a display unit above the appliances or positioning rails.

A) Alternative 1

1. Assemble the sealing strip.

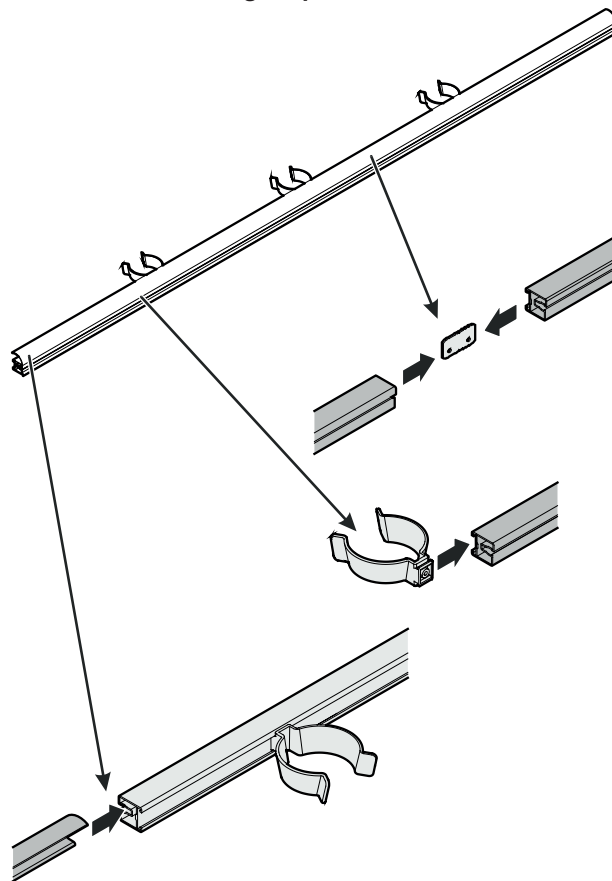

2. Fit the sealing strip.

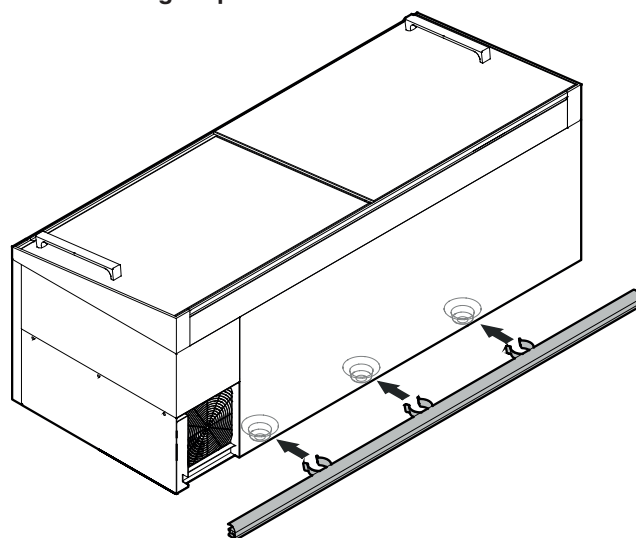

B) Alternative 2**1. Cut the foam moulding.**

For chest length 1800 mm and 2100 mm

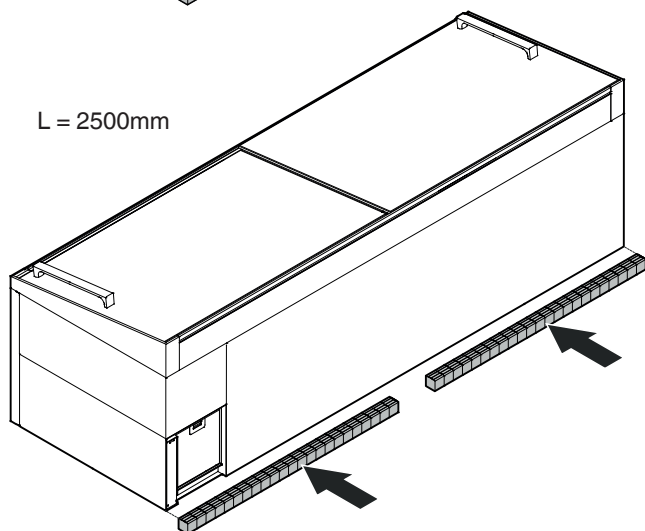
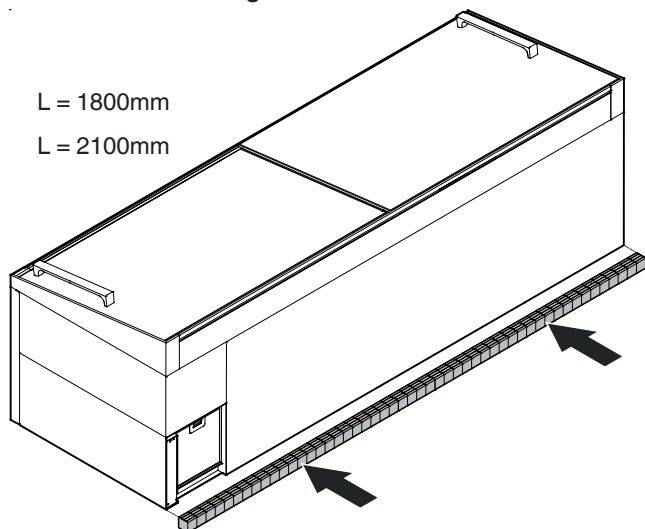
2. Fit the foam moulding.**Fitting the cables**

The cable connections are on the rear of the appliance under a cover.

Notice

The cables must be routed so that each appliance, including those in rows or blocks, can be pulled out individually without any problems for repair or service purposes.

Cables must not be jammed or damaged by this. Use any available cable suspension points.

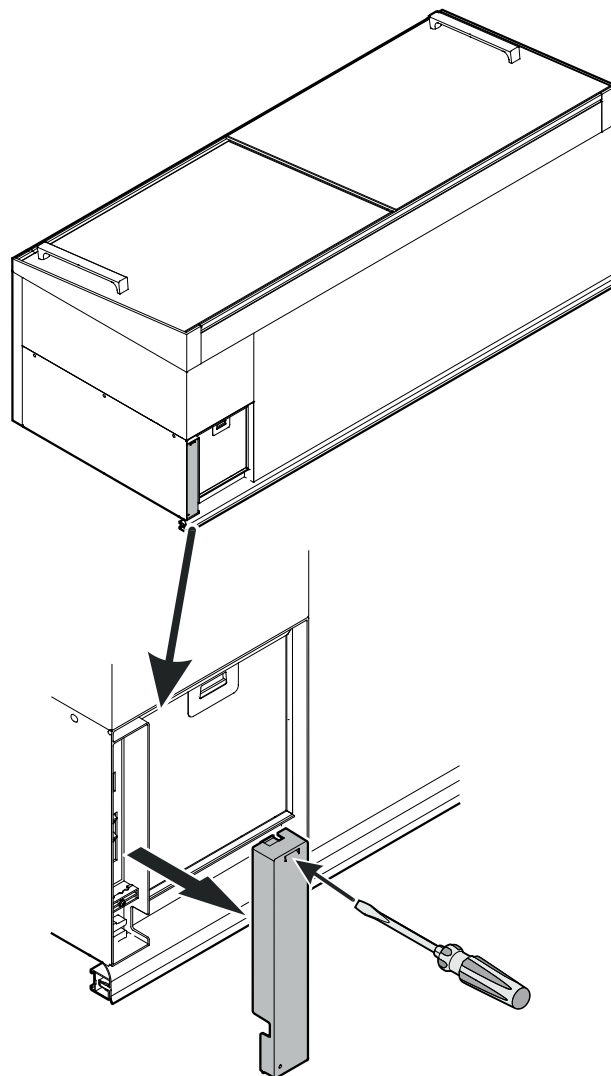
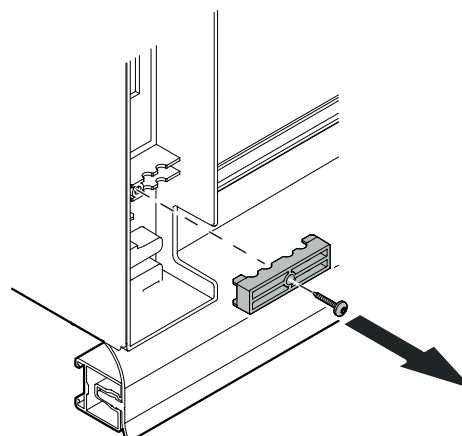
1. Remove cover.**2. Undo the screw and remove it together with the strain relief device.**

3. Connect the network cable.

Note

The ports (input/output) may be freely selected. The plugs must engage with an audible click.

First appliance

- Connect the terminating resistor.

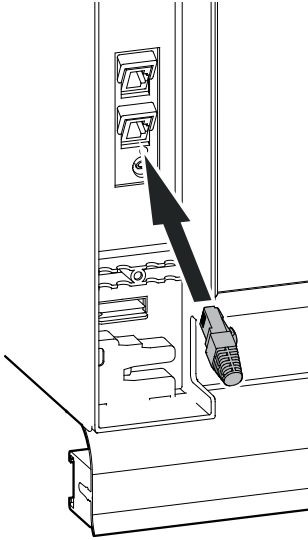

Additional appliances

- Connect one plug of the network cable (A).
- Connect the other plug of the network cable (A) to the next appliance.

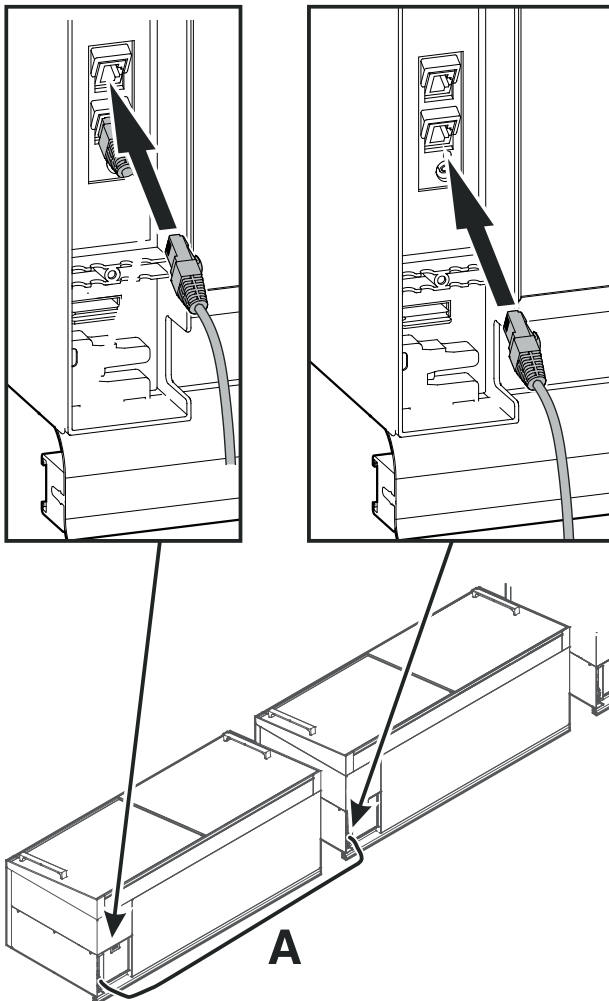

- To connect additional appliances, connect the plug of another network cable (B) to the second appliance and then connect it to the next appliance. Continue until all the appliances are connected.

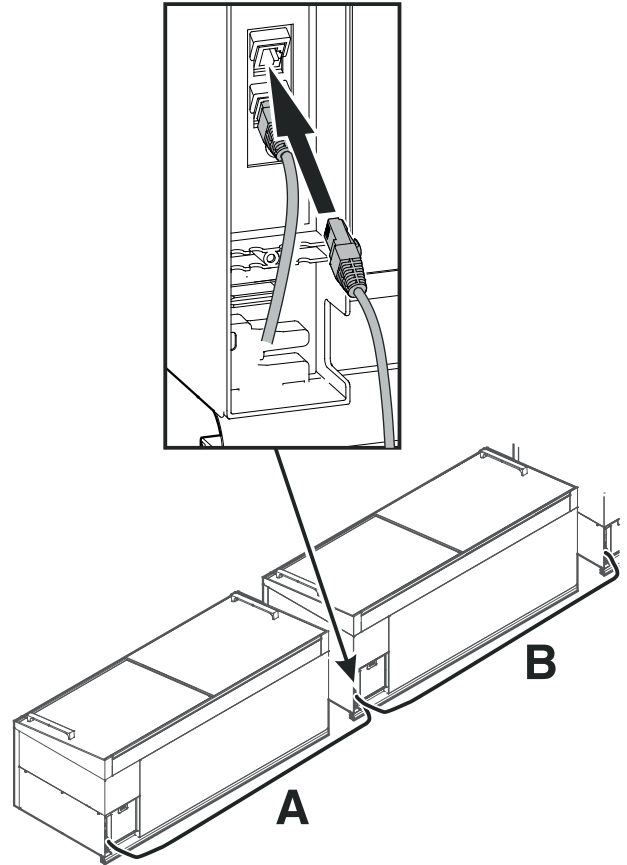

Note

The empty port on the last appliance in a configuration is used for connection to the coupling module and then to the in-house LAN.

Both bus ports must therefore be occupied on every appliance.

4. Connect the light cable plug.

See also “External alarm (floating alarm output)”, page 14.

Note

This plug does not need to be connected if the lighting is controlled via the network.

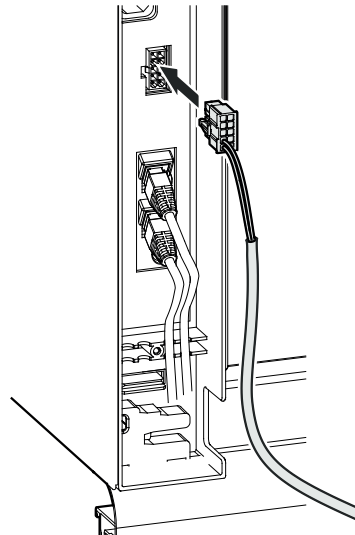

5. Connect the power connection cable plug.

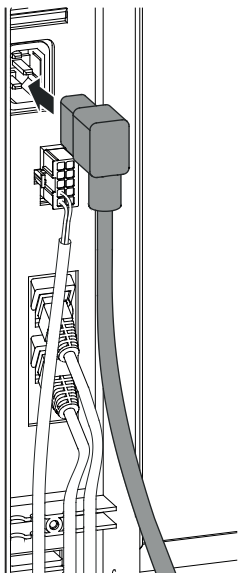

6. Fit the strain relief device, placing the cables in it. Insert screw.

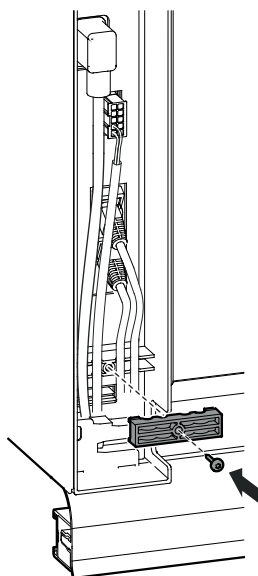

7. Fit the cover.

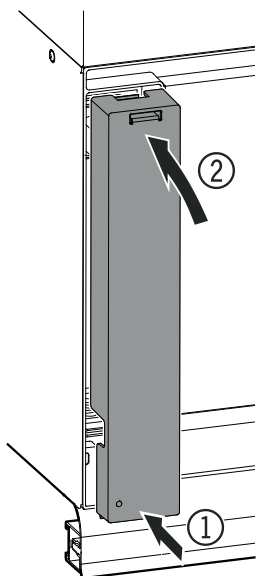

Fitting the service interface extension

The service interface is required to connect the test tool and for service work. It is on the rear of the appliances. To provide easier access, an extension can be fitted to a defined appliance (with easy access, e.g. the first appliance in the row).

Note

We recommend that the appliance with the extension is marked or documented to speed things up when service work is required.

1. Remove cover.

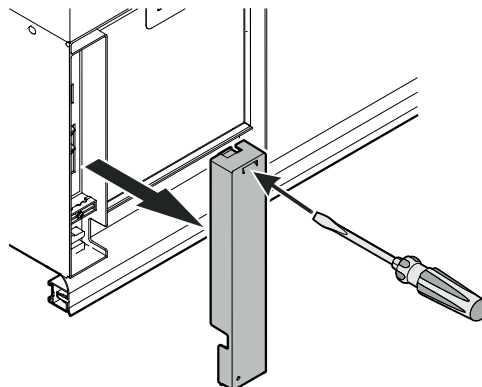

2. Connect the pawl plug, then route the cable upwards.

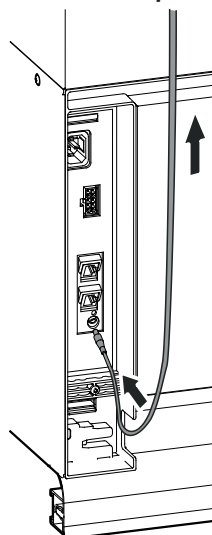

3. Fit the cover.

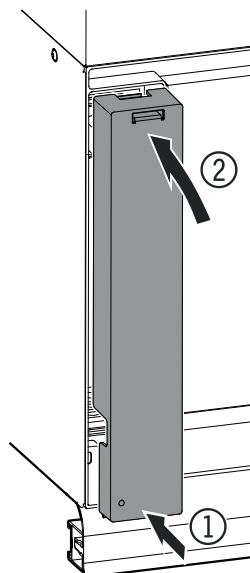

4. Fit the retaining element.

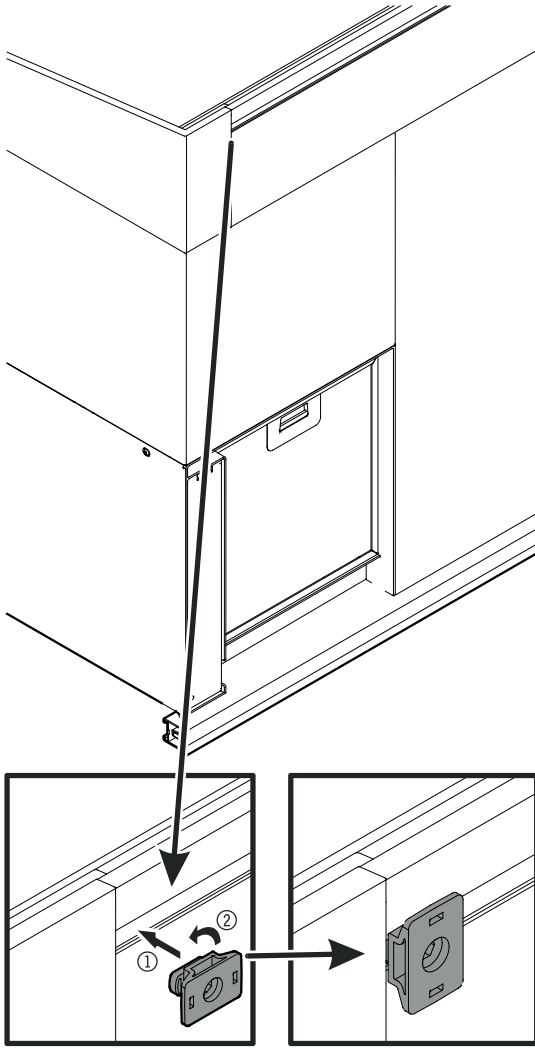

5. Secure the service interface to the retaining element using a cable tie.

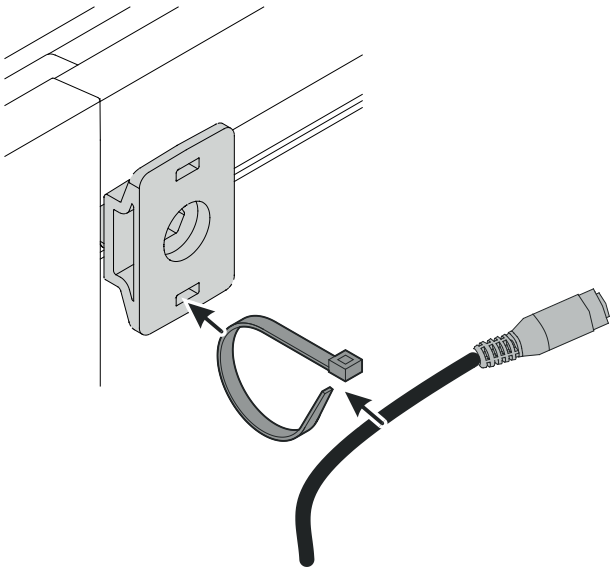

External alarm (floating alarm output)

It is possible to connect the appliance to an external alarm device.
Crimp contacts can be added to the light cable for this purpose.

Note

If there is no light cable (e.g. if the lighting is controlled via the network), a plug with crimp contacts is available separately, see "Accessories (optional)", page 6.

The contacts (NC, NO and COM) can be used to connect the appliance to an optical or acoustic alarm device.

The connector is designed for a maximum of 230 V AC/10 A or 24 V DC/5 A from a SELV (safety extra-low voltage) source (minimum current 150 mA).

Notice

When supplying mains voltage to the floating alarm contact, the technical safety requirements of standard EN 60335 will not be satisfied.

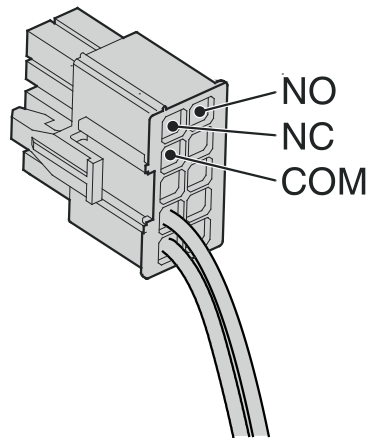

1	NC	6	NO
2	COM	7	free
3	free	8	free
4	Light IN (bn)	9	DIGITAL IN 230 V AC
5	Light IN (bu)	10	DIGITAL IN (neutral)

NC operating light

Connection for a control lamp to indicate that the appliance is in normal mode.

COM external power supply unit

Maximum 230 V AC/10 A or 24 V DC/5 A
Minimum current 150 mA

NO alarm output

Connection for a visual warning light or an acoustic alarm signal.

Connecting appliances

If separate circuits are used for lighting and cooling, the relevant sockets must be clearly labelled.

1. Plug the mains plug of the power connection cable into the appropriate socket.

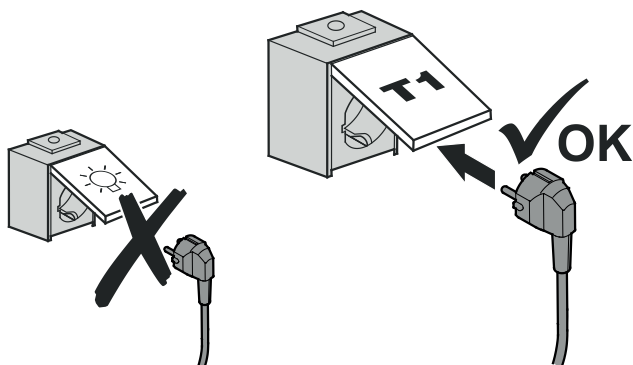

2. Plug the mains plug of the light cable into the appropriate socket.

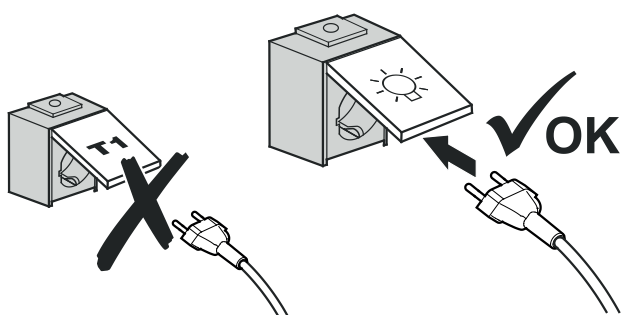

WARNING

If the mains plug of an appliance is accidentally placed into a lighting socket, when the circuit for the lighting is switched off (e.g. at night), the cooling function will no longer work and the food inside the appliance will be spoiled.

End-of-aisle appliance connection kit

To achieve an attractive connection of the end-of-aisle appliance to the block of appliances, fit the parts of the "End-of-aisle appliance connection kit" which is available as an accessory.

1. Affix the stickers.

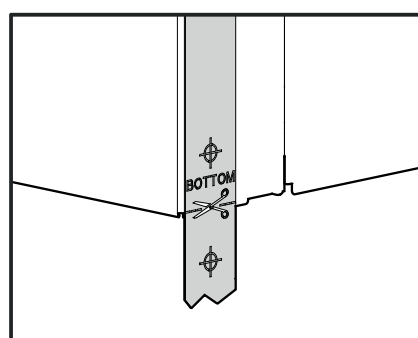
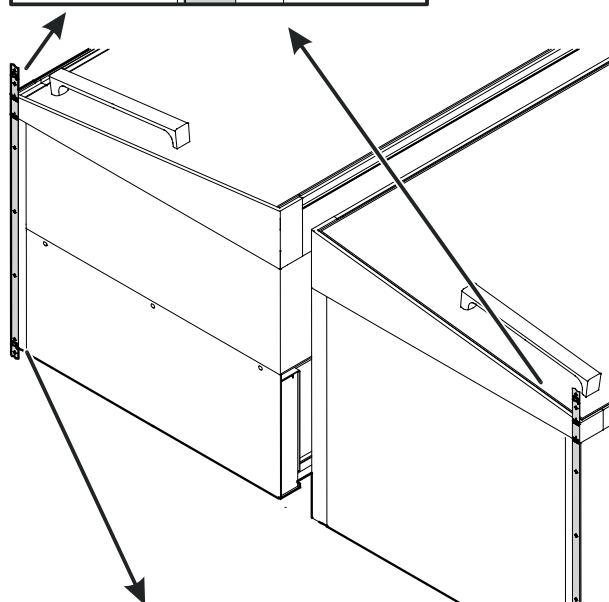
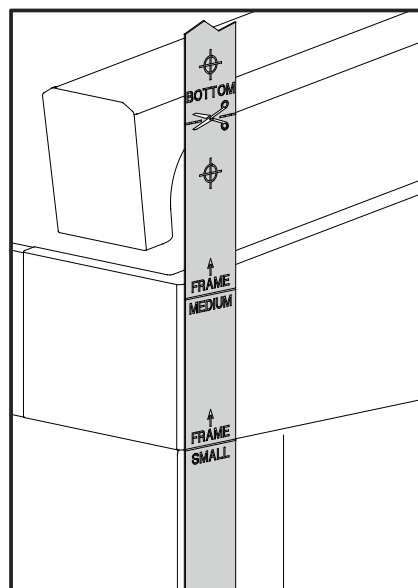

2. Pre-punch holes for the assembly bolts in the stickers using a nail.

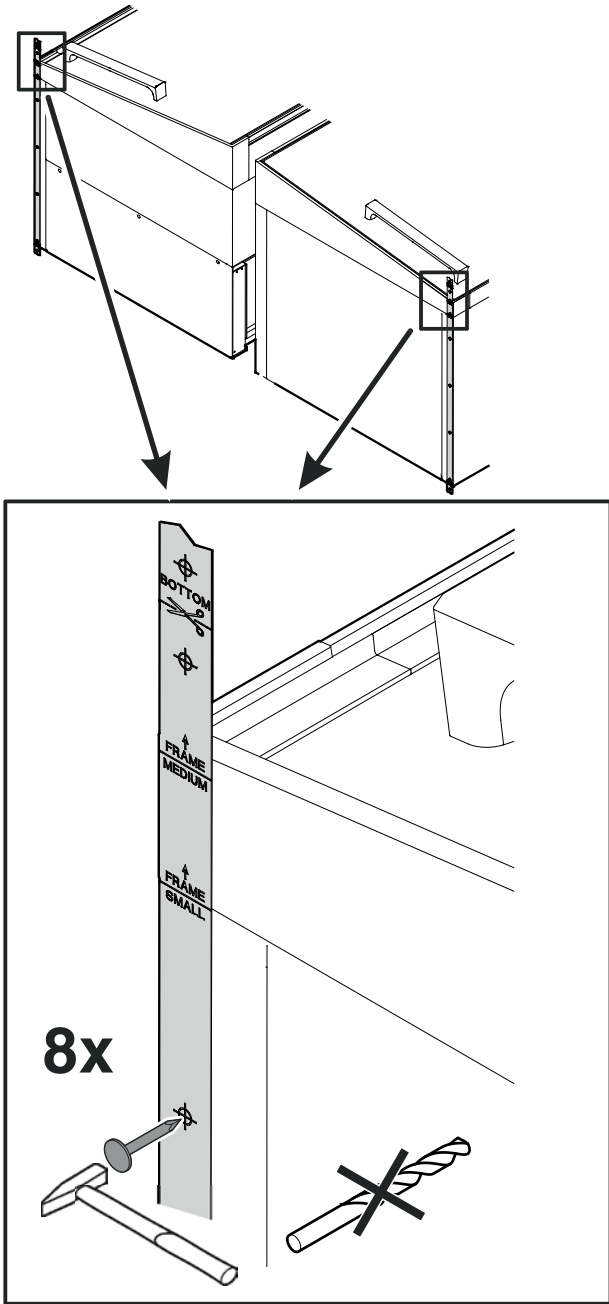

3. Screw assembly bolts into the block end appliances.

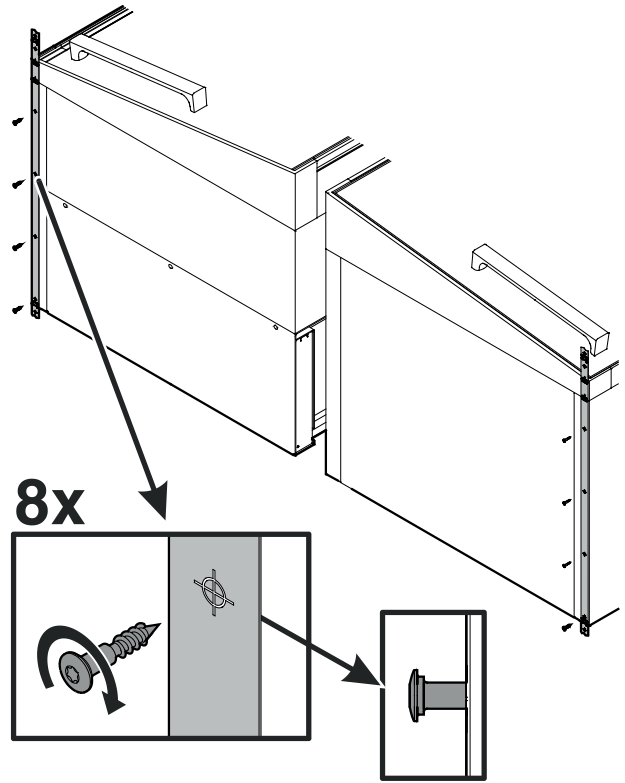

4. Check: assembly bolts are pre-assembled on the rear of the end-of-aisle appliance.

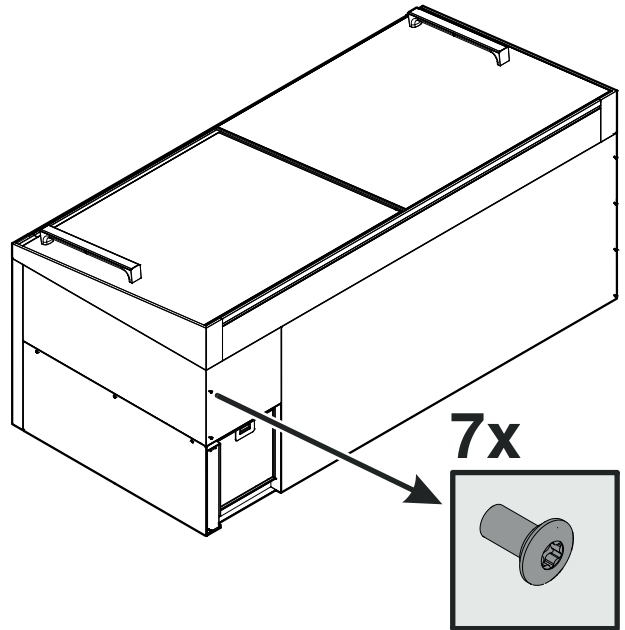

5. Fit the retaining elements to the end-of-aisle appliance.

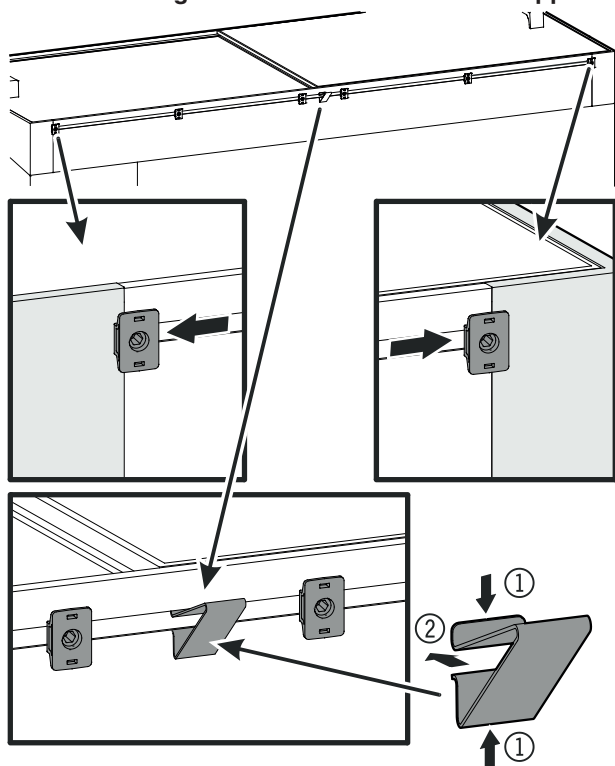

6. Push the end-of-aisle appliance up to $A = 6 \text{ cm}/2.36''$ against the block end appliances.

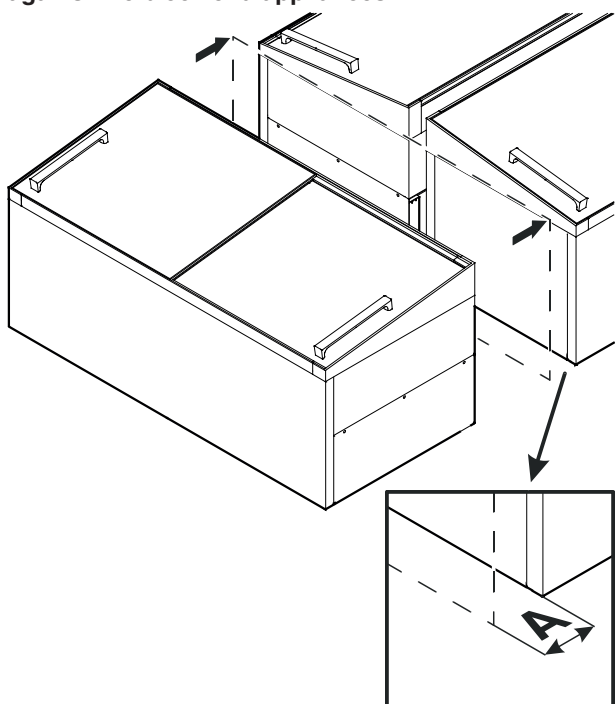

7. Fit the end-of-aisle appliance connection kit.

Attach the side pieces to the assembly bolts on the block end appliances and on the end-of-aisle appliance, then press them downwards.

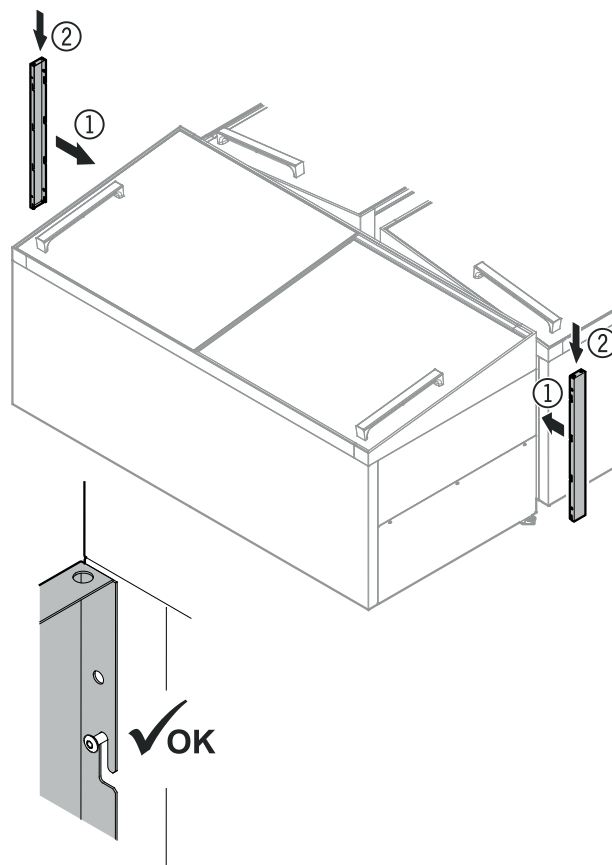

8. Fit the cover caps to the connection plates.

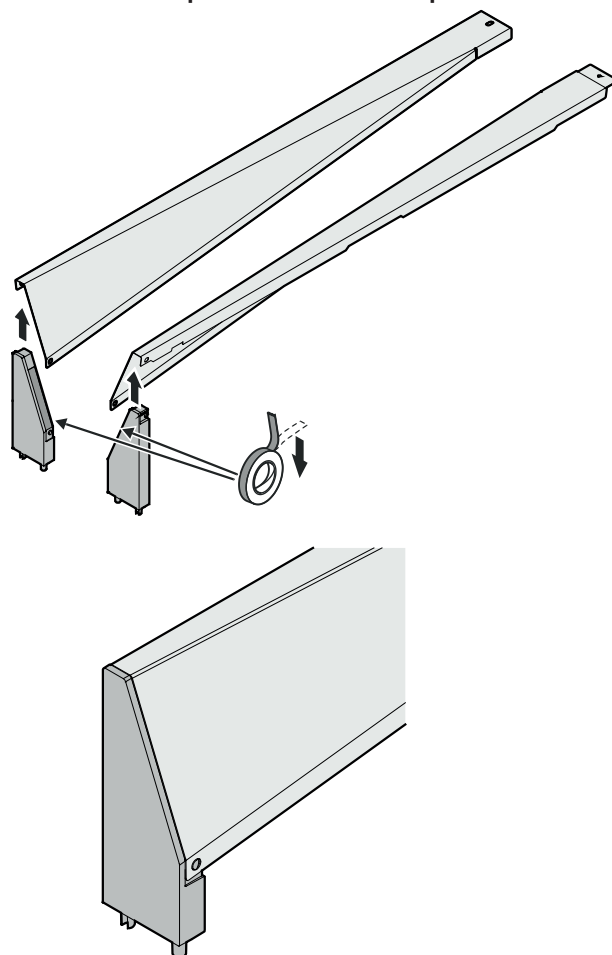

9. Fit the end-of-aisle appliance connection kit.

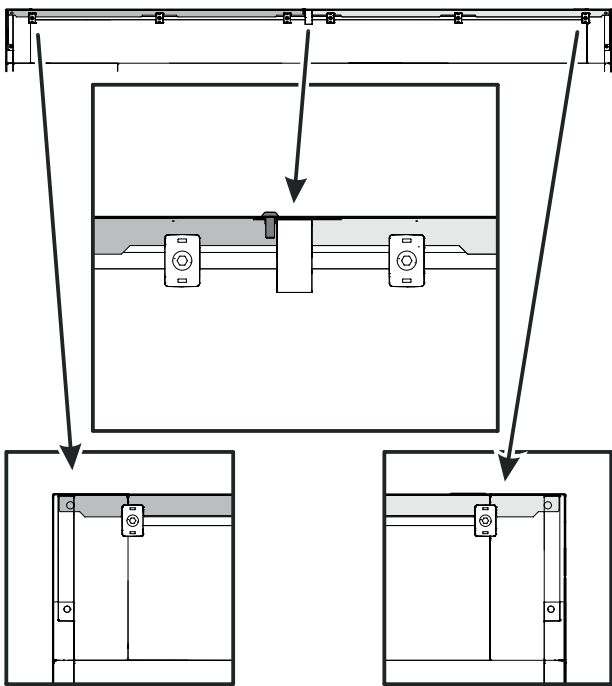
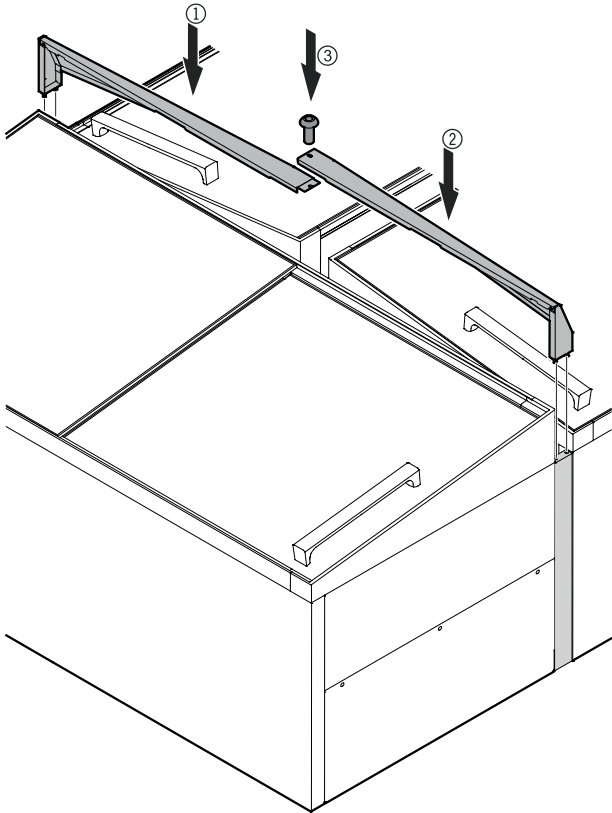

Block completion with cover plate (without end-of-aisle chest)

If there is a display unit above the appliance, no posts may project over the end of the block.

1. Affix the stickers.

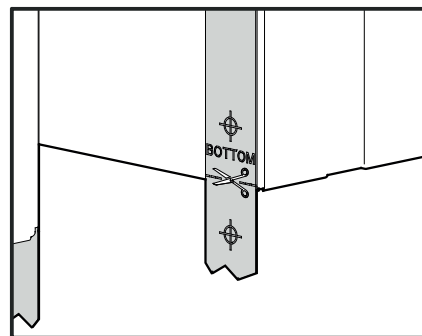
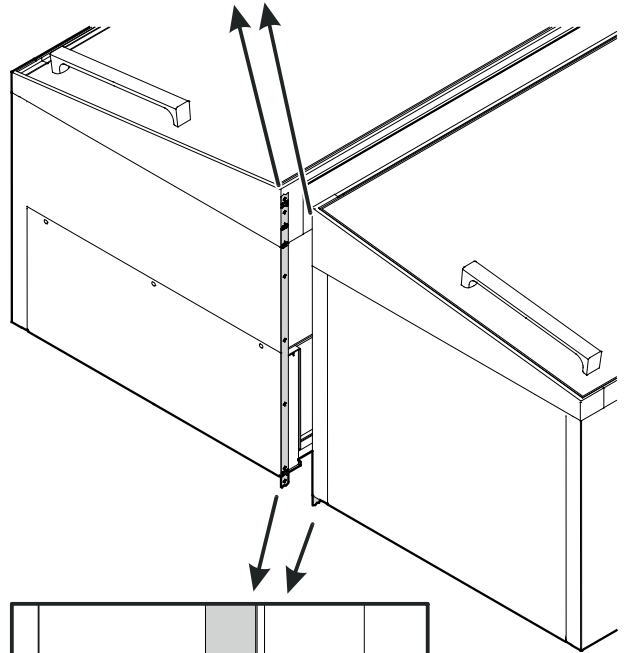
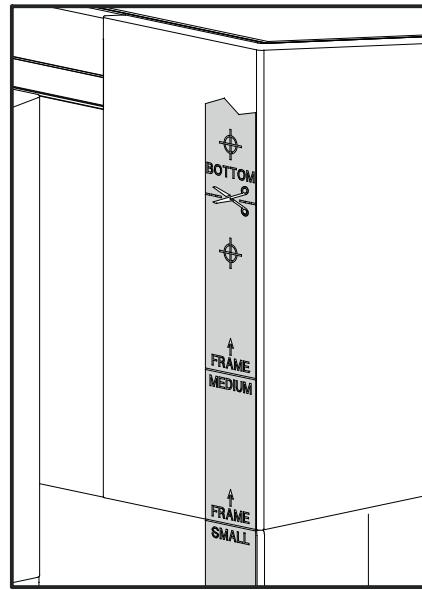

2. Pre-punch holes for the assembly bolts in the stickers using a nail.

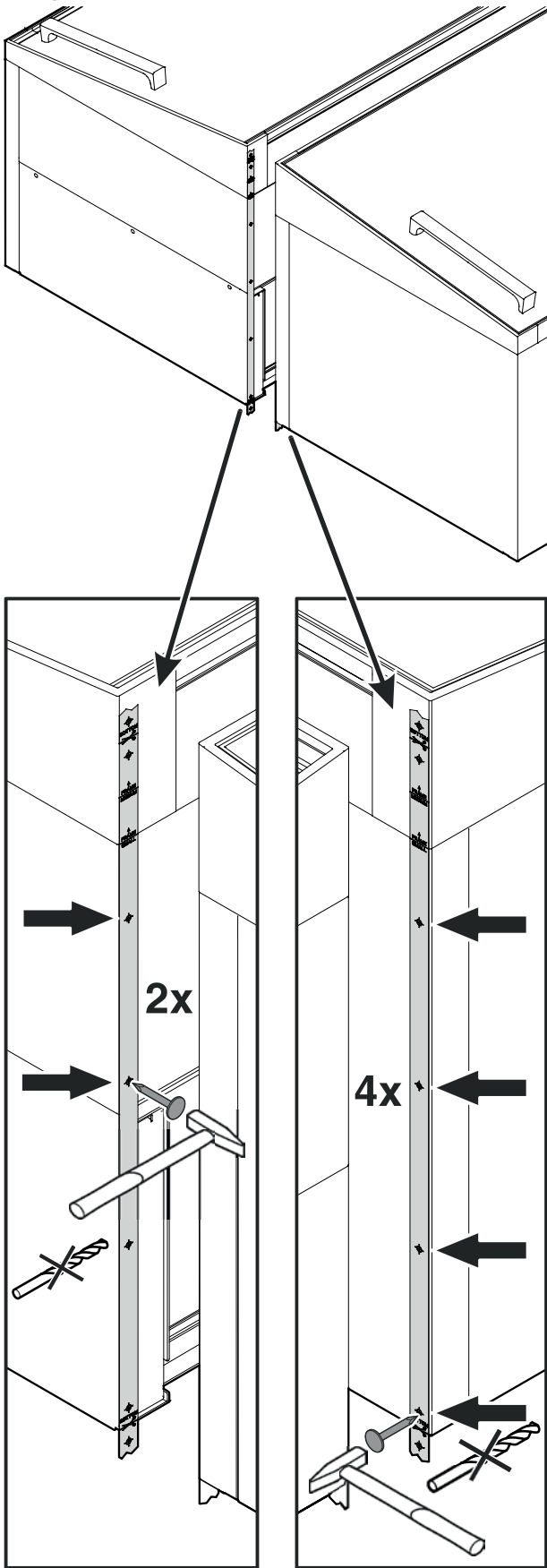

3. Screw assembly bolts into the block end appliances.

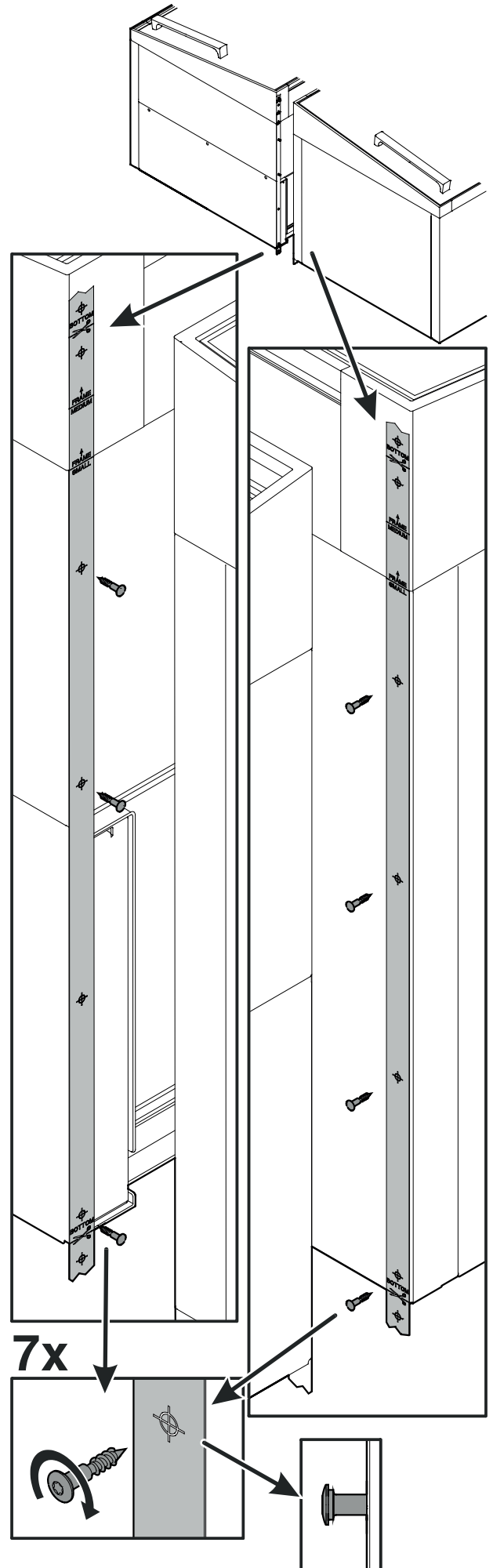

4. Attach the cover plate to the assembly bolts, then press downwards.

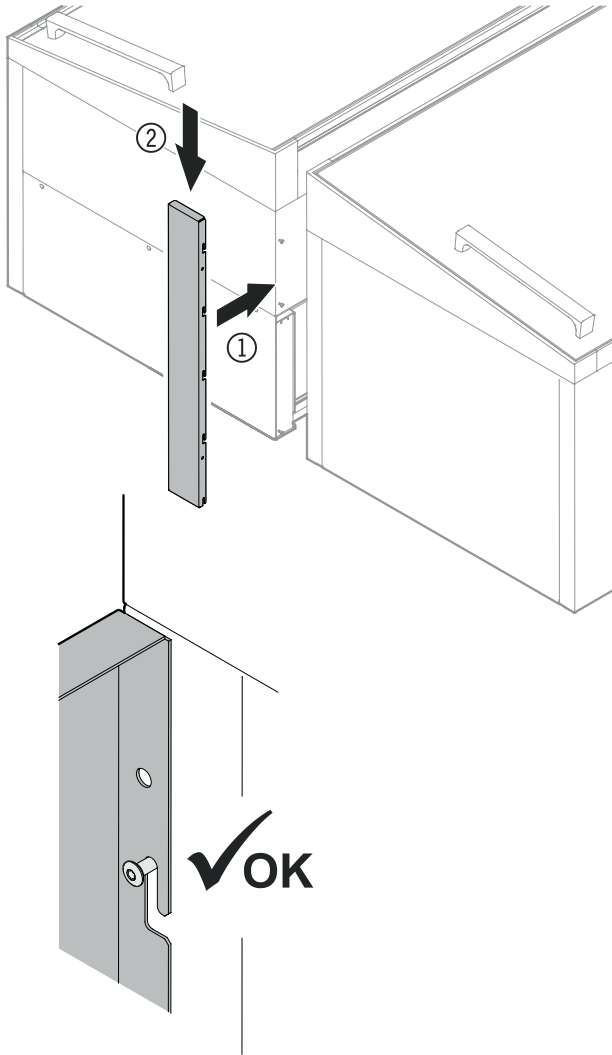

Fitting the protection strips

Individual appliance

Assembling the profile strip

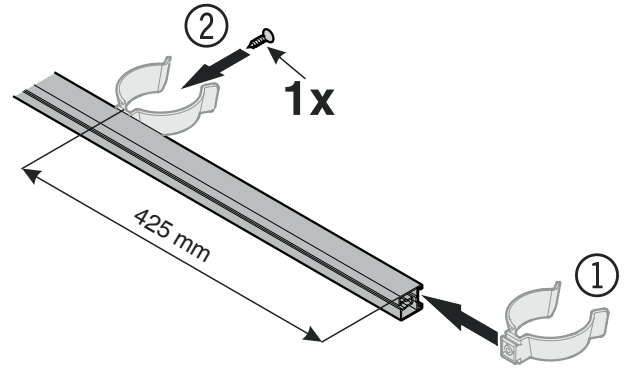

Protection strip for longitudinal appliances

A) Without lateral protection strip

1. Fit profile strip.

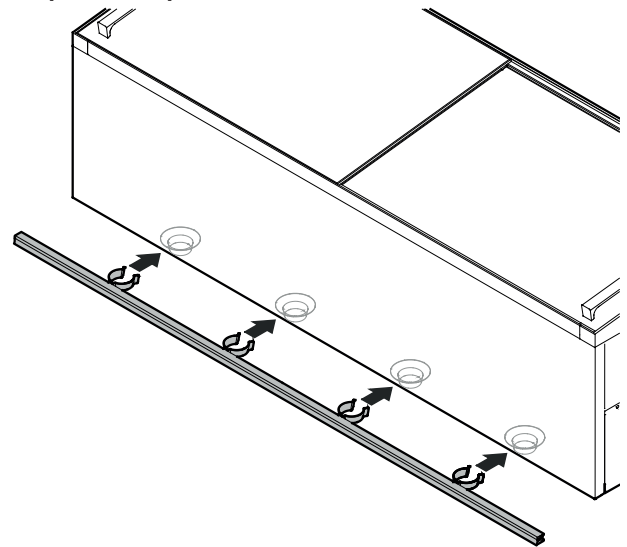

2. Fit protection strip.

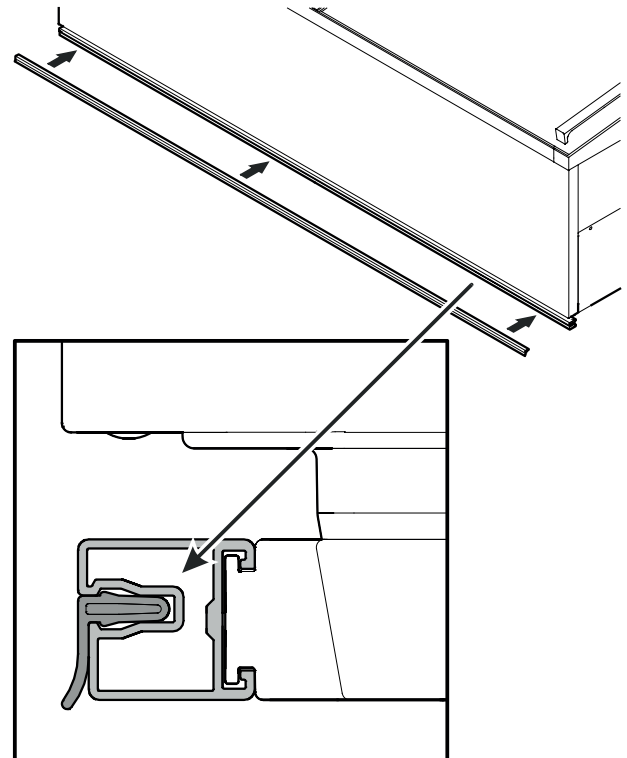

B) With lateral protection strips

1. Cut profile strip to the right length on both sides
A = 3 mm/0.12".

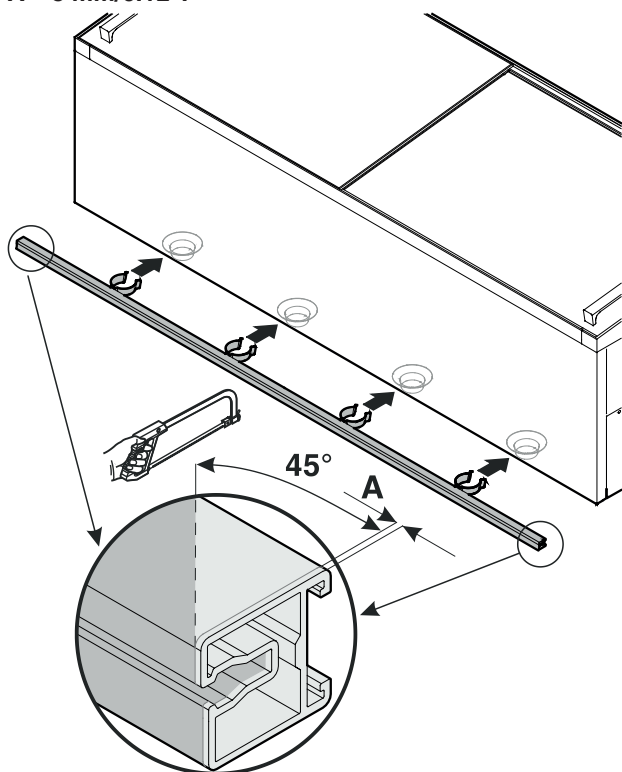

2. Shorten rear sealing strip by A = 34 mm/1.3".

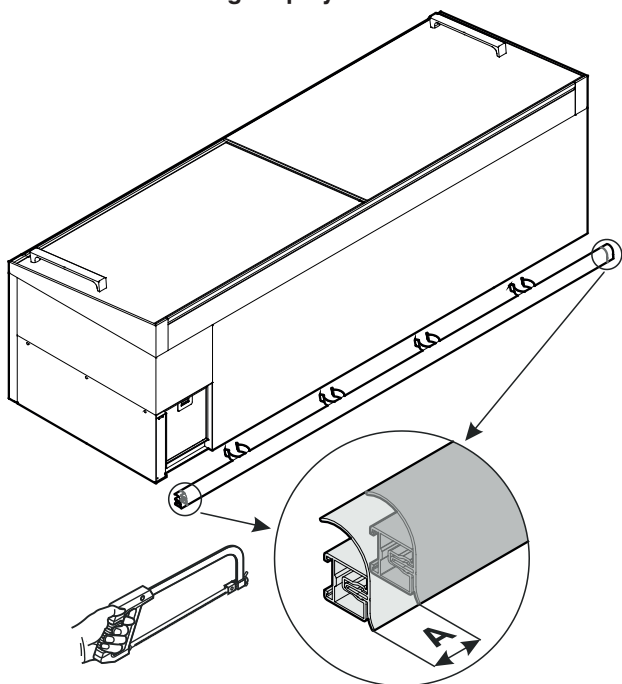

3. Fit brackets to lateral profile strips.

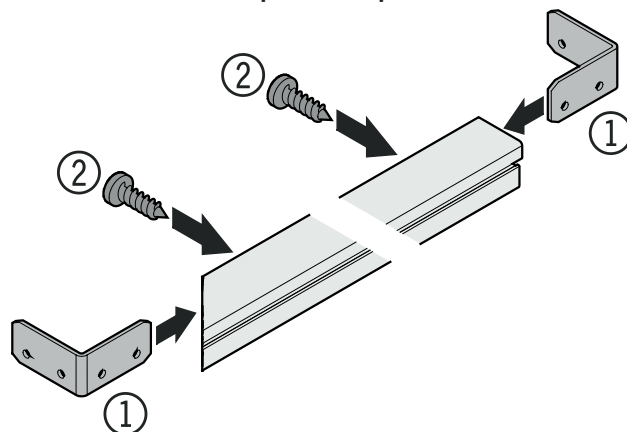

4. Fit lateral profile strips.

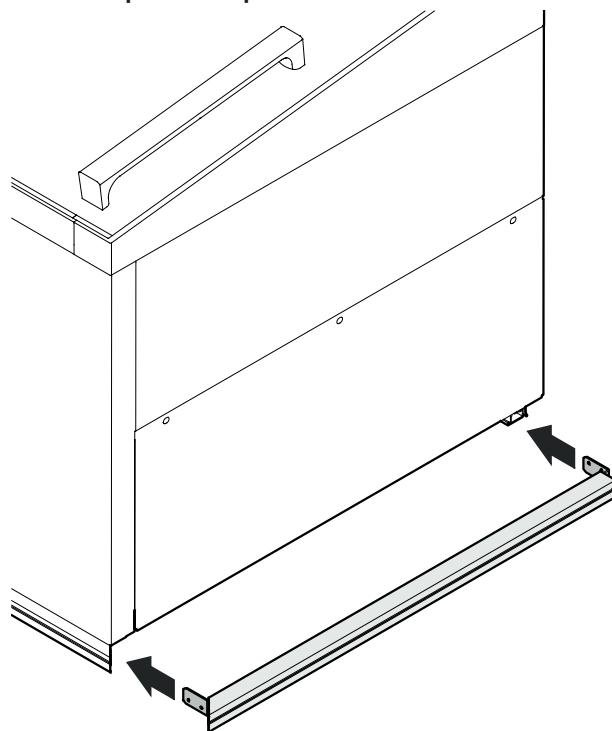

5. Fit protection strips.

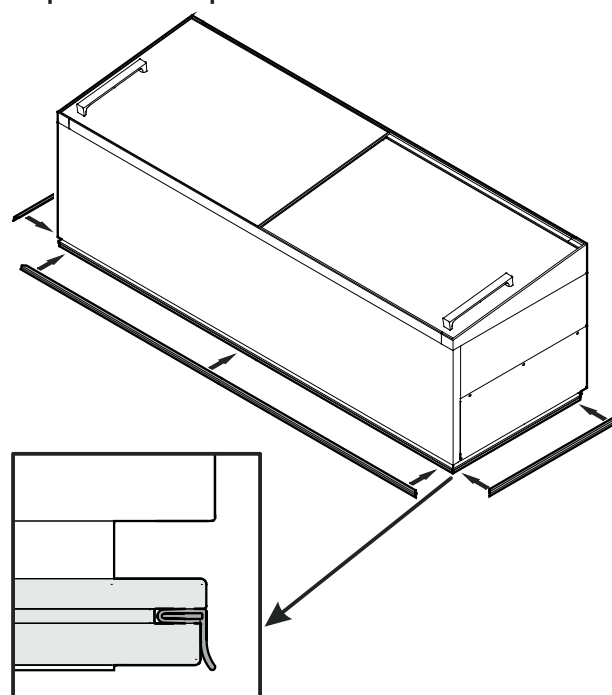

Row configuration

1. Connect profile strips.

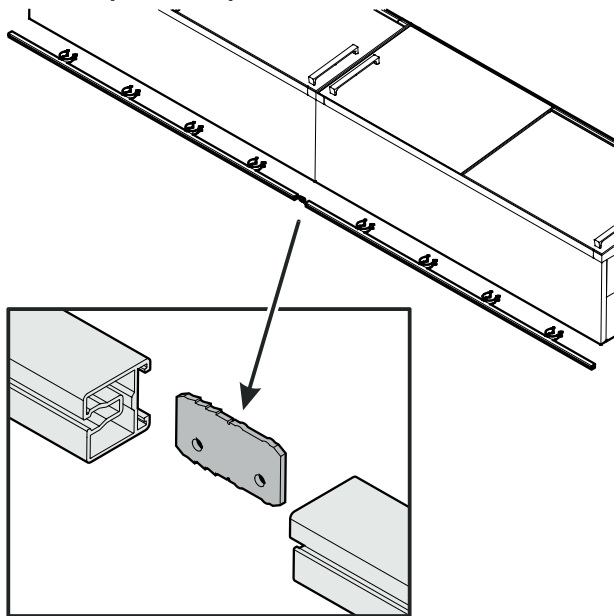

2. Shorten rear sealing strip at the row ends by $A = 34 \text{ mm}/1.3''$.

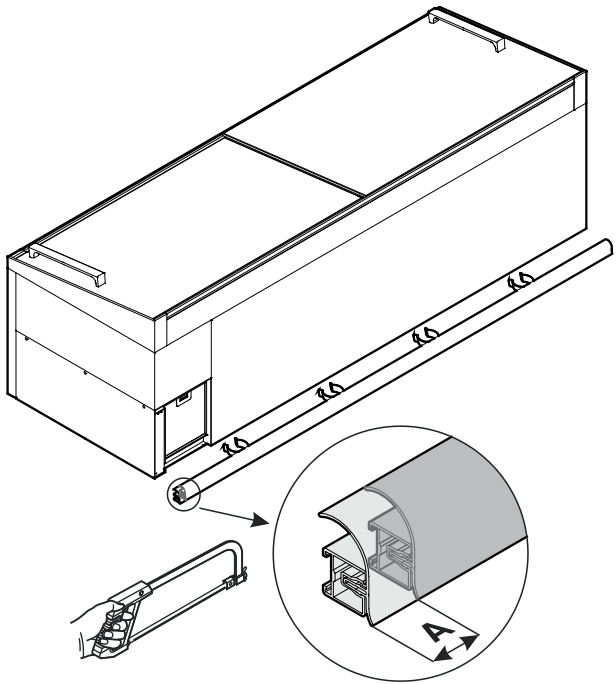

3. Fit brackets to lateral profile strips.

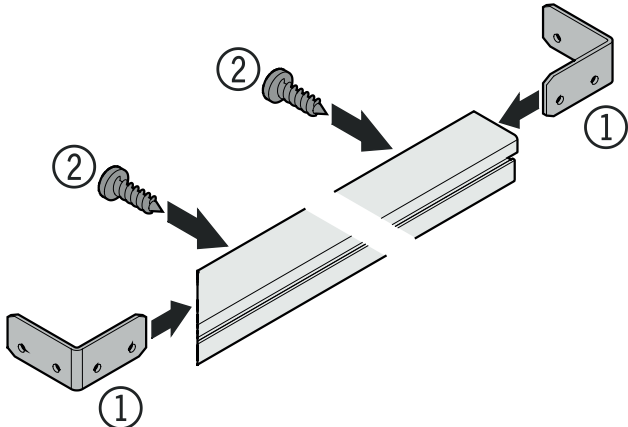

4. Fit lateral profile strips.

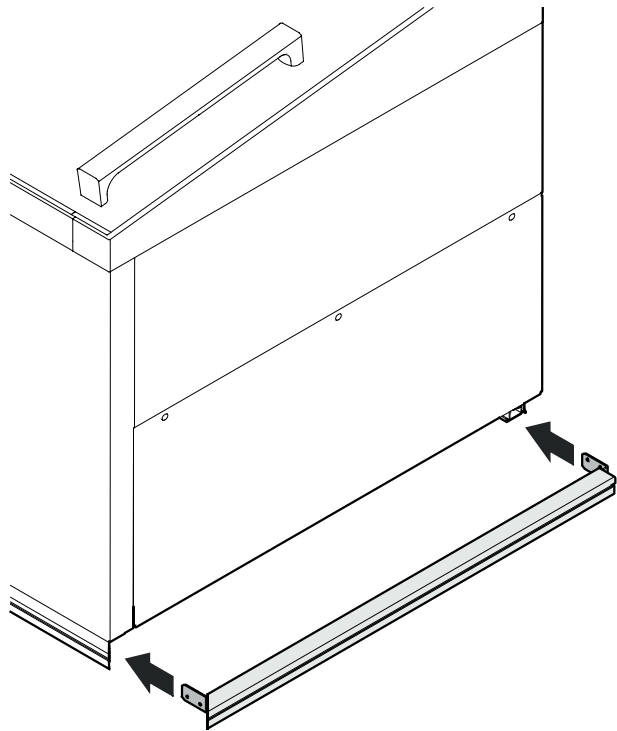

5. Fit protection strips.

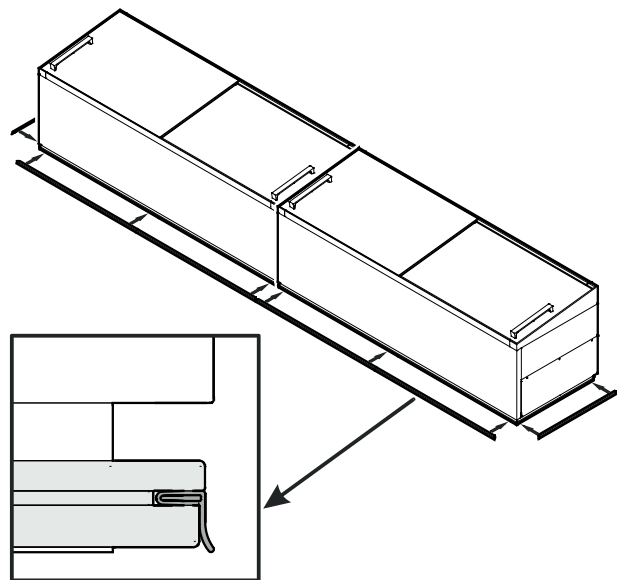

Block configuration

Protection strips for when there is no end-of-aisle chest

1. Cut profile strip to the right length on both row ends
 $A = 3 \text{ mm}/0.12''$.

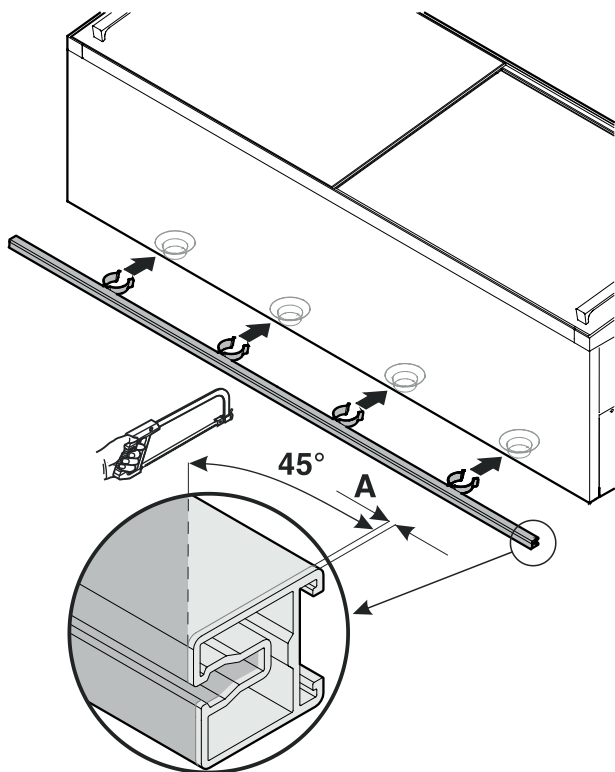

2. Shorten rear sealing strip at the row ends by $A = 34 \text{ mm}/1.3''$.

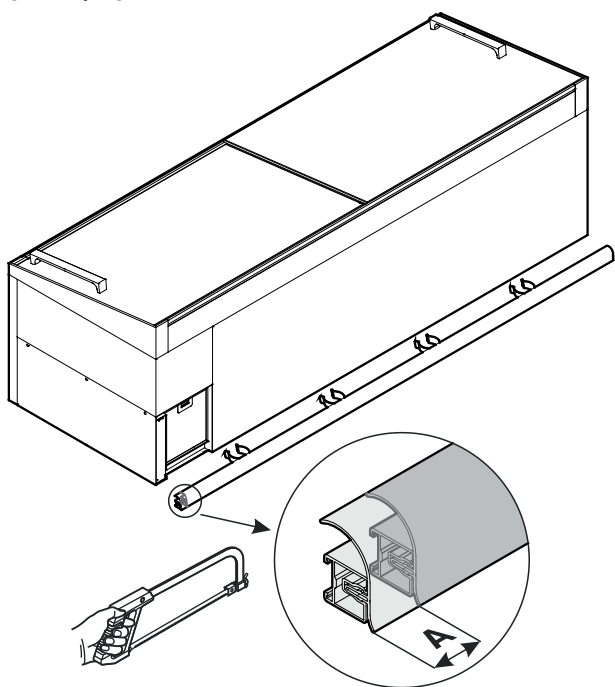

3. Fit brackets: $A = 781.5 \text{ mm}/30.77''$.

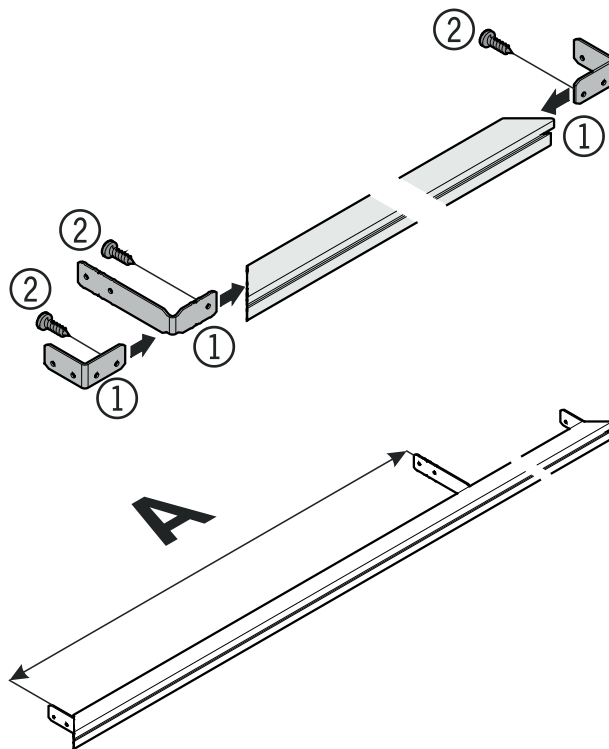

4. Fit profile strips.

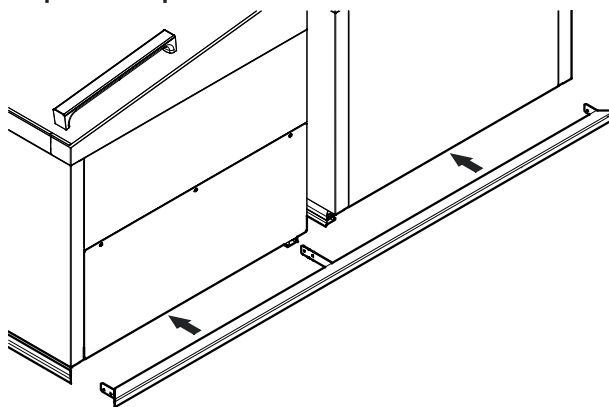

5. Fit protection strips.

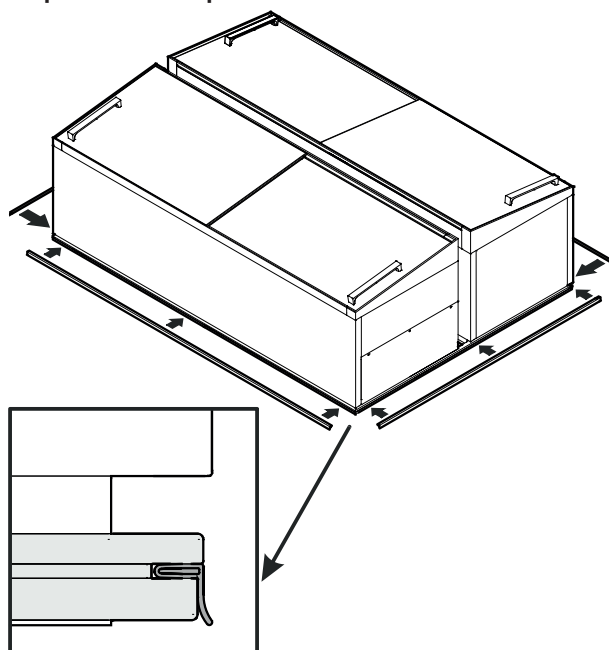

Protection strips when an end-of-aisle chest is installed

1. Fit connection plates.

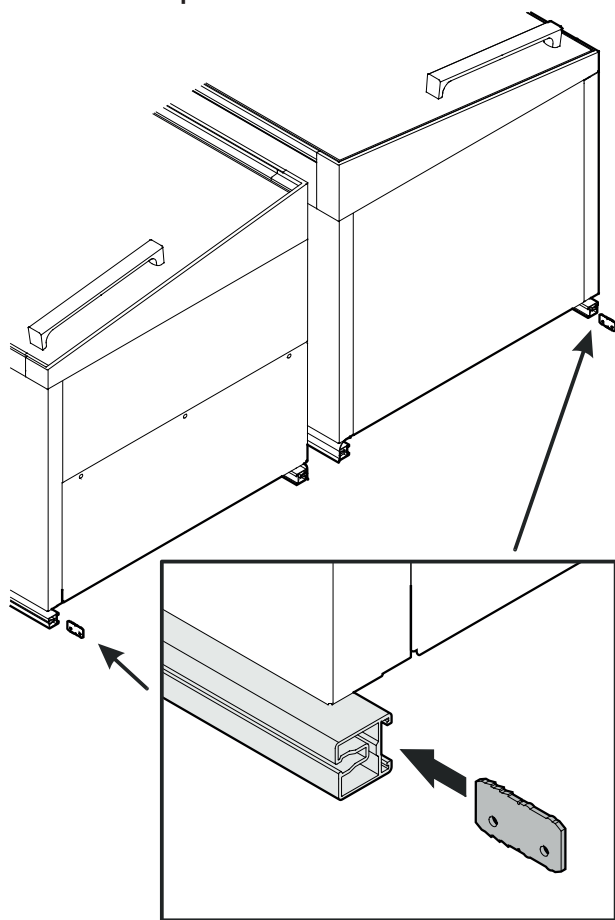

2. Fit profile strips.

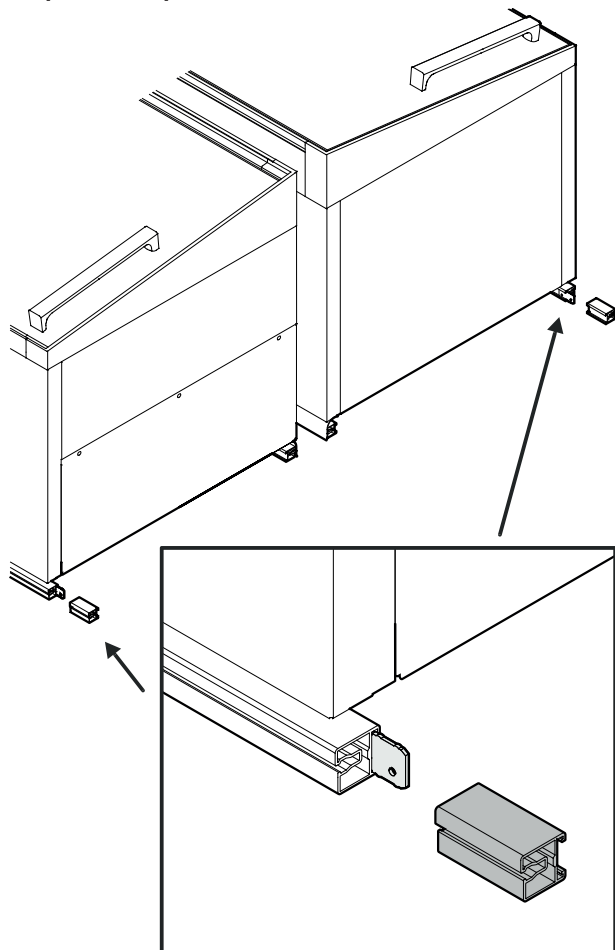

3. Fit brackets.

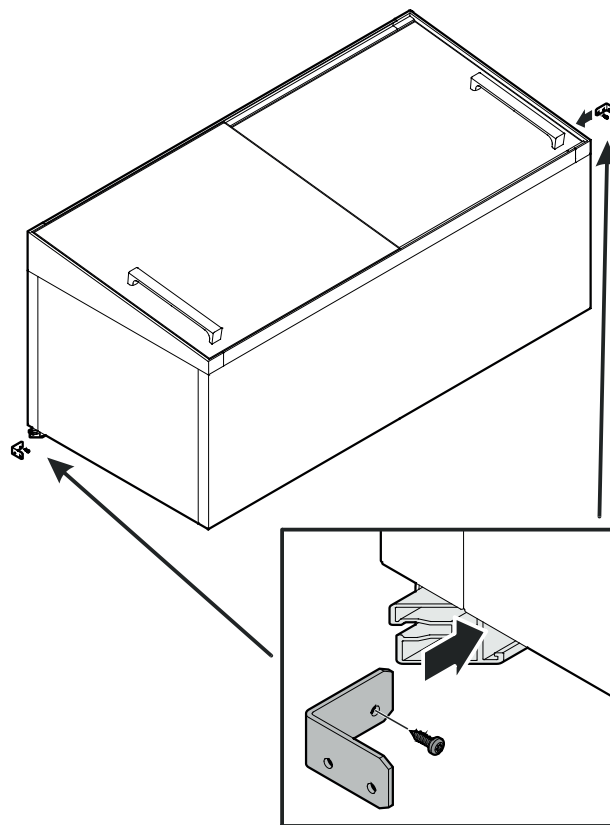

4. Assemble the profile strip for the end-of-aisle chest.

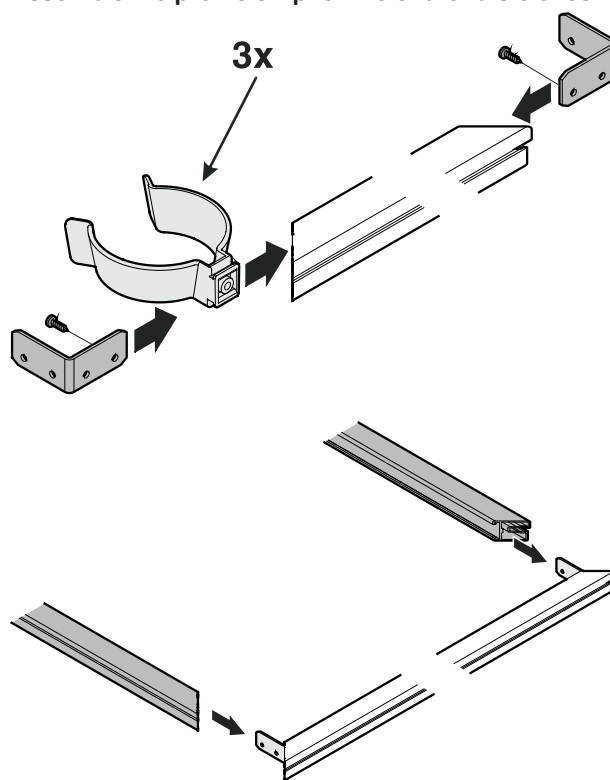

5. Fit profile strips.

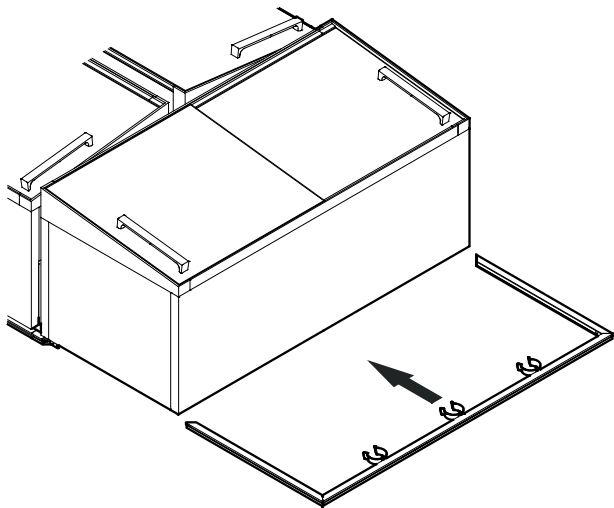

6. Fit protection strips.

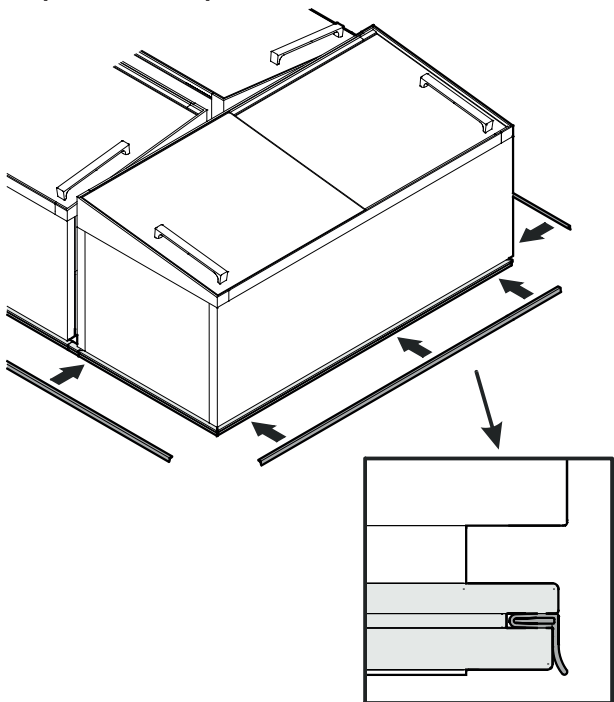

Cover for block configuration

1. Fit retaining elements.

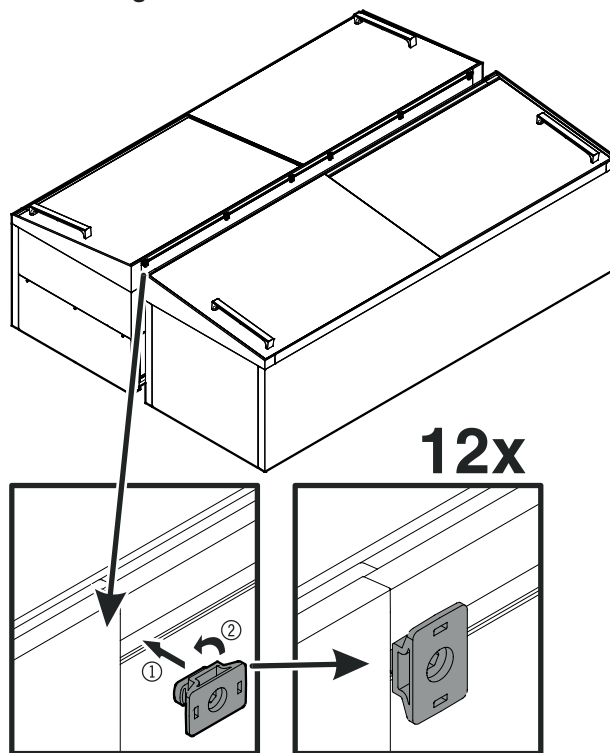

2. Measure distance.
Transfer to cover.
Cut cover to correct length.

A) Configuration without a display unit above the appliances

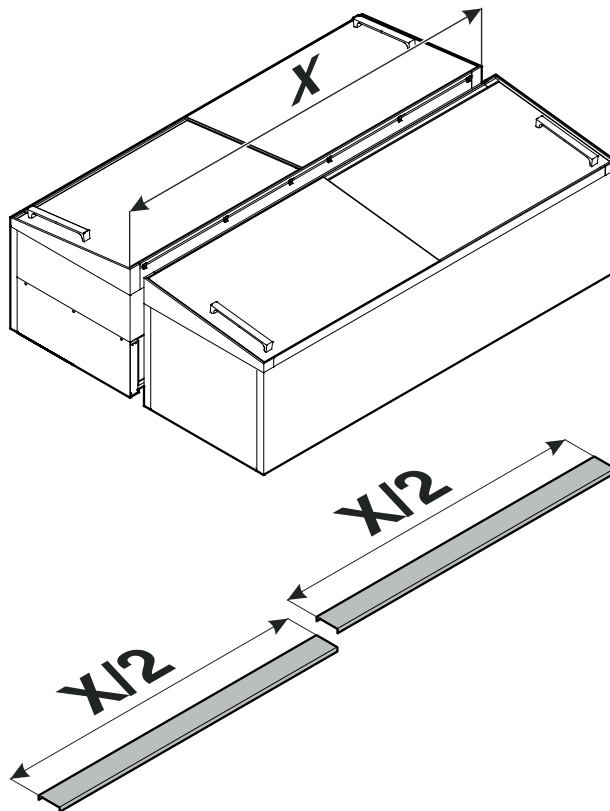

B) Configuration with a display unit above the appliances

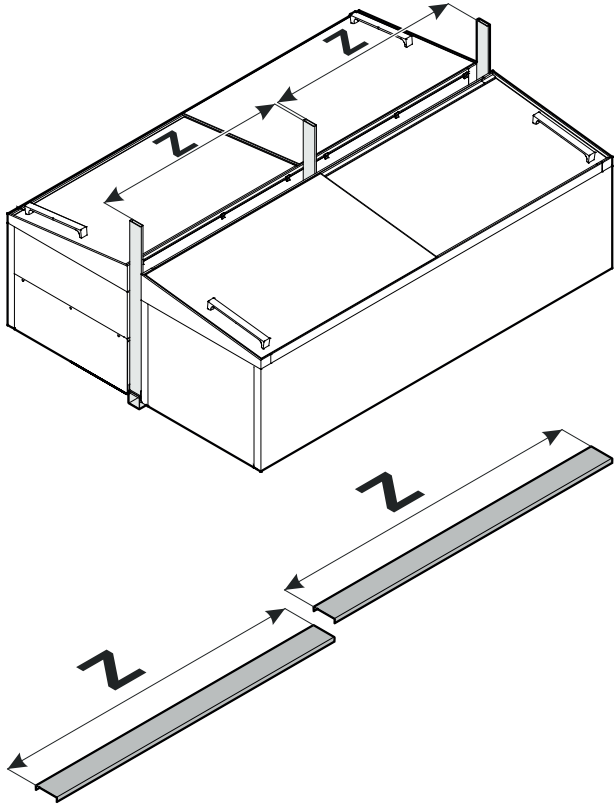

3. Fit the covers.

A) Configuration without a display unit above the appliances

Fit the covers in sequence.

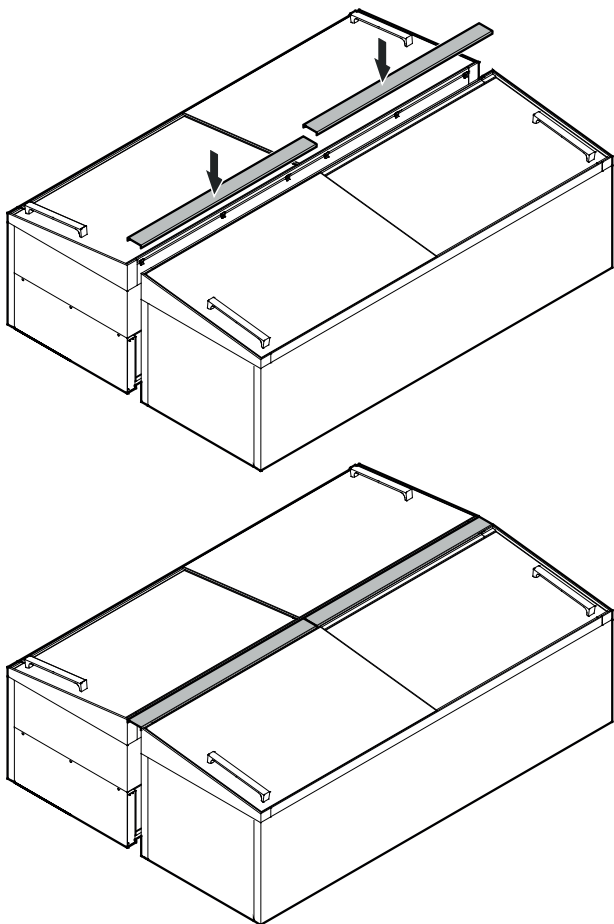

B) Configuration with a display unit above the appliances

Fit the covers in sequence ensuring that the cut-outs match.

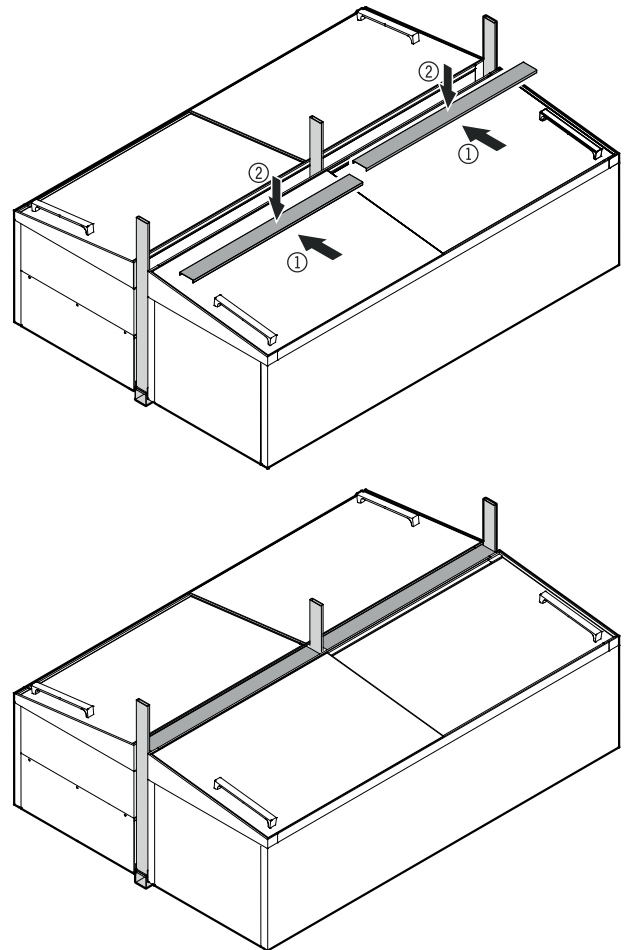

Note

Gaps which may be created at the block ends between the covers and the end-of-aisle appliances or the block end plates can be closed using a cover cut to the appropriate length.

Cover for wall mounting

1. Affix the stickers.

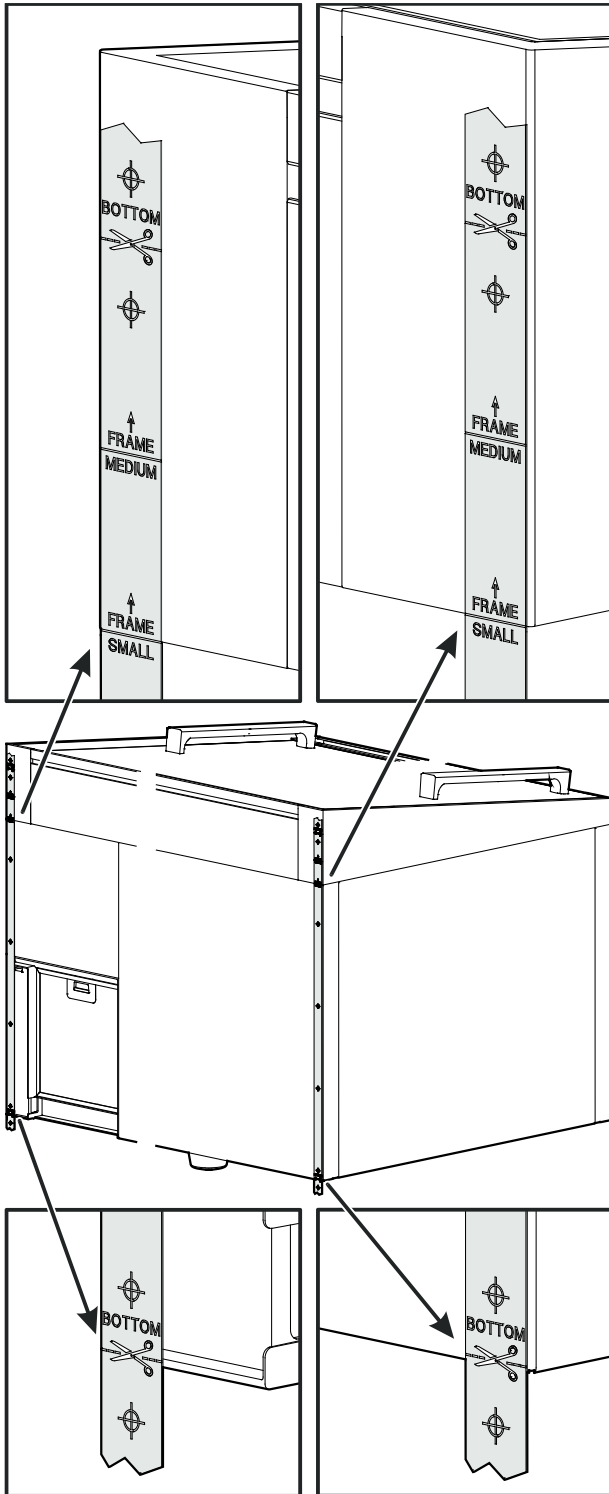

2. Pre-punch holes for the assembly bolts in the stickers using a nail.

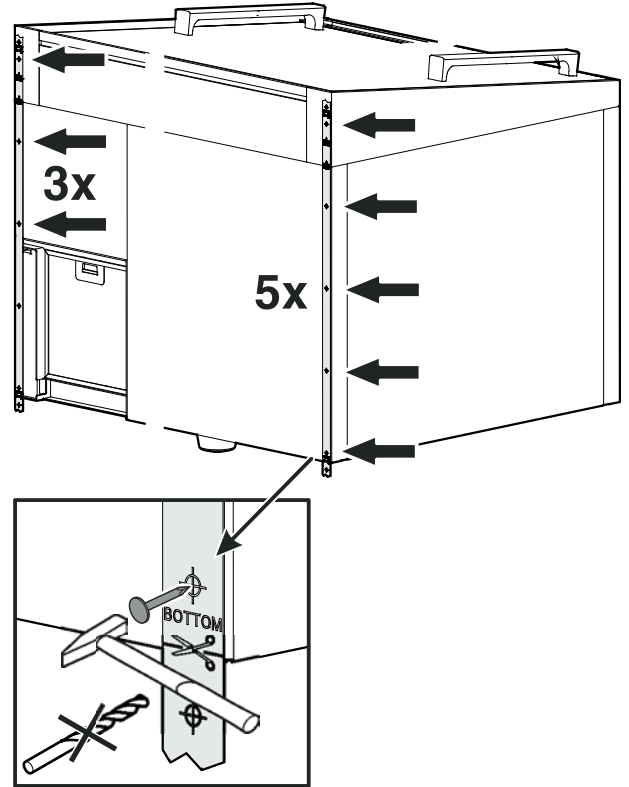

3. Screw the bolts into the appliance.

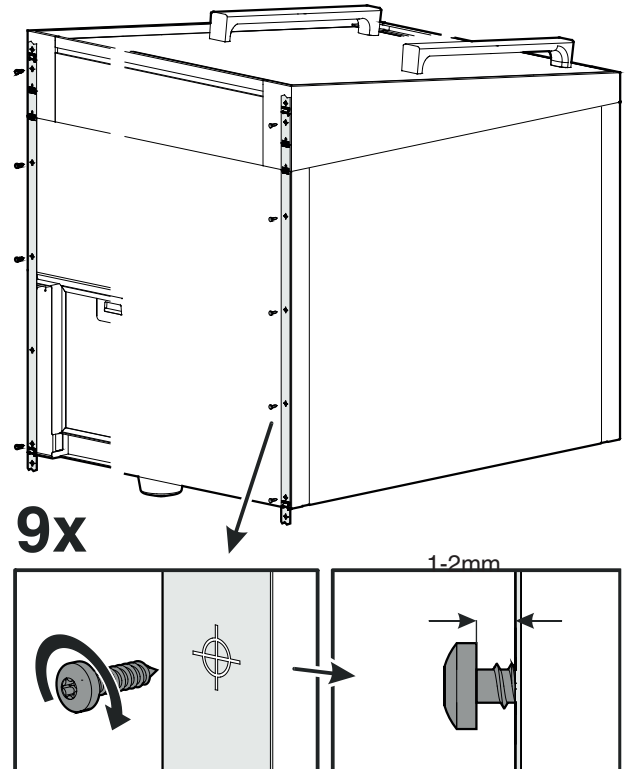

4. Measure distance.
Transfer to cover.
Cut cover to correct length.

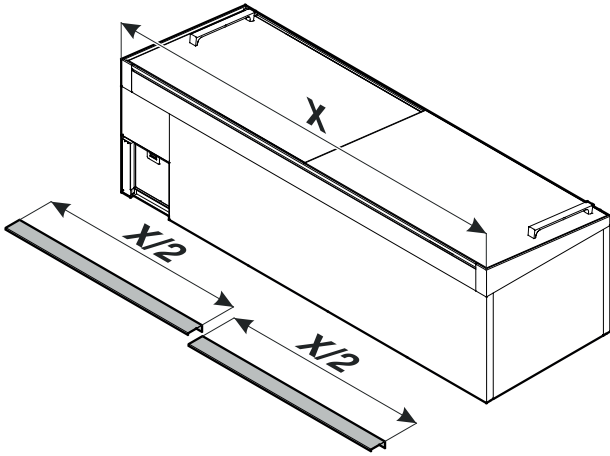

5. Attach the cover plates to the bolts, then press downwards.

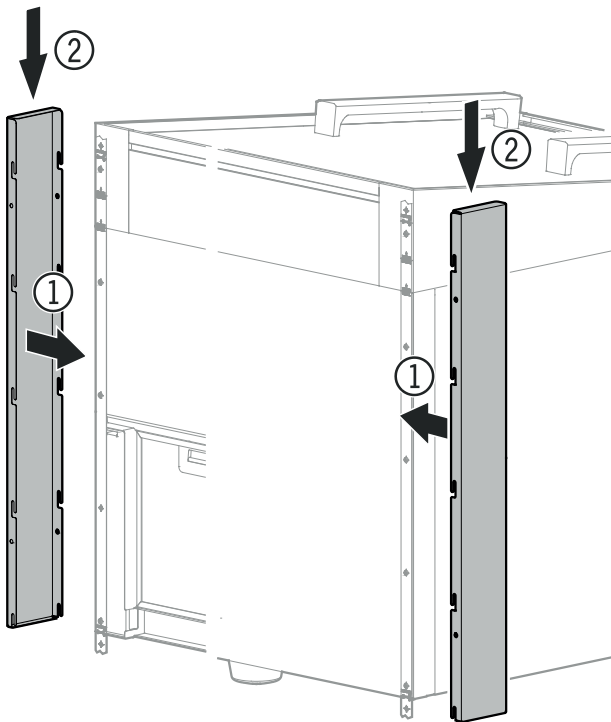

6. Screw on cover.

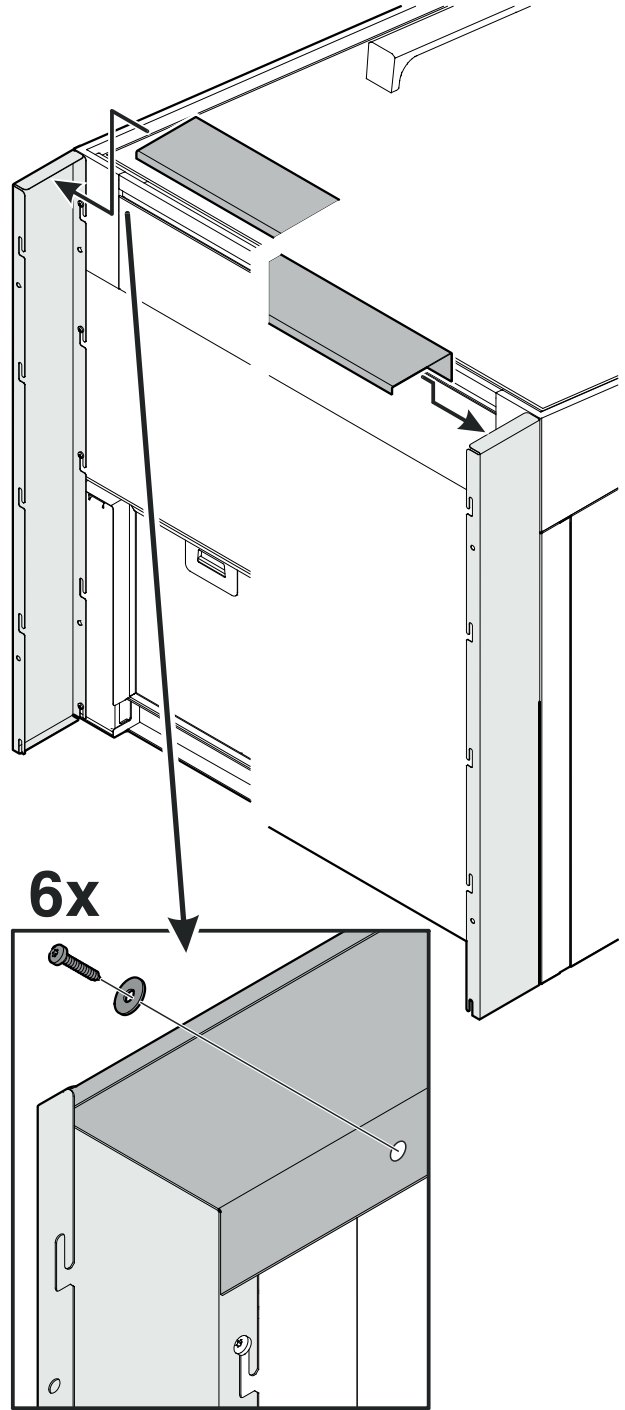

7. Tighten the bolts.

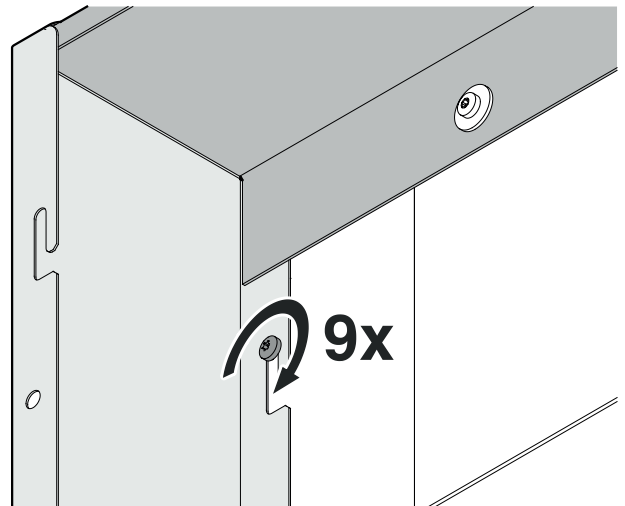

Assigning addresses to the appliances

Enter the address (see "Addressing", page 5) on each appliance individually.

- Touch the activation point on the display with the release key.

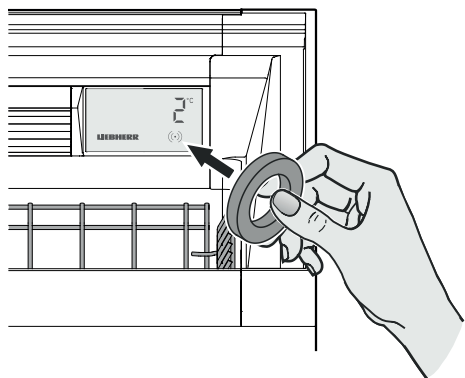

The **control menu** will appear:

- Press **Set** for approx. 5 seconds.

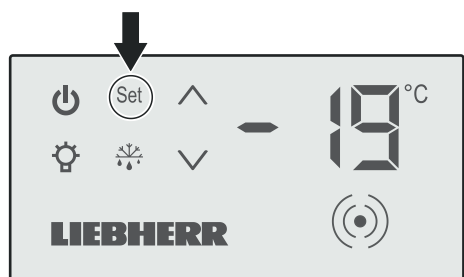

Menu A for entering the address will appear:

- Press **Set** briefly.

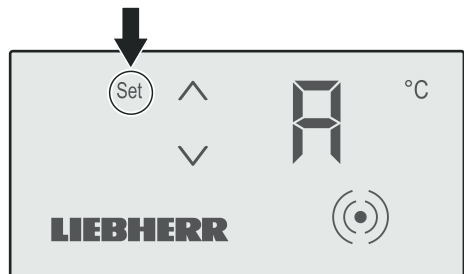

Menu H for entering the hundreds figure will appear; the relevant number will flash:

- Select the required value using $\wedge \vee$.
- Press **Set** briefly to confirm.

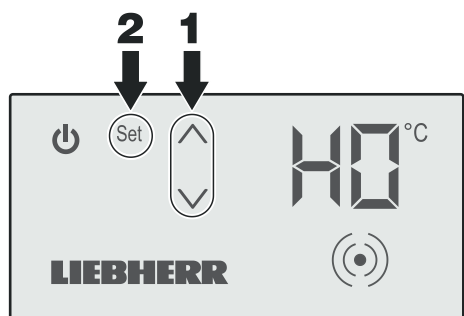

Menu C for entering the tens figure will appear; the relevant number will flash:

- Select the required value using $\wedge \vee$.
- Press **Set** briefly to confirm.

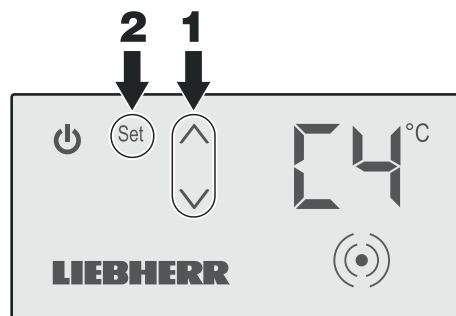

Menu E for entering the units figure will appear; the relevant number will flash:

- Select the required value using $\wedge \vee$.
- Press **Set** briefly to confirm.

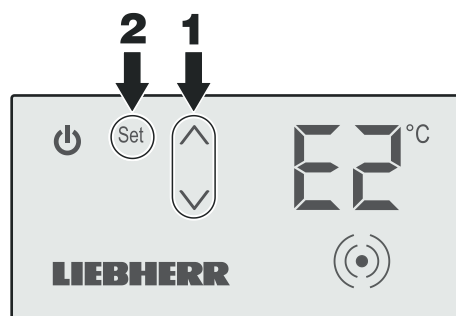

The idle screen will appear:



Note

We recommend that the address of each appliance is noted or documented (e.g. an adhesive label on the rear of the appliance) to speed things up for service work.

Commissioning the appliances

Checks

- Test the lighting connections (if the circuits are separate):
Remove the light fuses – all the appliances must be unlit. If this is not the case, the plugs on the appliances which are lit have been inserted in the wrong sockets, see “Connecting appliances”, page 15.
- Check the appliances for correct functioning and correct temperature setting:
Test the various appliances to ensure that they function perfectly.
If any defects which cannot be rectified are found, please notify our customer service department.
- Check the addresses:
Check the settings of the appliances using the test tool.

Note

Remove the dirt caused by the installation, following the information in the section entitled "Cleaning" in the operating instructions.

This completes the installation work.



See the operating instructions of the relevant appliance for further information about operation.

Fitting various accessories

Fitting product plate holders

Product plate holders for longitudinal appliances, rear

There are two product plates for each appliance. Each product plate must be held by 3 product plate holders to make them more stable.

1. Place 3 holders (angled) into the cover plate as shown and secure them with the wing nuts.

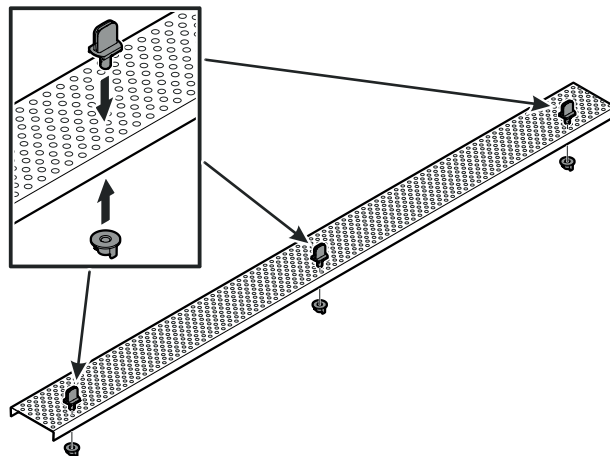

2. Place the product plates in the holders.

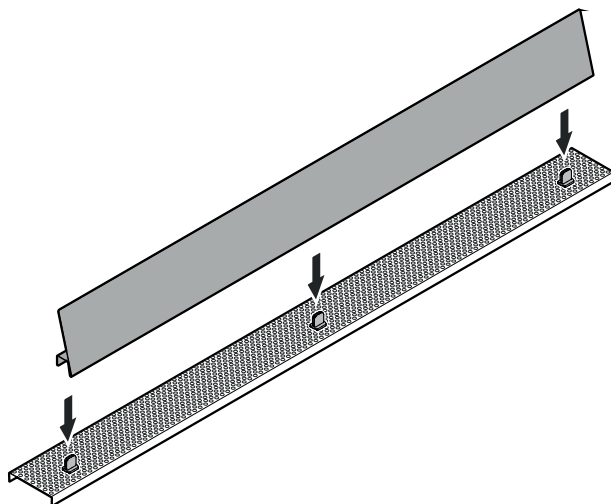

3. Also fit product plate holders on the opposite side if necessary.

4. Insert the covers.

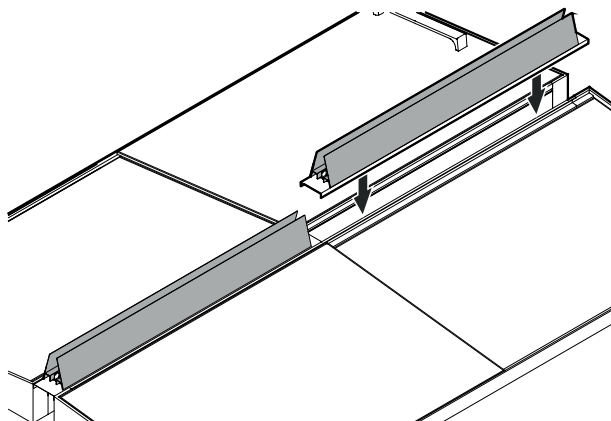

Product plate holders, front

1. Fit cover caps.

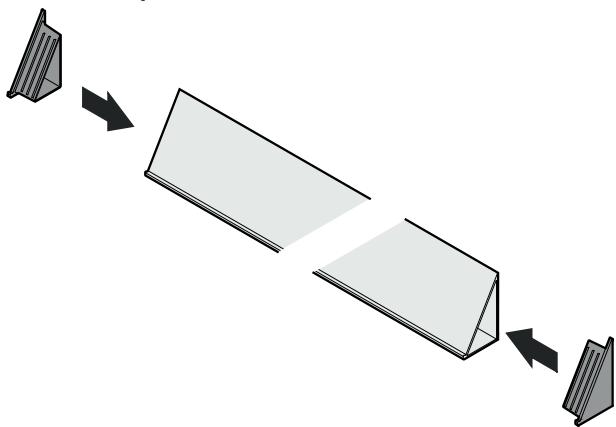

2. Affix product plate holder.

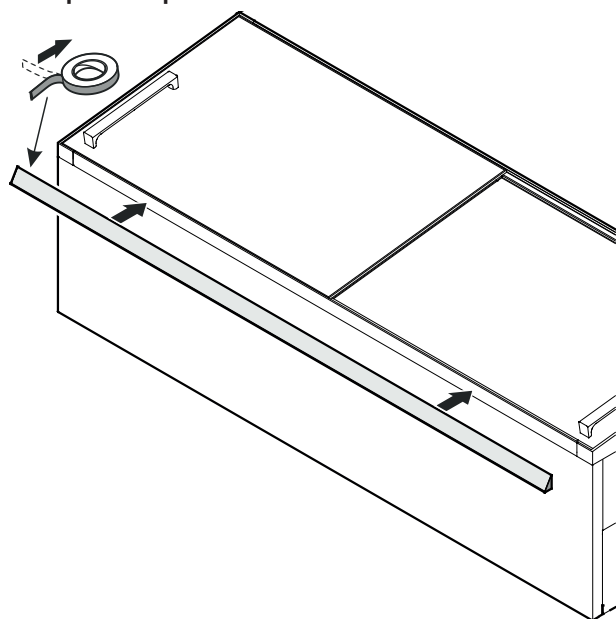

Corner protection

1. Affix corner protection.

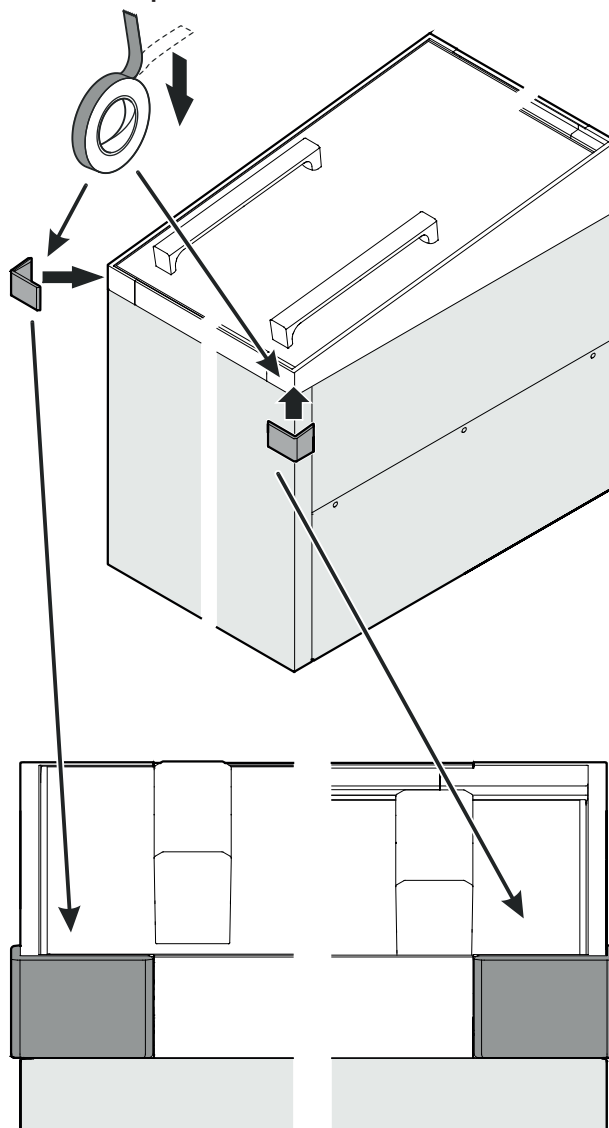

Fitting the collision guard

Dependent on manufacturer

Notice

To insert the anchor bolts in the floor, approval must be obtained from a qualified body to drill holes in the floor. It must be ensured that no cables or pipes (e.g. underfloor heating) in the floor are damaged.

Notice

The air outlet must not be blocked by the collision guard. A **ventilation cross-section of at least 500 cm²** is required in this zone.

Notice

The compressor compartment must be accessible at all times. Therefore, it is recommended to keep the lateral collision guard as short as possible or to choose a modular set-up. Avoid having to remove the entire collision guard from the end-of-aisle chest before the compressor compartment can be opened.

Collision guard for longitudinal chests

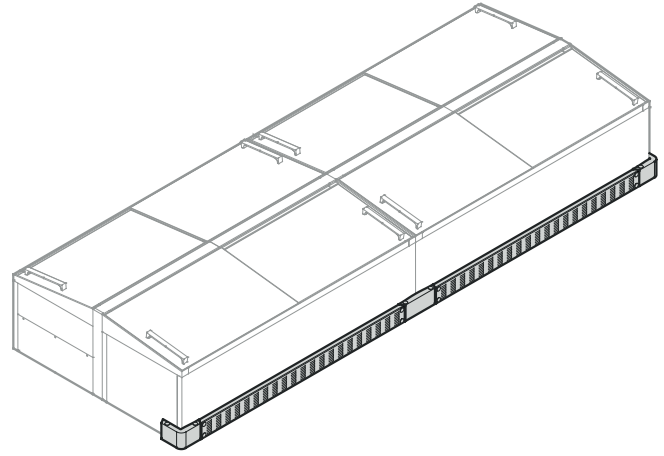

Block completion with end-of-aisle appliance

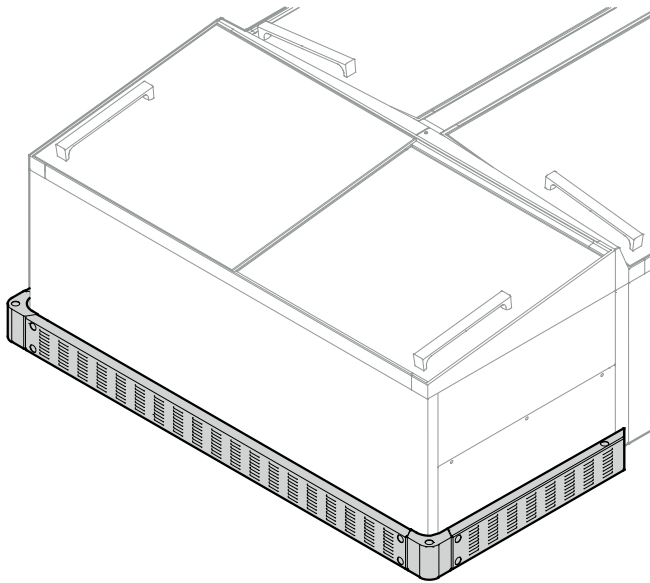

Block completion with cover plate

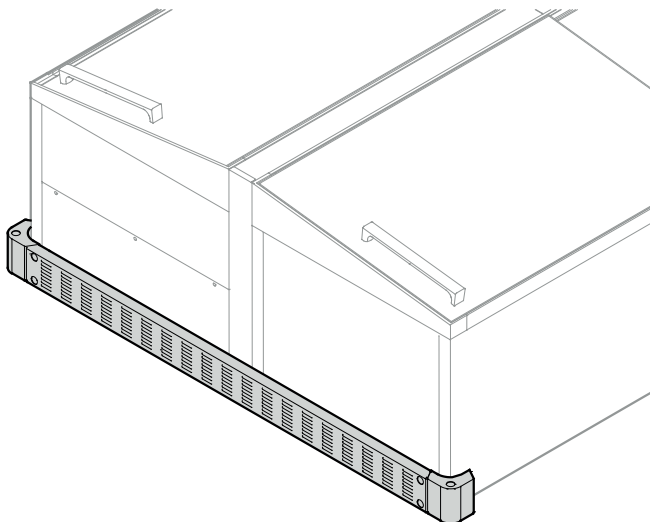

Technical data

Appliance type: SMALL

End-of-aisle appliance		
1.8 m		
	Freezing	Switch-over
Operating mode	Freezing	Switch-over
Description	SGTEs 772	STEs 772 / 752
Overall electrical data (including LED lighting)		
Rated voltage	220-240 V	220-240 V
Frequency	50 / 60Hz	50 / 60Hz
Rated current	4.5 A	4.5 A
Compressor system inverter (frequency converter)	Yes	Yes
Fuse on each appliance	RCBO 10 to 16 A Characteristic B, C	RCBO 10 to 16 A Characteristic B, C
Length of mains cable	2.50 m	2.50 m
Interface (standard)	CAN bus	CAN bus
Interface (alternative)	MODBUS	MODBUS
Electrical data for LED lighting		
Power consumption of rear lighting	14 W	14 W
Power consumption of front lighting	14 W	14 W

Technical data

Appliance type: MEDIUM

End-of-aisle appliance		
1.8 m		
	Freezing	Switch-over
Operating mode	Freezing	Switch-over
Description	SGTEm 872	STEm 872 / 852
Overall electrical data (including LED lighting)		
Rated voltage	220-240 V	220-240 V
Frequency	50 / 60Hz	50 / 60Hz
Rated current	4.5 A	4.5 A
Compressor system inverter (frequency converter)	Yes	Yes
Fuse on each appliance	RCBO 10 to 16 A Characteristic B, C	RCBO 10 to 16 A Characteristic B, C
Length of mains cable	2.50 m	2.50 m
Interface (standard)	CAN bus	CAN bus
Interface (alternative)	MODBUS	MODBUS
Electrical data for LED lighting		
Power consumption of rear lighting	14 W	14 W
Power consumption of front lighting	14 W	14 W

Technical data
Appliance type: SMALL

	Longitudinal appliance			
	2.10 m		2.50 m	
	Freezing	Switch-over	Freezing	Switch-over
Operating mode				
Description	SGTs 872 / 852	STs 872 / 852	SGTs 1072 / 1052	STs 1072 / 1052
Overall electrical data (including LED lighting)				
Rated voltage	220-240 V	220-240 V	220-240 V	220-240 V
Frequency	50 / 60Hz	50 / 60Hz	50 / 60Hz	50 / 60Hz
Rated current	4.5 A	4.5 A	4.5 A	4.5 A
Compressor system inverter (frequency converter)	Yes	Yes	Yes	Yes
Fuse on each appliance	RCBO 10 to 16 A Characteristic B, C	RCBO 10 to 16 A Characteristic B, C	RCBO 10 to 16 A Characteristic B, C	RCBO 10 to 16 A Characteristic B, C
Length of mains cable	2.50 m	2.50 m	2.50 m	2.50 m
Interface (standard)	CAN bus	CAN bus	CAN bus	CAN bus
Interface (alternative)	MODBUS	MODBUS	MODBUS	MODBUS
Electrical data for LED lighting				
Power consumption of rear lighting	17 W	17 W	21 W	21 W
Power consumption of front lighting	17 W	17 W	21 W	21 W

Technical data
Appliance type: MEDIUM

	Longitudinal appliance			
	2.10 m		2.50 m	
	Freezing	Switch-over	Freezing	Switch-over
Operating mode				
Description	SGTm 972 / 952	STm 972 / 952	SGTm 1172 / 1152	STm 1172 / 1152
Overall electrical data (including LED lighting)				
Rated voltage	220-240 V	220-240 V	220-240 V	220-240 V
Frequency	50 / 60Hz	50 / 60Hz	50 / 60Hz	50 / 60Hz
Rated current	4.5 A	4.5 A	4.5 A	4.5 A
Compressor system inverter (frequency converter)	Yes	Yes	Yes	Yes
Fuse on each appliance	RCBO 10 to 16 A Characteristic B, C	RCBO 10 to 16 A Characteristic B, C	RCBO 10 to 16 A Characteristic B, C	RCBO 10 to 16 A Characteristic B, C
Length of mains cable	2.50 m	2.50 m	2.50 m	2.50 m
Interface (standard)	CAN bus	CAN bus	CAN bus	CAN bus
Interface (alternative)	MODBUS	MODBUS	MODBUS	MODBUS
Electrical data for LED lighting				
Power consumption of rear lighting	17 W	17 W	21 W	21 W
Power consumption of front lighting	17 W	17 W	21 W	21 W



Liebherr Hausgeräte Lienz GmbH

Dr.-Hans-Liebherr-Strasse 1

A-9900 Lienz

Österreich

www.liebherr.com

