

# SCR Parts Kit Manual

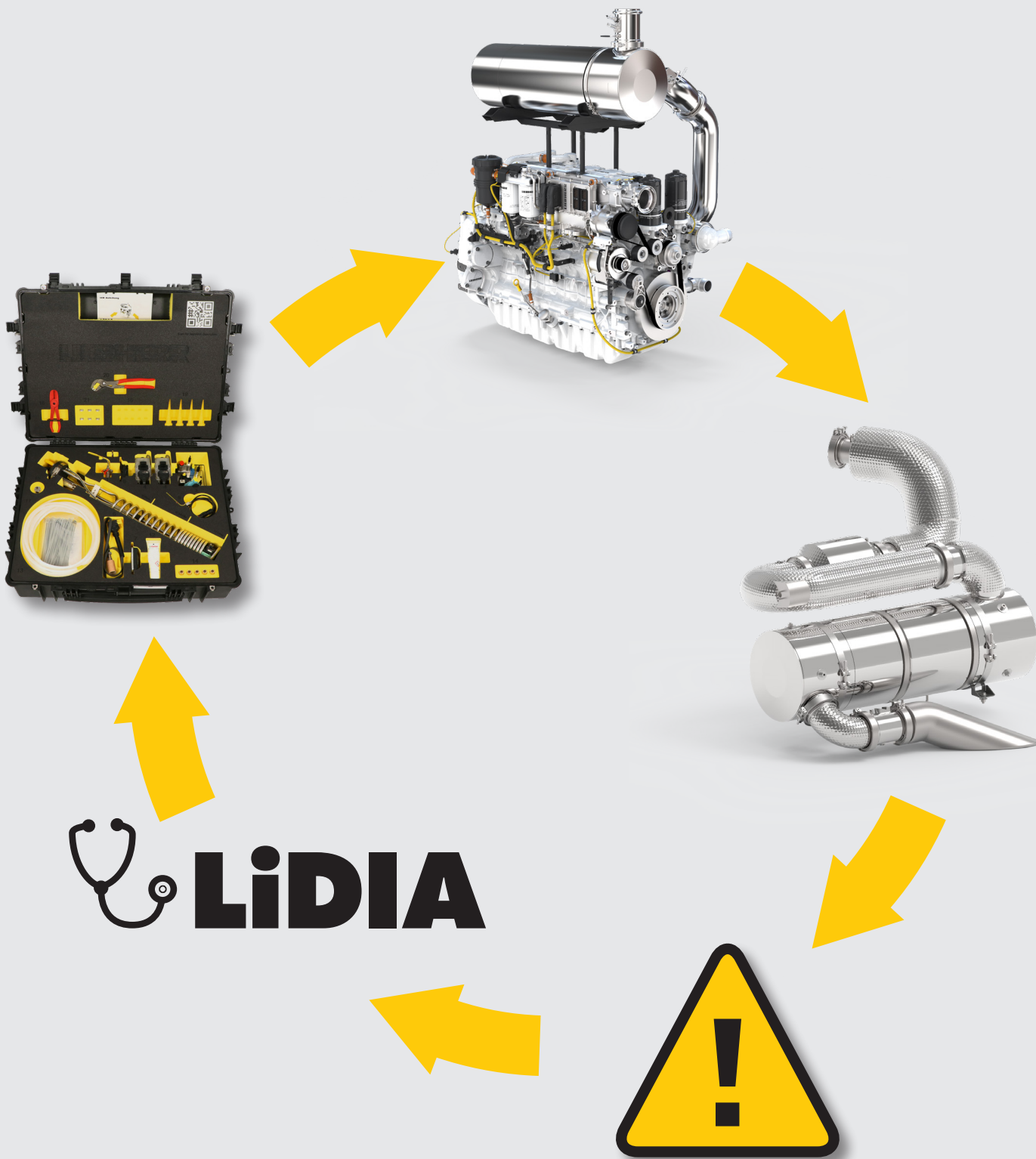

 **LiDIA**

# Document ID

**Author:** LWN / Technical Documentation Department  
**Version:** V01.01  
**Issued:** 20201015

## Manufacturer

Liebherr-Werk Nenzing GmbH  
Dr. Hans Liebherr Straße 1  
6710 Nenzing  
Austria  
+43 50809 41-0  
info.lwn@liebherr.com

# Notes regarding the documentation

## Display conventions

### Illustrations

The illustrations in this document serve to convey information and principles and are usually simplified or schematic representations which do not depict the current machine equipment.

### Numerical values and units

The machine is constructed in accordance with the metric system of units. The numerical values used in the imperial system of units were converted and rounded.



### Symbols

Symbol	Meaning
*	Optional additional equipment
□	Requirement must be met
▶	Performing an action
▷	Consequence of an action

*Symbols*

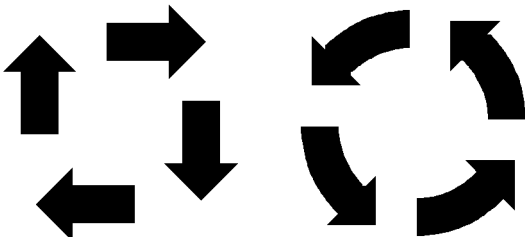
### Symbols in illustrations

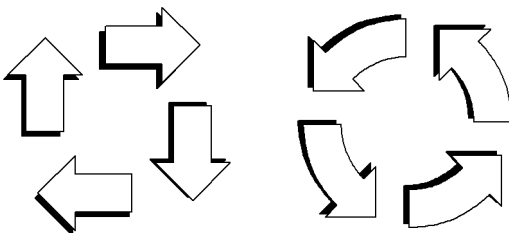
Symbol	Meaning
	Actions
<b>1 2 3 4 5 6 7 8 9 10</b>	Mandatory sequence of several actions in an illustration
<b>A B C D E</b>	Arbitrary sequence of several actions in an illustration

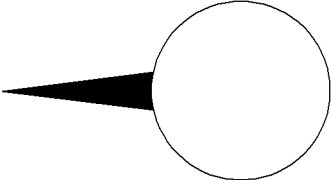
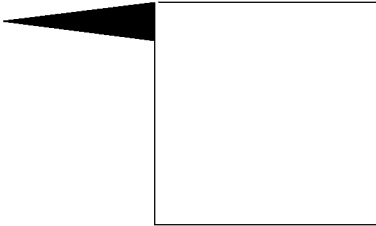
Symbol	Meaning
	Consequences of actions
	Consequences of actions with mandatory sequence
	Consequences of actions with arbitrary sequence
	Enlargement of a section or component in the same perspective as in the illustration
	Enlargement of a section or component in a different perspective than in the illustration

Symbols in illustrations

### Marking of warning messages

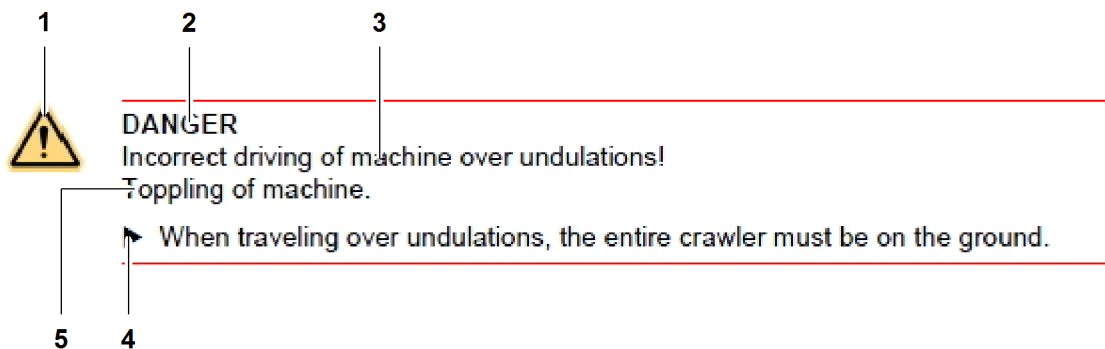

Name	Description	
1	Warning signs	Warns of possible risk of injury
2	Signal word	For further information see: signal words
3	Source of danger	Explanation of the danger (context)
4	Measures	Measures to prevent the danger

Name		Description
5	Consequences of the danger	Consequences of non-observance and possible further information required for understanding

*Marking of warning messages*

## Signal words



### **DANGER**

Denotes an immediate dangerous situation which will result in death or serious injuries if it is not avoided.

▶ Refers to the current action to reduce or avoid danger(s).



### **WARNING**

Denotes a dangerous situation which could result in death or serious injuries if it is not avoided.

▶ Refers to the current action to reduce or avoid danger(s).



### **CAUTION**

Denotes a dangerous situation which could result in minor or moderate physical injuries if it is not avoided.

▶ Refers to the current action to reduce or avoid danger(s).

### **NOTICE**

Denotes a dangerous situation which could result in material damage if it is not avoided.

▶ Refers to the current action to reduce or avoid danger(s).

## Additional markings



### **Note**

Denotes useful notes and hints.

▶ Refers to the current action and demonstrates how to perform actions in an easier way.



# Contents

<b>1</b>	<b>Product description</b>	<b>11</b>
1.1	General	11
1.2	Warning levels	12
1.3	Overview exhaust system exhaust stage IV (Tier 4f)	14
1.4	Overview exhaust system exhaust stage V	17
1.5	Contents of spare parts case for SCR system	20
1.6	Article list spare parts case for SCR system	22
1.7	Tool list (not included)	25
<b>2</b>	<b>Repair</b>	<b>29</b>
2.1	Preparing for repair	29
2.1.1	Repair process	29
2.1.2	Preconditions	29
2.1.3	Performing diagnosis	30
2.2	Performing repair	32
2.2.1	Injector with sealing	32
2.2.2	Urea pump	34
2.2.3	NOx sensor	37
2.2.4	Temperature sensor	39
2.2.5	NH3 control unit with NH3 sensor	41
2.2.6	Differential pressure sensor	43
2.2.7	Suction module	45
2.2.8	Air line	48
<b>3</b>	<b>Overview of suction modules</b>	<b>55</b>
3.1	Construction machinery (LR, HS and FE)	55
3.1.1	Short suction module (Pos. 9, Ident. no. 12503114)	55
3.1.2	Medium suction module (Pos. 10, Ident. no. 12503117)	56
3.1.3	Long suction module (Pos.11, Ident. no. 12503120)	56
3.2	Maritime machines	57

---

3.2.1	Short suction module (Pos. 9, Ident. no. 12503114)	57
3.2.2	Medium suction module (Pos. 10, Ident. no. 12503117)	57
3.2.3	Long suction module (Pos.11, Ident. no. 12503120)	57
<b>4</b>	<b>Part list</b>	<b>61</b>
4.1	Part list spare parts case for SCR system	61
4.2	Part list optionally available tools	62

---





---

# 1 Product description

---

# 1 Product description





## 1.1 General

When a machine reports an SCR error, the error must be rectified within **200 operating minutes**.

Independent repair is possible with the help of the spare parts case for SCR System and LiDIA Light.

The spare parts case for SCR system ensures continued operation at full power.

## 1.2 Warning levels

Display				
Warning levels	Warning level 1	Warning level 2	Warning level 3	Warning level 4
Output	DEF light	maximum 75% Nm	maximum 20% Nm	final reduction
Time	0 to 60 min	60 to 170 min	170 to 200 min	< 200 min
High Level error Code				
P1187	SCR error			
	DEF-Level < 10 %			
P1188		SCR error		
		DEF-Level < 5 %		
P1189			SCR error	
			DEF-Level < 2.5 %	
P1190				SCR error
				DEF-Level < 0.1 %

Tab. 1: Warning levels

### Warning level 1

The following information is displayed:

- Machine operator information: error symbol appears on machine operator display.
- Error code: P1187
- Power: no power reduction
- Time: 0 to 60 Minuten

### Warning level 2

The following information is displayed:

- Machine operator information: error symbol appears on machine operator display.
- Error code: P1188
- Power: slight power reduction, maximum torque 75%.
- Time: 60 to 170 Minuten

### Warning level 3

The following information is displayed:

- Machine operator information: error symbol appears on machine operator display.
- Error code: P1189
- Power: heavy power reduction from 75% torque to maximum 20% torque and maximum 60% nominal speed.
- Time: 170 to 200 Minuten

#### **Warning level 4**

The following information is displayed:

- Machine operator information: error symbol appears on machine operator display.
- Error code: P1190
- Power: heavy power reduction from 75% torque to maximum 20% torque and maximum 60% nominal speed.
- Time: from 200 Minuten
- One-time repair by customer is possible. If unsuccessful, the error can only be reset by Liebherr technician.

# 1.3 Overview exhaust system exhaust stage IV (Tier 4f)

## Distinguishing feature

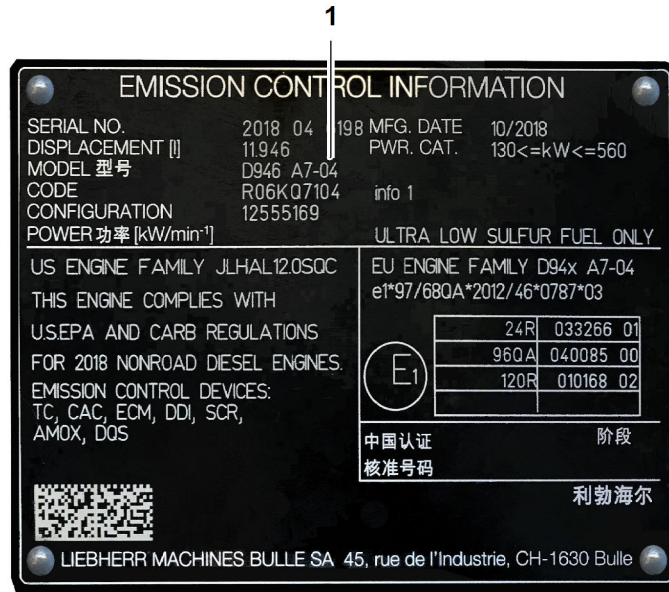

Fig. 8: Diesel engine type plate exhaust stage IV (Tier 4f)

### 1 Distinguishing feature

The exhaust stage can be found on diesel engine type plate on the distinguishing feature 1.

Liebherr does not use a DOC (catalytic converter) with exhaust stage IV. Instead, a thermal management ensures correct exhaust gas temperatures and a higher NO<sub>2</sub> content in the exhaust gas. To prevent forming of unwanted odors, a CUC (ammonia trap catalytic converter) is installed downstream which converts the excessive ammonia back to nitrogen oxides.

## Diagram exhaust stage IV (Tier 4f)

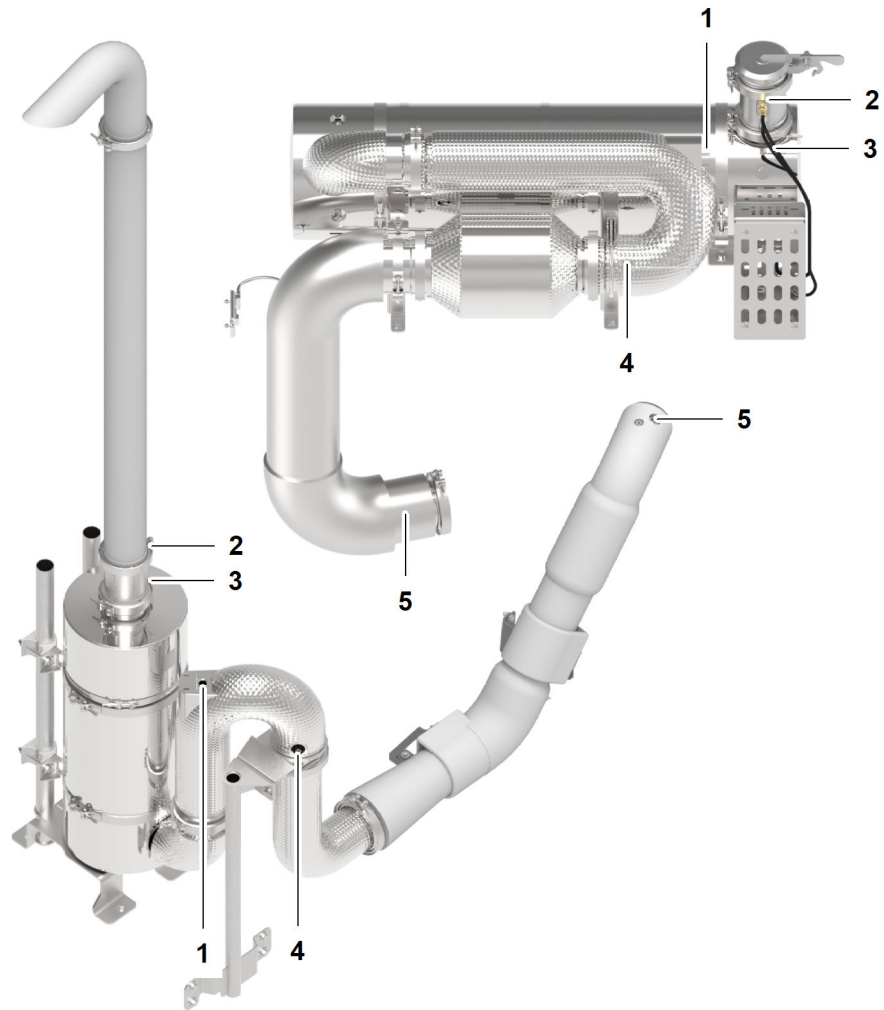

Fig. 9: Diagram exhaust system exhaust stage IV (Tier 4f)

- |          |                              |          |                            |
|----------|------------------------------|----------|----------------------------|
| <b>1</b> | Injector                     | <b>5</b> | NOx sensor <i>UPstream</i> |
| <b>2</b> | NH3 sensor and control unit  | <b>6</b> | Suction module             |
| <b>3</b> | NOx sensor <i>DOWNstream</i> | <b>7</b> | Urea pump                  |
| <b>4</b> | Temperature sensor           |          |                            |

The injector **1** atomizes the air-urea mixture.

The NH3 sensor **2** measures the ammonia content after the exhaust aftertreatment and enables the correction of DEF dosing.

NOx sensor **3** and NOx sensor **5** detect the lambda and NOx values before and after the exhaust aftertreatment and warn if the NOx value is too high.

The temperature sensors **4** measure the temperature in the exhaust system branch and warn if the temperature is too high.

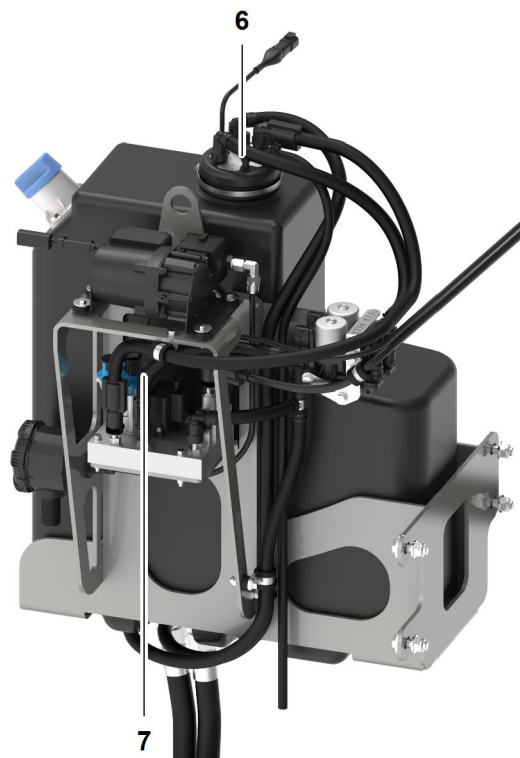

Fig. 10: Diagram exhaust system exhaust stage IV (Tier 4f)

6 Suction module

7 Urea pump

The suction module **6** is equipped with an optical sensor. The suction module **6** has its own control unit. The following information is transmitted to electronic control unit (ECU) via CAN bus:

- DEF temperature
- DEF fill level
- DEF quality

Urea pump **7** (also called dosing unit) consists of the following components:

- DEF pump
- Switchover valve
- Pressure sensor for air and urea

The urea pump **7** is supplied with cooling water to prevent the urea from freezing.

**Exhaust stage IV is used with the following engine types:**

Engine type	Engine type
D944 A7-04	4 cylinder, in-line engine
D936 A7-04	6 cylinder, in-line engine
D946 A7-04	6 cylinder, in-line engine
D9508 A7-04	8 cylinder, v-engine
D9512 A7-04	12 cylinder, v-engine

Tab. 2: Area of application exhaust system exhaust stage IV (Tier 4f)



## 1.4 Overview exhaust system exhaust stage V

### Distinguishing feature exhaust stage V

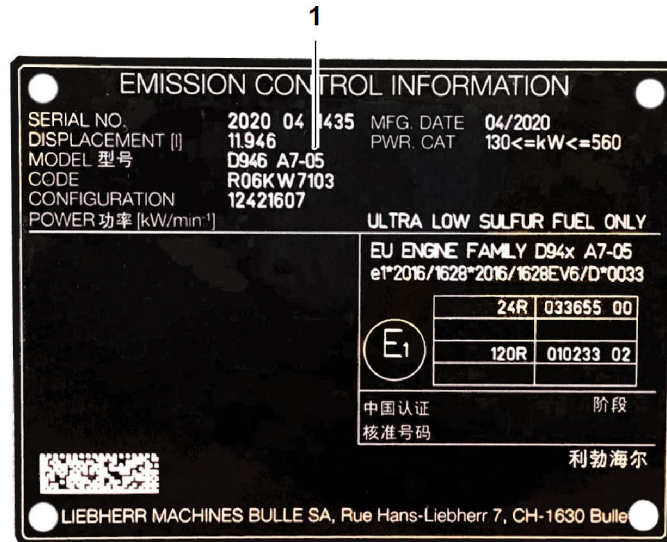

Fig. 11: Diesel engine type plate exhaust stage V

#### 1 Distinguishing feature

The exhaust stage can be found on diesel engine type plate on the distinguishing feature 1.

Liebherr uses a DOC (catalytic converter) with exhaust stage V. The DOC ensures a longer service life of the SCR filter module by burning of unburned fuel at temperatures over 260 °C.

The additional SCR filter module improves the emission values again. The DOC helps with adjusting the ratio of NO to NO<sub>2</sub>. This leads to a higher NO<sub>x</sub> conversion rate in later reactions in the SCR catalytic converter. For the SCR system to function properly, all components must function flawlessly.

## Diagram exhaust stage V

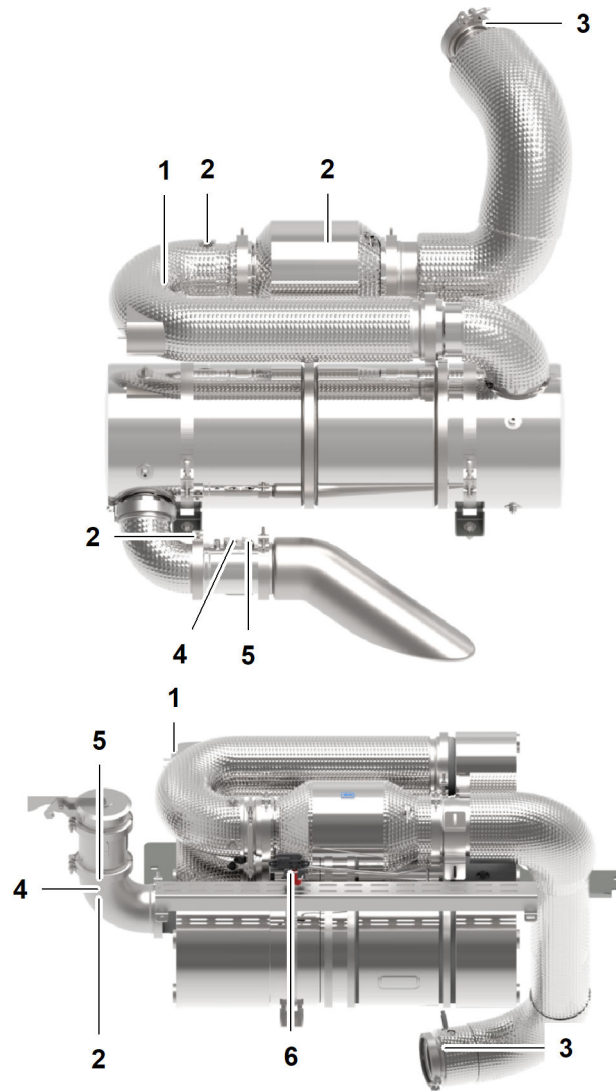

Fig. 12: Diagram exhaust system exhaust stage V

1	Injector	4	NOx sensor <i>DOWNstream</i>
2	Temperature sensor	5	NH3-sensor with control unit
3	NOx sensor <i>UPstream</i>	6	Differential pressure transducer

The injector 1 atomizes the air-urea mixture.

The temperature sensors 2 measure the temperature in the exhaust system branch. The temperature sensors 2 issue a warning if the temperature is too high.

NOx sensor *UPstream* 3 and NOx sensor *DOWNstream* 4 detect the lambda and NOx values before and after the exhaust aftertreatment and warn if the NOx content is too high.

The NH3 sensor 5 measures the ammonia content after the exhaust aftertreatment and enables the correction of DEF dosing.

The differential pressure transducer 6 is used for calculating soot deposits. The quality of the SCR filter module is checked through measuring the differential pressure.

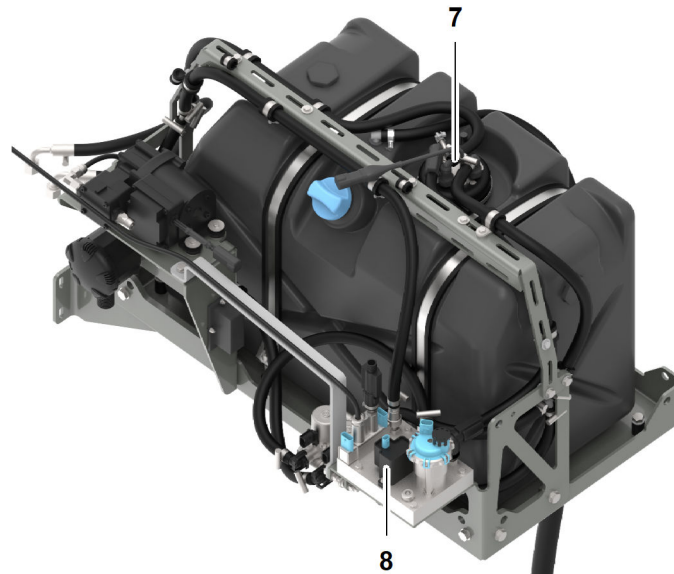

Fig. 13: Diagram exhaust system exhaust stage V

**7** Suction module

**8** Urea pump

The suction module **7** is equipped with an optical sensor. The suction module **7** has its own control unit. The following information is transmitted to electronic control unit (ECU) via CAN bus:

- DEF temperature
- DEF fill level
- DEF quality

The urea pump **8** suctions the urea out of the urea tank via the suction module **7** urea tank. Thus, the urea pump **8** supplies the SCR system with urea.

**Exhaust stage V is used with the following engine types:**

Engine type	Engine type
D944 A7-05	4 cylinder, in-line engine
D936 A7-05	6 cylinder, in-line engine
D946 A7-05	6 cylinder, in-line engine
D976 A7-05	6 cylinder, in-line engine
D9508 A7-04 (Stage V)	8 cylinder, v-engine
D9512 A7-04 (Stage V)	12 cylinder, v-engine

Tab. 3: Area of application exhaust system exhaust stage V

## 1.5 Contents of spare parts case for SCR system

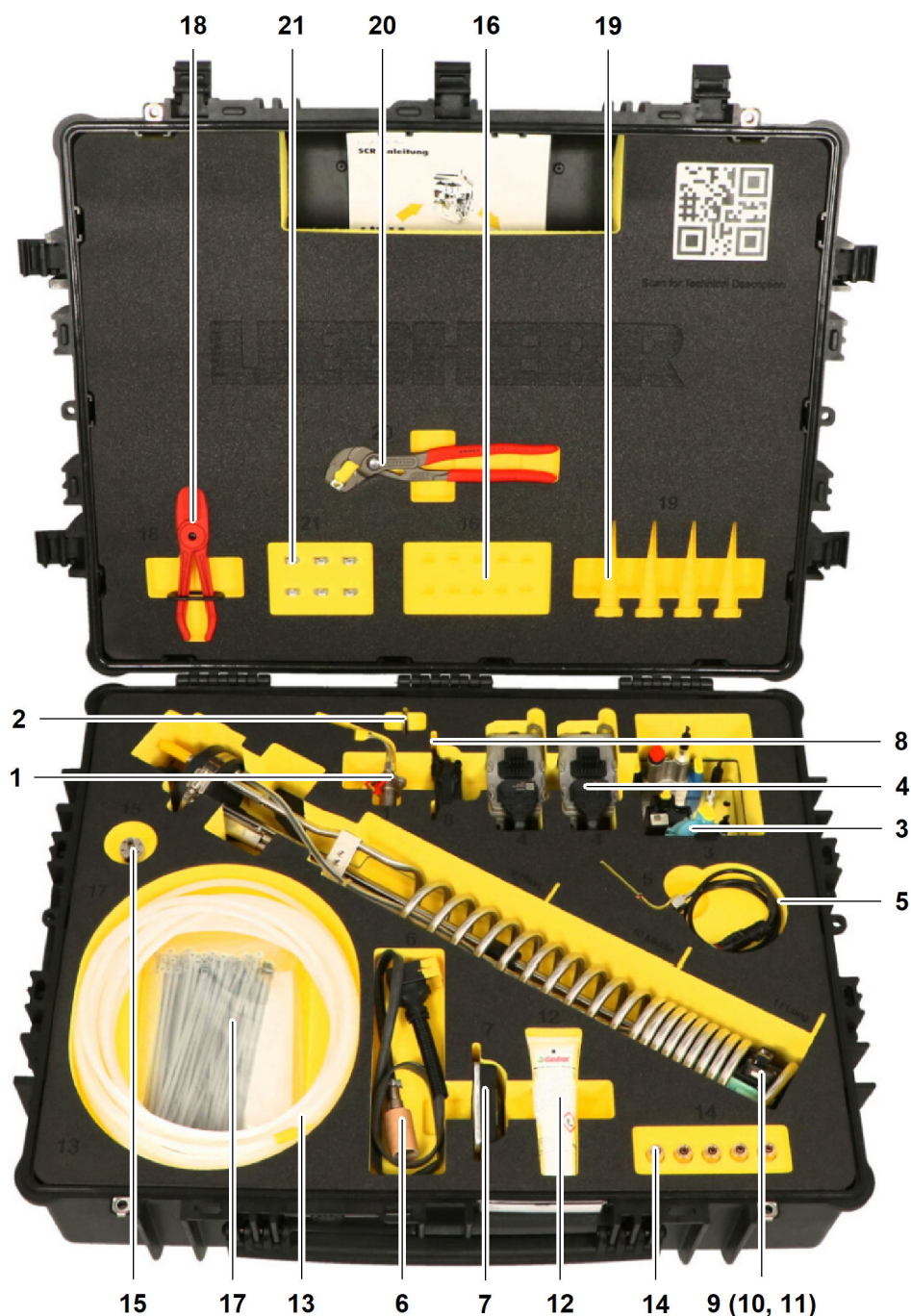

Fig. 14: Contents of spare parts case for SCR system

- |   |                      |    |                                  |
|---|----------------------|----|----------------------------------|
| 1 | Injector             | 12 | Castrol paste                    |
| 2 | Sealing for injector | 13 | Air line                         |
| 3 | Urea pump            | 14 | Wira- coupling (5x)              |
| 4 | NOx sensor (2x)      | 15 | Air Hose Removal Tool            |
| 5 | Temperature sensor   | 16 | Servicing cap (10x)              |
| 6 | SCR NH3 sensor       | 17 | Cable ties heat resistant (100x) |

*See next page for continuation of the image legend*

<b>7</b>	NH3 control unit	<b>18</b>	Clamp
<b>8</b>	Differential pressure sensor	<b>19</b>	Service plug Classic (4x)
<b>9</b>	Short suction module	<b>20</b>	Hose clamp pliers
<b>10</b>	Medium suction module	<b>21</b>	Hose clamp (6x)
<b>11</b>	Long suction module		

## 1.6 Article list spare parts case for SCR system

The spare parts case for SCR system consists of the following components:

Item	Name	Ident. no.	Exhaust system
1	 <p>Injector (For more information see: 2.2.1 Injector with sealing, page 32.)</p>	10144093	Stage IV / V (Tier 4f)
2	 <p>Sealing (For more information see: 2.2.1 Injector with sealing, page 32.)</p>	10144861	Stage IV / V (Tier 4f)
3	 <p>Urea pump (For more information see: 2.2.2 Urea pump, page 34.)</p>	11373478	Stage IV / V (Tier 4f)
4	 <p>NOx sensor (For more information see: 2.2.3 NOx sensor, page 37.)</p>	12412141	Stage IV / V (Tier 4f)
5	 <p>Temperature sensor (For more information see: 2.2.4 Temperature sensor, page 39.)</p>	11349182	Stage IV / V (Tier 4f)
6	 <p>SCR NH3 sensor (For more information see: 2.2.5 NH3 control unit with NH3 sensor, page 41.)</p>	10144038	Stage IV / V (Tier 4f)
7	 <p>NH3 control unit (For more information see: 2.2.5 NH3 control unit with NH3 sensor, page 41.)</p>	10144039	Stage IV / V (Tier 4f)

Item		Name	Ident. no.	Exhaust system
8		Differential pressure sensor (For more information see: 2.2.6 Differential pressure sensor, page 43.)	10127114	Stage V
9		Short suction module (372 mm)	12503114	Stage IV / V (Tier 4f)
10		Medium suction module (635 mm)	12503117	
11		Long suction module (681.5 mm) (For more information see: 2.2.7 Suction module, page 45.)	12503120	
12		Castrol paste	11936175	Stage IV / V (Tier 4f)
13		Air line (For more information see: 2.2.8 Air line, page 48.)	11621764	Stage IV / V (Tier 4f)
14		Coupling (For more information see: 2.2.8 Air line, page 48.)	11922682	Stage IV / V (Tier 4f)
15		Air Hose Removal Tool (see: fig. 49, page 35)	11621284	Stage IV / V (Tier 4f)
16		Servicing cap	11922544	Stage IV / V (Tier 4f)
17		Cable tie, heat resistant	11234767	Stage IV / V (Tier 4f)
18		Clamp, clamping range 13 mm to 19 mm	11925110	Stage IV / V (Tier 4f)
19		Service plug Classic4 to 23 mm	11270920	Stage IV / V (Tier 4f)
20		Hose clamp pliers	13192866	Stage IV / V (Tier 4f)

Article list spare parts case for SCR system

Item	Name	Ident. no.	Exhaust system
21	 Hose clamps	12102616	Stage IV / V (Tier 4f)

Tab. 4: Article list spare parts case for SCR system



## 1.7 Tool list (not included)

Make sure that the following tools are at hand:

	Name	Value
	Wrench	8, 10, 12, 14, 17, 22 mm
	Hexagon socket	8, 10, 14, 17, 22 mm
	Hexagon inset socket	5 mm
	Slotted screwdriver	4 mm L = 100 / 185 mm
	All-purpose scissors	200 mm
	Torque wrench	5 to 60 mm 60 to 320 mm
	Marker	<i>Edding paint marker, white</i>

Tab. 5: Tool list

Tool list (not included)

---

Repair 2

---

---

## 2 Repair

---

# 2 Repair

## 2.1 Preparing for repair

### 2.1.1 Repair process

The repair process is carried out according to the following instructions:

#### SCR error

- Machine operator information appears on machine operator display.
- Inform service personnel about SCR error.
- Automatic error transmission via LiDAT by SMS or e-mail possible (only for LiDAT license customers).

#### Error analysis

- Use LiDIA Light for troubleshooting.
- Identify defective component.

#### Repair

- Determine installation position of defective component.
- Determine repair instructions.
- New component can be taken from spare parts case for SCR system. After successful repair, the component missing in the spare parts case for SCR system can be reordered.
- Perform function test with LiDIA.

#### Normal operation

- Repairing the defective component automatically resets the error. Work can be continued without power reduction.

### 2.1.2 Preconditions

Exclude the following possible causes of error before exchanging components:

- Loose connections on the plugs
- Moisture in electric plugs
- Loose lines
- Damaged lines
- Loose attachments
- Fluid level of reduction agent(s)



---

#### WARNING

Inadmissible or improper procedure!  
Severe injuries, damage to machine.

If the information in the repair manual is insufficient or in case of ambiguities:

- ▶ Contact Liebherr customer service.
-

Make sure the following preconditions are met:

- Machine is switched off.
- Main battery switch OFF.
- Machine is secured against unauthorized startup.
- Diesel engine has cooled down.
- Analysis software LiDIA Light is available.

Depending on machine type, it is necessary to remove covers access in order to freely access the exhaust system.

### 2.1.3 Performing diagnosis

To establish a connection between electronic control unit (ECU) and notebook, the notebook must be connected with the *CanFox* diagnosis cable to the diagnosis plug of the machine and LiDIA must be started.



#### Note

The diagnosis plug is located near the main battery switch or the SCR control lamp.



Fig. 41: Diagnosis plug on machine

- 1 Diagnosis plug
- ▶ Remove protective cap.



Fig. 42: CanFox diagnosis cable

- ▶ Plug CanFox diagnosis cable into diagnosis plug 1.
- ▶ Plug CanFox diagnosis cable into laptop.
- ▶ Start LiDIA.

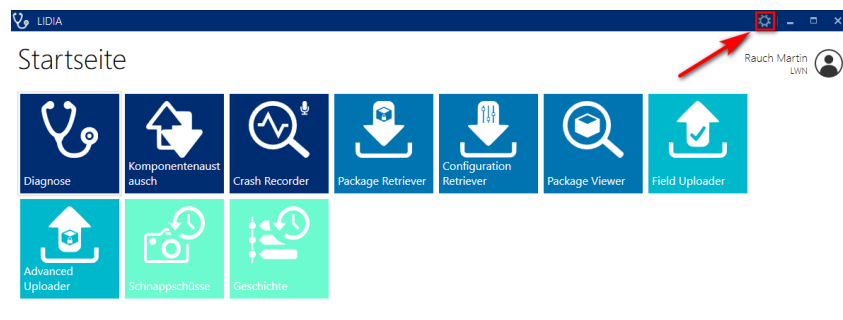

Fig. 43: Clicking button settings on the monitor

- ▶ Click button *Settings* on the monitor.

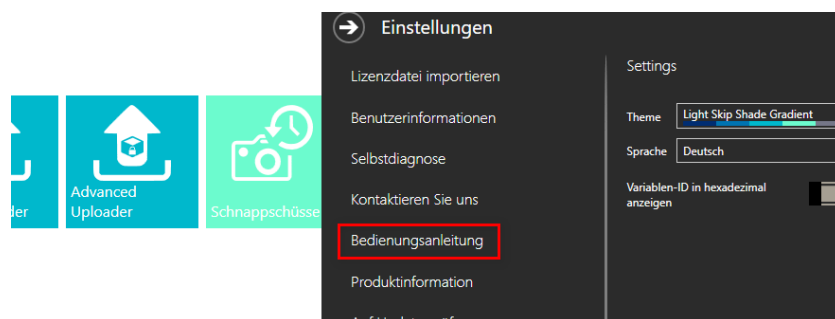

Fig. 44: Clicking button operating manual on the monitor

- ▶ Click button *Operating manual* on the monitor.
- ▶ Perform diagnosis in accordance with LiDIA operating manual.

## 2.2 Performing repair

### 2.2.1 Injector with sealing

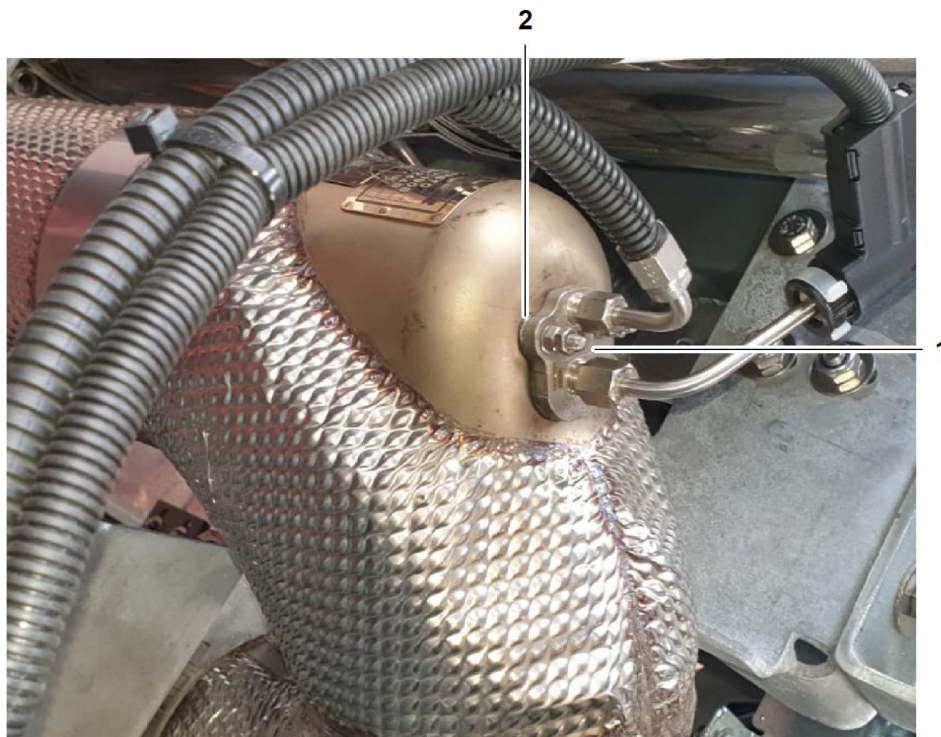

Fig. 45: Installation situation of injector with sealing

- 1 Injector
- 2 Sealing

Make sure that the following spare parts from the spare parts case for SCR system are at hand:

- Injector **1**
- Sealing **2**
- Castrol paste **12**
- Servicing cap **16**
- Service plug Classic **19**

Make sure that the following tools are at hand:

- Wrench 8 mm
- Wrench 14 mm
- Torque wrench
- Socket wrench 8 mm
- Socket wrench 14 mm



## Uninstalling injector with sealing

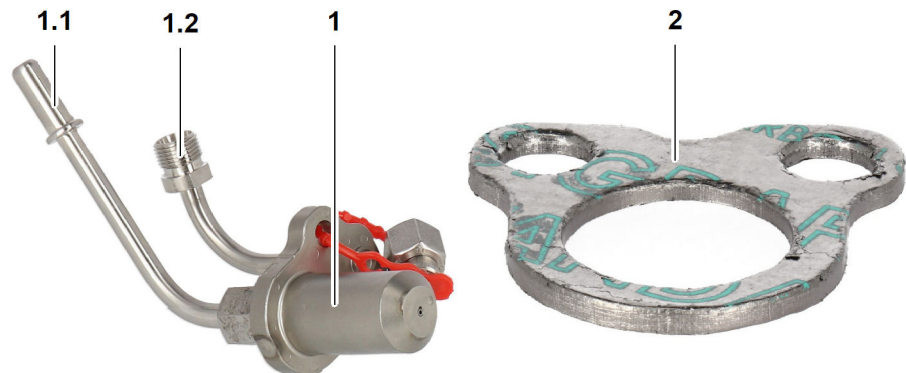

Fig. 46: Uninstalling injector with sealing

- 1 Injector
- 1.1 Connection urea line
- 1.2 Connection air line
- 2 Sealing
- ▶ Undo air line at air line connection 1.2.
- ▶ Close opening with servicing cap 16.
- ▶ Undo urea line at urea line connection 1.1.
- ▶ Close opening with service plug Classic 19.
- ▶ Undo counter nuts.
- ▶ Undo fastening nuts: detach defective injector 1.
- ▶ Remove sealing 2.
  - ▷ Defective injector 1 with sealing 2 is deinstalled.

## Installing injector with sealing

- ▶ Position sealing 2 between exhaust mixing pipe and injector 1.
- ▶ Wet thread with Castrol paste 12.
- ▶ Position injector 1.
- ▶ To install Injector 1: tighten fastening nuts with a tightening torque of 6 Nm.
- ▶ Secure both fastening nuts with one counter nut each.
- ▶ Install air line.
- ▶ Install urea line.
- ▶ Perform functional test with LiDIA.
  - ▷ Injector 1 is installed.

## 2.2.2 Urea pump

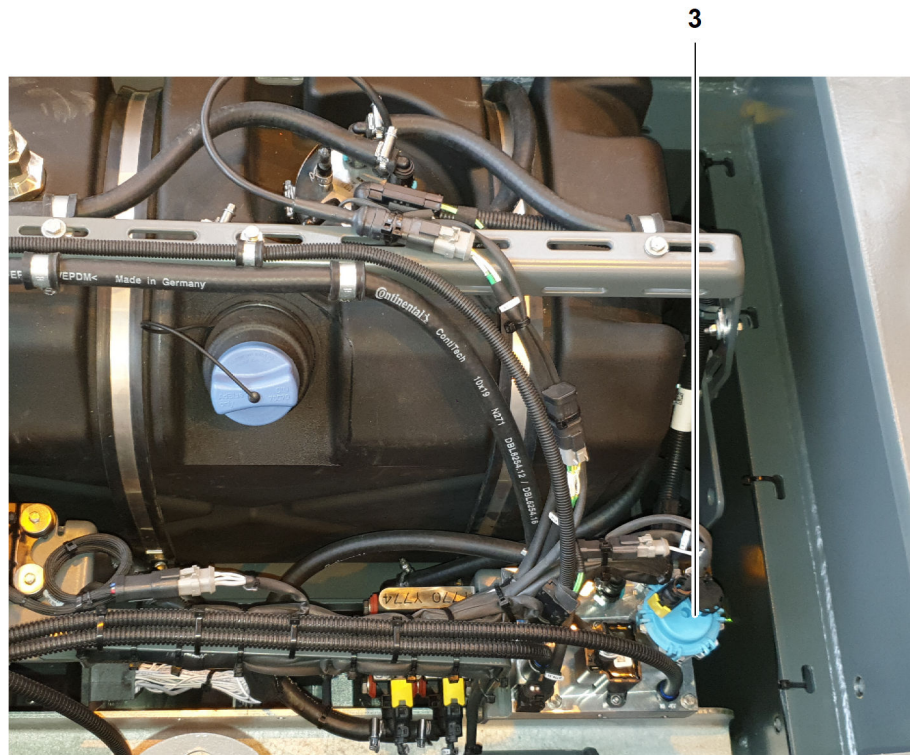

Fig. 47: Installation situation urea pump

### 3 Urea pump

---

#### NOTICE

Improper handling of electrical lines!  
Damage to urea pump

- ▶ Make sure that none of the electrical lines interfere with the repair.
- 

Make sure that the following spare parts from the spare parts case for SCR system are at hand:

- Urea pump **3**
- Air Hose Removal Tool **15**
- Servicing cap **16**
- Clamp **18**
- Service plug Classic **19**

Make sure that the following tools are at hand:

- Wrench 10 mm
- Wrench 17 mm
- Torque wrench
- Slotted screwdriver
- Socket wrench 10 mm
- Hexagon inset socket wrench 5 mm
- Marker

## Deinstalling urea pump

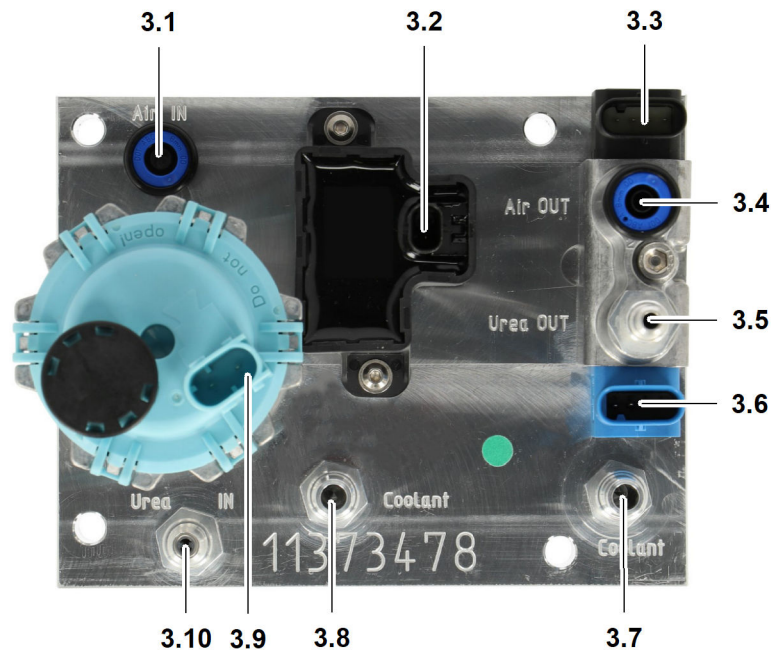

Fig. 48: Deinstalling urea pump

<b>3.1</b>	Connection Air inlet	<b>3.6</b>	Connection DEF pressure and temperature sensor
<b>3.2</b>	Connection Switch over valve	<b>3.7</b>	Connection Coolant outlet
<b>3.3</b>	Connection Air pressure Sensor	<b>3.8</b>	Connection Coolant inlet
<b>3.4</b>	Connection Air outlet	<b>3.9</b>	Connection DEF-Pump
<b>3.5</b>	Connection DEF-outlet	<b>3.10</b>	Connection DEF-inlet

- ▶ Due to risk of confusion, mark coolant lines with marker.
- ▶ Close coolant lines with clamp **18**.
- ▶ Undo quick latch coupling at connection *Coolant outlet* **3.7**.
- ▶ Close opening with service plug Classic **19**.
- ▶ Undo quick latch coupling at connection *Coolant inlet* **3.8**.
- ▶ Close opening with service plug Classic **19**.

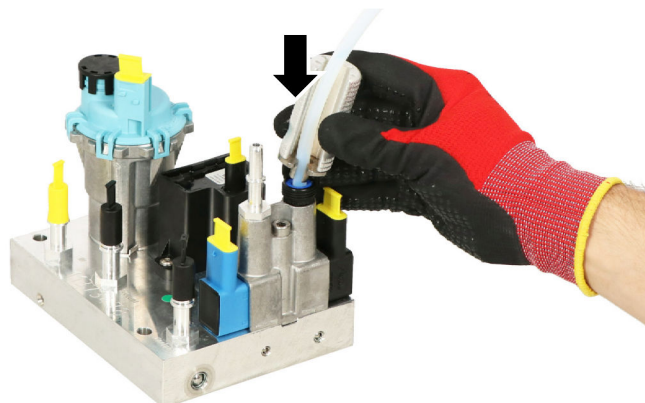

Fig. 49: Positioning Air Hose Removal Tool

- ▶ Position Air Hose Removal Tool **15** at air line connection *Air outlet* **3.4**.

- ▶ Press Air Hose Removal Tool **15** firmly into seat.



Fig. 50: Pulling out air line

- ▶ Undo air line at connection *Air outlet 3.4* with Air Hose Removal Tool **15** by pulling it off.
- ▶ Close opening with servicing cap **16**.
- ▶ Undo air line at connection *Air inlet 3.1* with Air Hose Removal Tool **15** by pulling it off.
- ▶ Close opening with servicing cap **16**.
- ▶ Due to risk of confusion, mark urea lines with marker.
- ▶ Undo quick lock of urea line at connection *DEF-outlet 3.5*.
- ▶ Close opening with service plug Classic **19**.
- ▶ Undo urea line at connection *DEF-inlet 3.10*.
- ▶ Close opening with service plug Classic **19**.
- ▶ Unplug plug at connection *Switch over valve 3.2*.
- ▶ Unplug plug at connection *Air pressure Sensor 3.3*.
- ▶ Unplug plug at connection *DEF pressure and temperature Sensor 3.6*.
- ▶ Unplug plug at connection *DEF-Pump 3.9*.
- ▶ To undo fastening screws: disassemble defective urea pump **3**.
  - ▷ Defective urea pump **3** is deinstalled.

## Installing urea pump

### NOTICE

Improper assembly of urea line or coolant lines!  
Damage to diesel engine or SCR exhaust system.

- ▶ Install marked coolant lines at correct connections.
- ▶ Install marked urea lines at correct connections.

**Note**

It must be possible to connect the quick latch couplings with minimal force. Listen for the "clicking noise" of the quick latch coupling.

- ▶ Position urea pump **3**.
- ▶ To install urea pump **3**: tighten fastening screw with a tightening torque of **7 Nm**.
- ▶ Install urea line at connection *DEF-inlet* **3.10**.
- ▶ Install urea line at connection *DEF-outlet* **3.5**.
- ▶ Install air line at connection *Air inlet* **3.1**.
- ▶ Install air line at connection *Air outlet* **3.4**.
- ▶ Install coolant line at connection *Coolant outlet* **3.7**.
- ▶ Install coolant line at connection *Coolant inlet* **3.8**.
- ▶ Plug in plug at connection *Switch over valve* **3.2**.
- ▶ Plug in plug at connection *Air pressure Sensor* **3.3**.
- ▶ Plug in plug at connection *DEF pressure and temperature Sensor* **3.6**.
- ▶ Plug in plug at connection *DEF-Pump* **3.9**.
- ▶ Perform functional test with LiDIA.
  - ▷ Urea pump **3** is installed.

### 2.2.3 NOx sensor

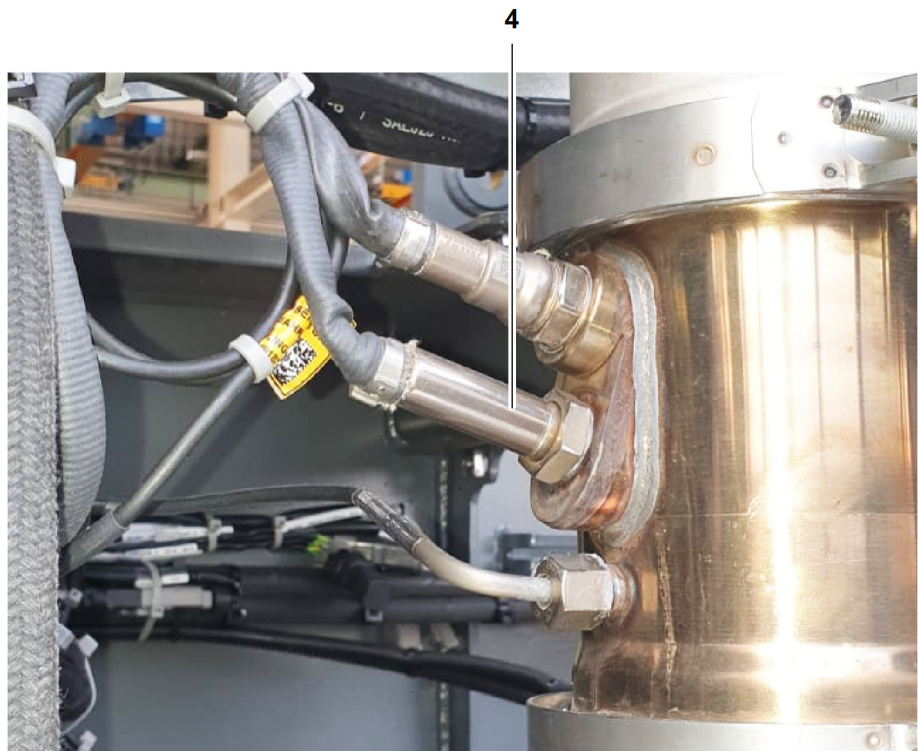

Fig. 51: Installation situation NOx sensor

4 NOx sensor

Make sure that the following spare parts from the spare parts case for SCR system are at hand:

- NOx sensor 4
- Cable tie 17, heat resistant

Make sure that the following tools are at hand:

- Wrench 10 mm
- Wrench 22 mm
- Torque wrench
- Socket wrench 10 mm
- Socket wrench 22 mm
- All-purpose scissors

## Uninstalling NOx sensor

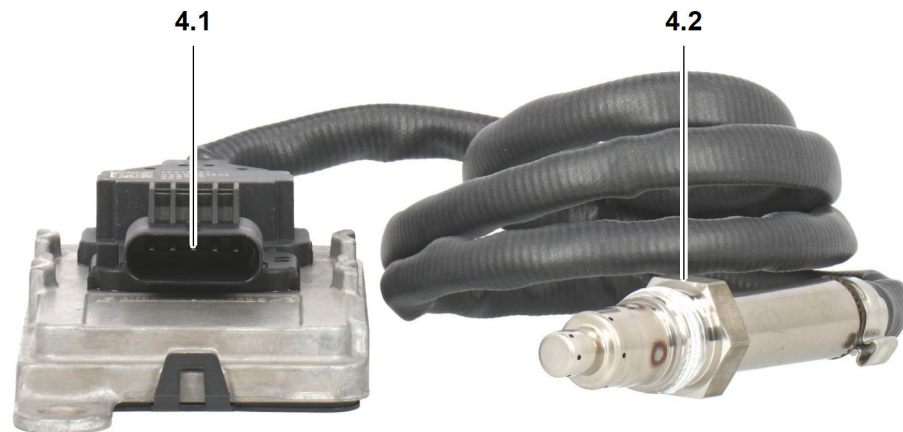

Fig. 52: Uninstalling NOx sensor

**4.1** Connection electric plug                      **4.2** Connection NOx sensor

- ▶ Use all-purpose scissors to expose defective NOx sensor 4.
- ▶ Undo NOx sensor 4 at connection NOx sensor 4.2.
- ▶ Unplug electric plug at connection electric plug 4.1.
- ▶ To undo fastening screws and fastening nuts: detach defective NOx sensor housing.
  - ▷ Defective NOx sensor 4 is deinstalled.

## Installing NOx sensor

- ▶ Position NOx sensor 4.
  - ▶ To install sensor housing: tighten M6 fastening screws with a tightening torque of **7 Nm**.
- or
- ▶ To install sensor housing: tighten M8 fastening screws with a tightening torque of **17 Nm**.
  - ▶ Tighten NOx sensor with a tightening torque of **50 Nm**.
  - ▶ Plug in electric plug at connection electric plug 4.1.
  - ▶ Attach NOx sensor 4 with cable tie 17.
  - ▶ Perform functional test with LiDIA.
    - ▷ NOx sensor 4 is installed.

## 2.2.4 Temperature sensor

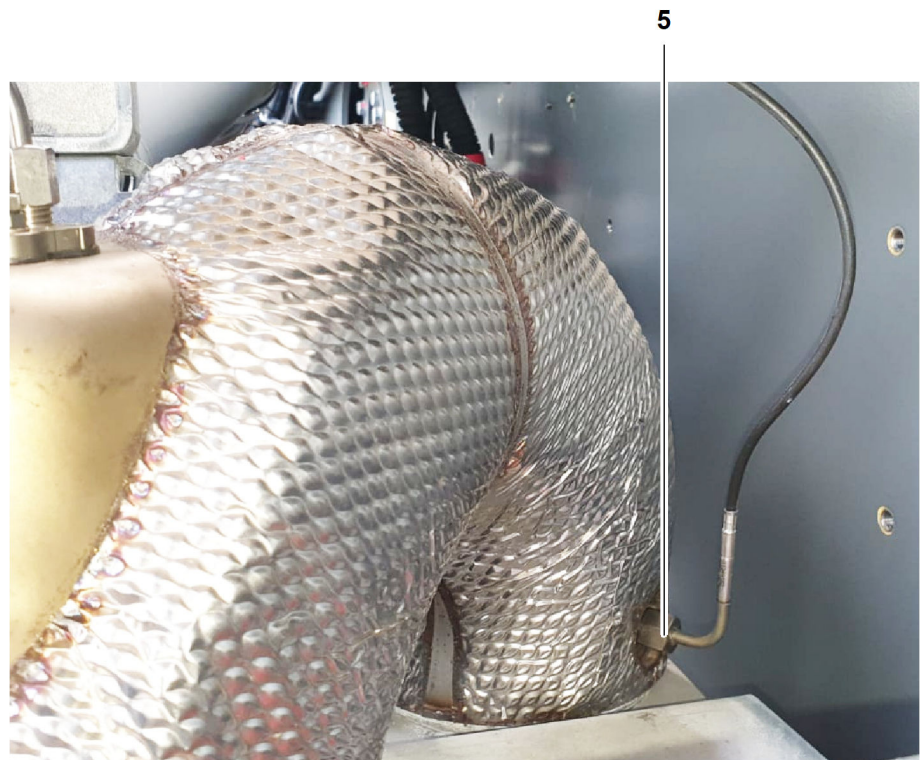

*Fig. 53: Installation situation temperature sensor*

### 5 Temperature sensor

Make sure that the following spare parts from the spare parts case for SCR system are at hand:

- Temperature sensor **5**
- Castrol paste **12**
- Cable tie **17**, heat resistant

Make sure that you have the following tools at hand:

- Wrench 17 mm
- Socket wrench 17 mm
- Torque wrench
- All-purpose scissors

## Deinstalling temperature sensor

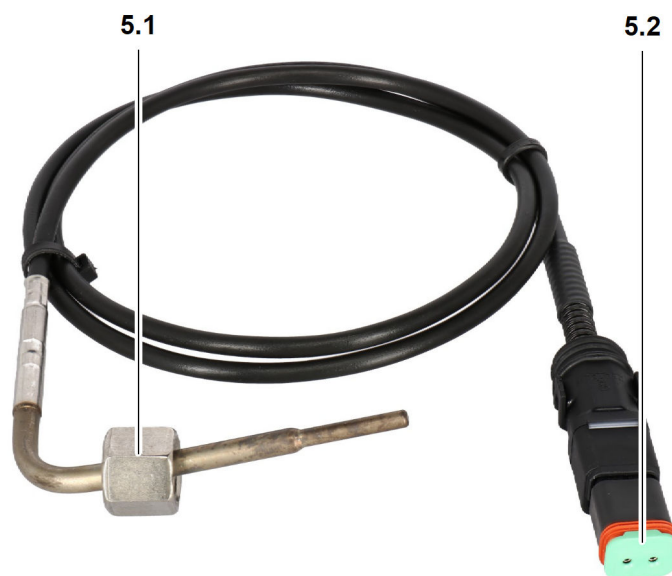

Fig. 54: Deinstalling temperature sensor

**5.1** Fastening nut

**5.2** Electric plug

- ▶ Unplug electric plug **5.2**.
- ▶ Use all-purpose scissors to expose temperature sensor **5**.
- ▶ To undo fastening nut **5.1**: disassemble defective temperature sensor **5**.
  - ▷ Defective temperature sensor **5** is deinstalled.

## Installing temperature sensor

- ▶ Wet thread of exhaust system branch with Castrol paste **12**.
- ▶ To install temperature sensor **5**: tighten fastening nut with a tightening torque of **35 Nm**.
- ▶ Plug in electric plug **5.2**.
- ▶ Attach temperature sensor **5** with cable tie **17**.
- ▶ Perform functional test with LiDIA.
  - ▷ Temperature sensor is installed.



## 2.2.5 NH3 control unit with NH3 sensor

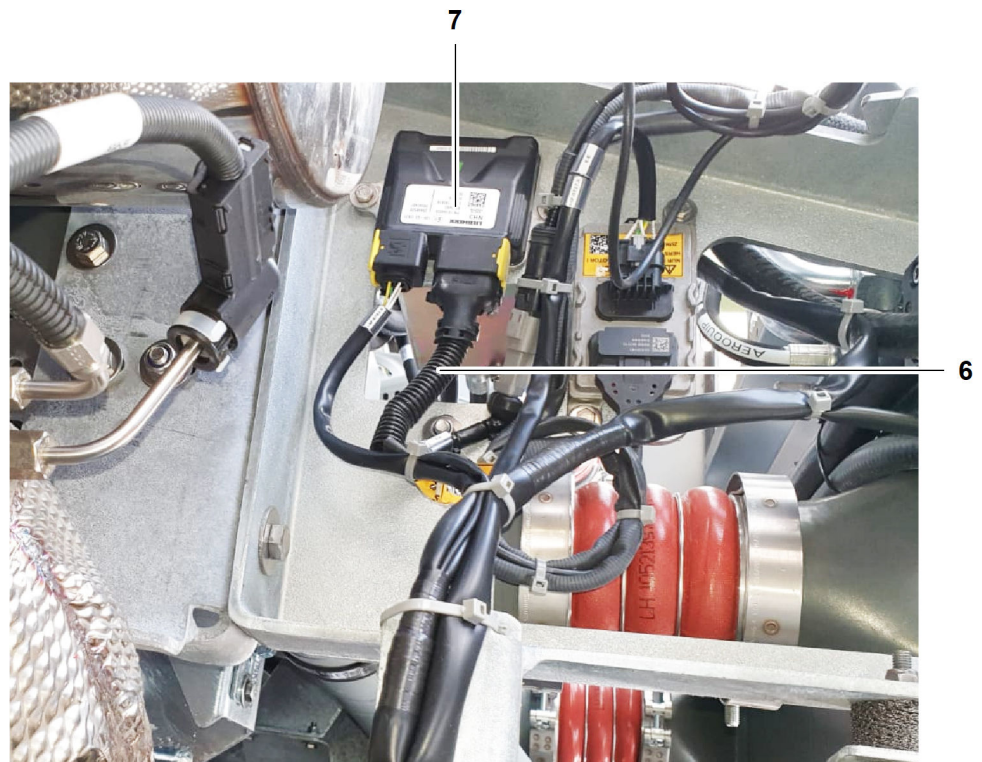

Fig. 55: Installation situation NH3 control unit with NH3 sensor

6 NH3 sensor

7 NH3 control unit

Make sure that the following spare parts from the spare parts case for SCR system are at hand:

- NH3 sensor 6
- NH3 control unit 7
- Castrol paste 12
- Cable tie 17, heat resistant

Make sure that the following tools are at hand:

- Wrench 10 mm
- Wrench 22 mm
- Torque wrench
- Socket wrench 10 mm
- Socket wrench 22 mm
- All-purpose scissors

## Deinstalling NH3 sensor



Fig. 56: Deinstalling NH3 control unit with NH3 sensor

- |                                  |                                       |
|----------------------------------|---------------------------------------|
| <b>6.1</b> Attachment NH3 sensor | <b>7.1</b> Connection electric plug   |
| <b>6.2</b> NH3-sensor plug       | <b>7.2</b> Connection NH3 sensor plug |

- ▶ Use all-purpose scissors to expose NH3 sensor **6**.
- ▶ Unplug NH3-sensor plug **6.2** at connection NH3 sensor plug **7.2**.
- ▶ To undo fastening nut: detach defective NH3 sensor **6**.
  - ▷ Defective NH3 sensor **6** is deinstalled.

## Deinstalling NH3 control unit

- ▶ Unplug electric plug at connection electric plug **7.1**.
- ▶ To undo fastening screws: detach defective NH3 control unit **7**.
  - ▷ Defective NH3 control unit **7** with NH3 sensor **6** is deinstalled.

## Installing NH3 control unit

- ▶ Position NH3 control unit **7**.
- ▶ To install NH3 control unit **7**: tighten fastening screws with a tightening torque of **10 Nm to 13 Nm**.
- ▶ Plug in electric plug at connection electric plug **7.1**.
  - ▷ NH3 control unit **7** is installed.

## Installing NH3 sensor

- ▶ Wet thread of NH3-sensor **6** with Castrol paste **12**.
- ▶ Position NH3 sensor **6**.
- ▶ Tighten NH3 sensor **6** with a tightening torque of **50 Nm**.
- ▶ Plug in NH3 control unit **7**.
- ▶ Attach NH3 sensor **6** with cable tie **17**.
- ▶ Perform functional test with LiDIA.
  - ▷ NH3 control unit **7** with NH3 sensor **6** is installed.

## 2.2.6 Differential pressure sensor

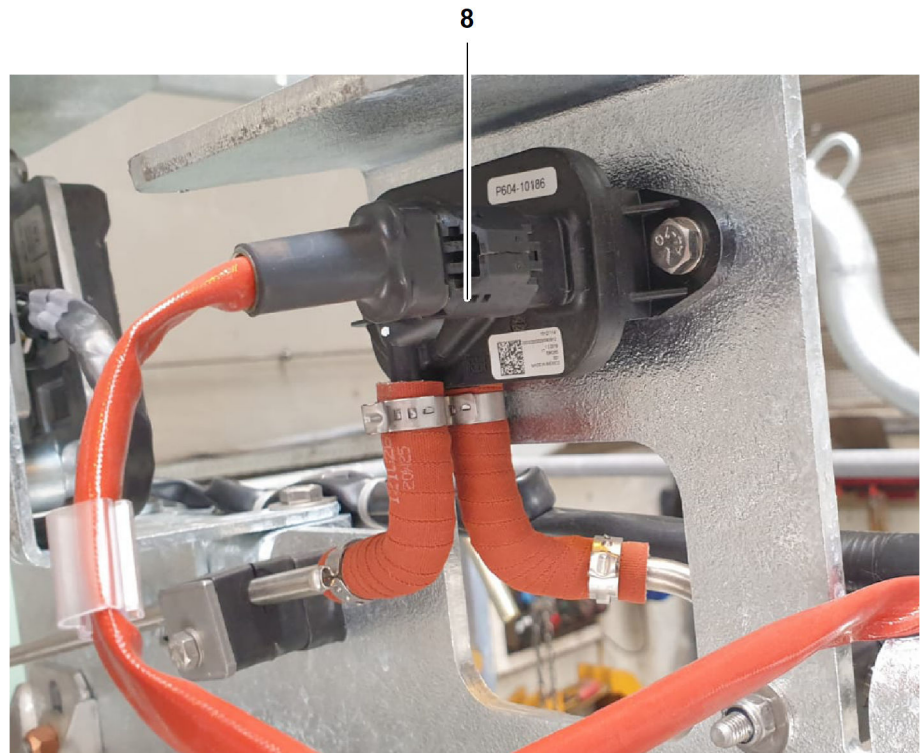

Fig. 57: Installation situation differential pressure sensor

### 8 Differential pressure sensor

Make sure that the following spare parts from the spare parts case for SCR system are at hand:

- Differential pressure sensor **8**
- Hose clamp pliers **20**
- Hose clamp **21**

Make sure that the following tools are at hand:

- Slotted screwdriver
- Wrench 10 mm
- Wrench 17 mm
- Torque wrench
- Socket wrench 10 mm
- All-purpose scissors
- Marker

## Deinstalling differential pressure sensor



Fig. 58: Deinstalling differential pressure sensor

**8.1** Connection electric plug                      **8.3** Connection air line

**8.2** Connection air line

- ▶ Due to risk of confusion, mark air lines with marker.
- ▶ To undo clamps at connection air line **8.2** and connection air line **8.3**: detach air lines.
- ▶ Unplug electric plug at connection electric plug **8.1**.
- ▶ To undo fastening screws: detach defective differential pressure sensor **8**.
  - ▷ Defective differential pressure sensor **8** is deinstalled.

## Installing differential pressure sensor

- ▶ Position differential pressure sensor **8**.
- ▶ To install differential pressure sensor **8**: tighten fastening screw with a tightening torque of **6 Nm**.

---

### NOTICE

Incorrect handling of air lines!  
Damage to connections.

- ▶ Install air lines at correctly marked position on differential pressure sensor.
  - ▶ Be careful when connecting air lines.
- 

- ▶ Install air lines at connection air line **8.2** and connection air line **8.3** with hose clamps **21**.
- ▶ Press hose clamps **21** together with hose clamp pliers **20**.
- ▶ Plug in electric plug at connection electric plug **8.1**.

- ▶ Perform functional test with LiDIA.
  - ▷ Differential pressure sensor **8** is installed.

## 2.2.7 Suction module

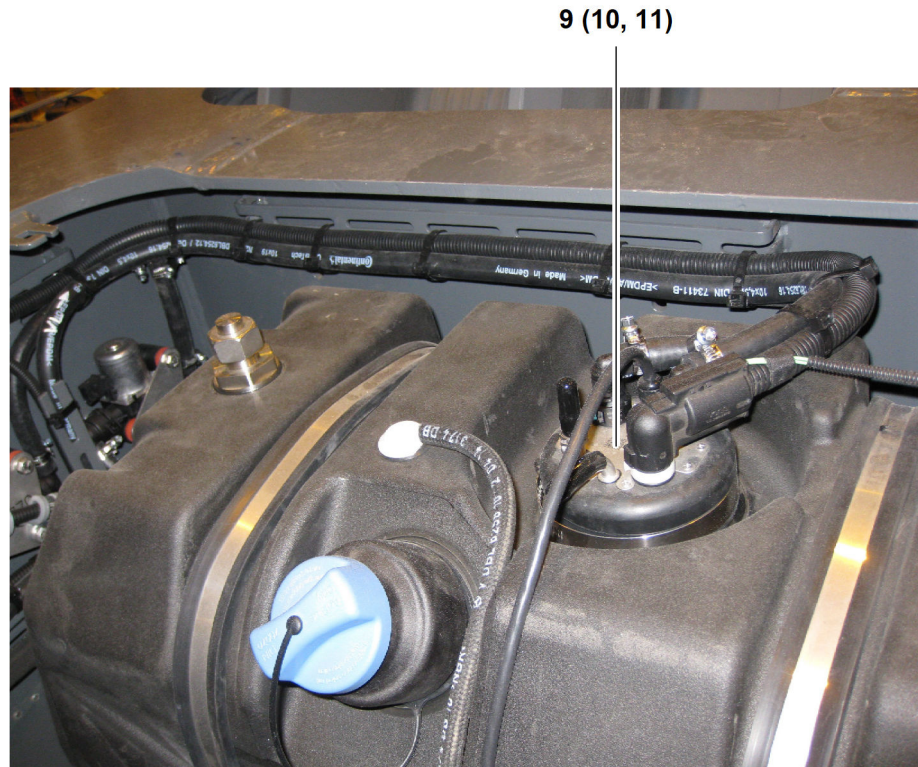

Fig. 59: Installation situation suction module

### 9 Suction module

Make sure that the following spare parts from the spare parts case for SCR system are at hand:

- Suction module **9**
- Clamp **18**
- Service plug Classic **19**

Make sure that the following tools are at hand:

- Slotted screwdriver
- Wrench 8 mm
- All-purpose scissors
- Marker

## Deinstalling suction module

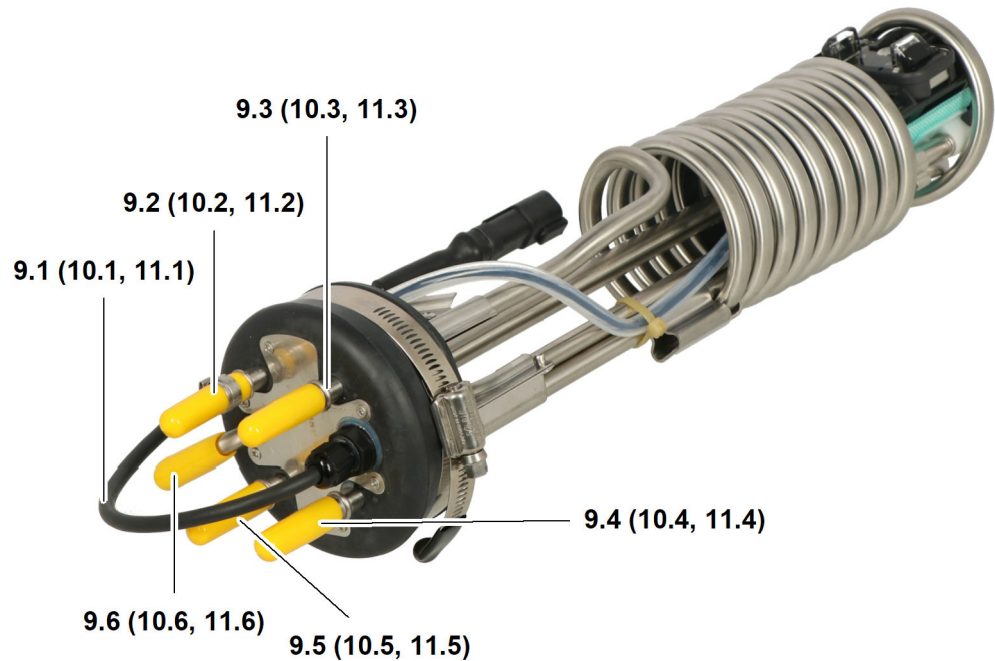

Fig. 60: Deinstalling suction module

<b>9.1</b> Electric plug	<b>9.4</b> Connection coolant line Coolant IN
<b>9.2</b> Connection urea line DEF IN	<b>9.5</b> Connection urea line DEF OUT
<b>9.3</b> Connection coolant line Coolant OUT	<b>9.6</b> Connection VENT

- ▶ Due to risk of confusion, mark coolant lines with marker.
- ▶ Close coolant lines at connection coolant line Coolant OUT **9.3** and connection coolant Line Coolant IN **9.4** with clamp **18**.
- ▶ Undo quick latch couplings at connection coolant line Coolant OUT **9.3** and connection coolant line Coolant IN **9.4**.
- ▶ Close openings with service plugs Classic **19**.
- ▶ Due to risk of confusion, mark urea lines with marker.
- ▶ Undo quick latch couplings at connection urea line DEF IN **9.2** and connection urea line DEF OUT **9.5**.
- ▶ Close opening with service plug Classic **19**.
- ▶ Unplug electric plug **9.1**.
- ▶ Deinstall clamp at connection VENT **9.6** at defective suction module.
- ▶ Deinstall defective suction module **9**.
  - ▷ Defective suction module **9** is deinstalled.

## Installing suction module

---

### NOTICE

Improper assembly of urea line or coolant lines!  
Damage to diesel engine or SCR exhaust system.

- ▶ Install marked coolant lines at correct connections.
  - ▶ Install marked urea lines at correct connections.
- 



### Note

It must be possible to connect the quick latch couplings with minimal force. Listen for the "clicking noise" of the quick latch coupling.

---

- ▶ Position suction module **9**.
- ▶ To install suction module **9**: tighten clamp with a tightening torque of **1.5 Nm**.
- ▶ Plug in electric plug **9.1**.
- ▶ Connect urea line with quick latch coupling to connection urea line DEF IN **9.2** and connection urea line DEF OUT **9.5**.
- ▶ Connect coolant lines with quick latch coupling to connection coolant line Coolant OUT **9.3** and connection coolant line Coolant IN **9.4**.
- ▶ Install clamp at connection VENT **9.6**.
- ▶ Perform functional test with LiDIA.
  - ▷ Suction module **9** is installed.

## 2.2.8 Air line

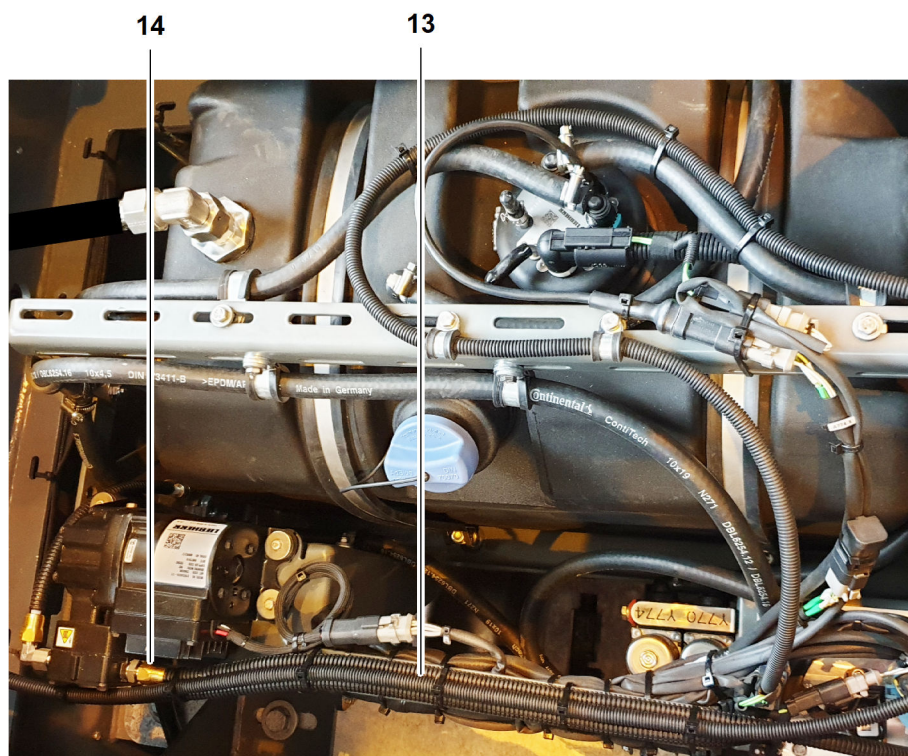

Fig. 61: Installation situation air line

**13** Air line

**14** Wira- coupling

Make sure that the following spare parts from the spare parts case for SCR system are at hand:

- Air line **13**
- Wira- coupling **14**
- Air Hose Removal Tool **15**
- Servicing cap **16**
- Cable tie **17**, heat resistant

Make sure that the following tools are at hand:

- Wrench 17 mm
- All-purpose scissors



## Deinstalling air line

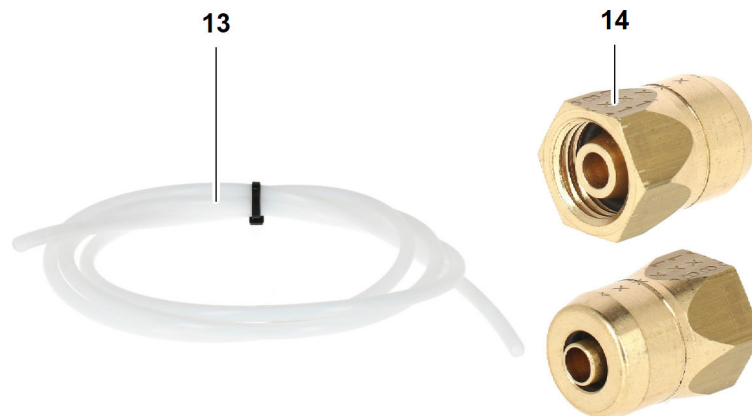

Fig. 62: Deinstalling air line

**13** Air line

**14** Wira- coupling

If the defective air line **13** must be detached from the urea pump, detach the air hose with the Air Hose Removal Tool **15**.

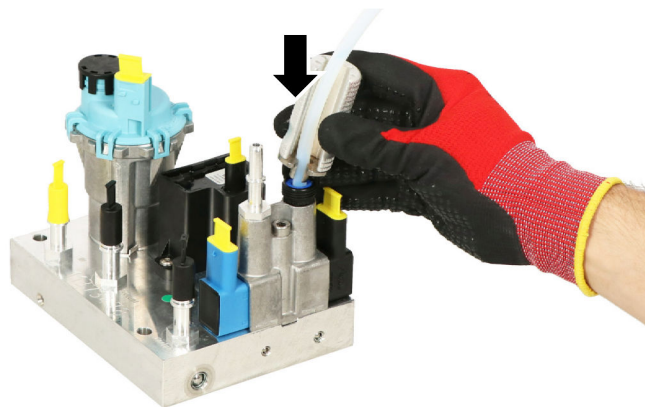

Fig. 63: Positioning Air Hose Removal Tool

- ▶ Use all-purpose scissors to expose defective air line **13**.
- ▶ Position Air Hose Removal Tool **15** on defective air line **13**.
- ▶ Press Air Hose Removal Tool **15** firmly into seat.



Fig. 64: Pulling out defective air line

- ▶ Undo defective air line **13** with Air Hose Removal Tool **15** by pulling it off.
- ▶ Close opening with servicing cap **16**.
- ▶ Undo and detach defective air line **11**.
  - ▷ Defective air line **11** is deinstalled.

## Installing air line

- ▶ Cut air line to length. Make sure that no devices are attached to air line.
- ▶ Insert air line into Wira coupling **14**. Perform pulling force test. Air line must be tightly in Wira- coupling **14** with a maximum axial play of 2 mm.

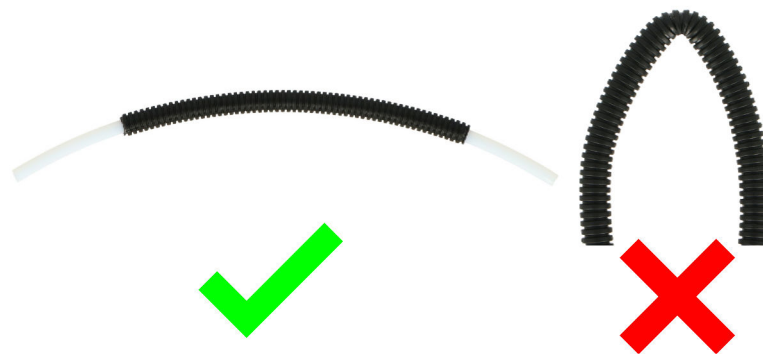

Fig. 65: Correct bending radius

- ▶ Attach air line with cable tie **17**. Observe maximum bending radius of 60 mm. Air line must not be kinked, squeezed or twisted when installed. Condensed water drainage must be ensured.



*Fig. 66: Attaching air line with cable tie*

- ▶ Attach air line with cable tie **17**.
- ▶ Perform functional test with LiDIA.
  - ▷ Air line is installed.



---

Overview of suction modules

---

---

## 3 Overview of suction modules

---

# 3 Overview of suction modules

## 3.1 Construction machinery (LR, HS and FE)

### 3.1.1 Short suction module (Pos. 9, Ident. no. 12503114)

#### LR crawler cranes

Machine type	Engine type	Machine type	Engine type
LR 1110	D 944 A7-04	LR 1200.1	D 944 A7-04
LR 1110	D 944 A7-05	LR 1200.1	D 944 A7-05
LR 1130	D 944 A7-04	LR 1250	D 944 A7-04
LR 1130.1	D 944 A7-04	LR 1250.1	D 944 A7-04
LR 1130.1	D 944 A7-05	LR 1250.1	D 944 A7-05
LR 1160	D 944 A7-04	LR 1300	D 946 A7-04
LR 1160.1	D 944 A7-04	LR 1300.1	D 946 A7-04
LR 1160.1	D 944 A7-05	LR 1300.1	D 946 A7-05
LR 1200	D 944 A7-04	LR 1400	D 966 A7-05

Tab. 6: Short suction module for LR crawler cranes

#### HS cable excavator

Machine type	Engine type	Machine type	Engine type
HS 8070	D 936 A7-04	HS 8100.1	D 946 A7-05
HS 8100	D 946 A7-04		

Tab. 7: Short suction module for HS cable excavator

#### FE deep foundation equipment

Machine type	Engine type	Machine type	Engine type
LRB 16	D 946 A7-04	LB 30	D 936 A7-05
LRB 18	D 946 A7-04	LB 35	D 946 A7-05
LRB 18	D 946 A7-05	LB 36	D 946 A7-04
LB 20	D 936 A7-04	LB 45	D 946 A7-05
LB 24	D 936 A7-04	LB 45	D 946 Tier 4 F
LB 25	D 936 A7-05	LRH 100	D 936 A7-04

Machine type	Engine type	Machine type	Engine type
LB 28	D 946 A7-04	LRH 100.1	D 936 A7-05

Tab. 8: Short suction module for FE deep foundation equipment

### 3.1.2 Medium suction module (Pos. 10, Ident. no. 12503117)

#### HS cable excavator

Machine type	Engine type	Machine type	Engine type
HS 8040.1	D 944 A7-05	HS 8200	D 9512 A7-05
HS 8070.1	D 936 A7-05	HS 8300.1	D 9512 A7-05

Tab. 9: Medium suction module for HS cable excavator

#### FE deep foundation equipment

Machine type	Engine type	Machine type	Engine type
LB 16	D 944 A7-04	LB 20.1	D 944 A7-05

Tab. 10: Medium suction module for FE deep foundation equipment

### 3.1.3 Long suction module (Pos.11, Ident. no. 12503120)

#### HS cable excavator

Machine type	Engine type	Machine type	Engine type
HS 8130	D 9508 A7-04	HS 8130.1	D 9508 A7-05

Tab. 11: Long suction module for HS cable excavator

#### FE deep foundation equipment

Machine type	Engine type	Machine type	Engine type
LRB 355.1	D 9512 A7-05	LB 55	D 9508 A7-05
LB 44	D 9508 A7-04		

Tab. 12: Long suction module for FE deep foundation equipment



## 3.2 Maritime machines

### 3.2.1 Short suction module (Pos. 9, Ident. no. 12503114)

LHM mobile harbour cranes

Machine type	Engine type	Machine type	Engine type
LHM 120	D 946 A7-04	LPS 180	D 946 A7-04
LHM 180	D 946 A7-04	LPS 280	D 946 A7-04
LHM 280	D 946 A7-04		

Tab. 13: Short suction module for LHM mobile harbour cranes

### 3.2.2 Medium suction module (Pos. 10, Ident. no. 12503117)

LRS reachstacker

Machine type	Engine type	Machine type	Engine type
LRS 545	D944 A7-04	LRS 545	D944 A7-05

Tab. 14: Medium suction module for LRS reachstacker

### 3.2.3 Long suction module (Pos.11, Ident. no. 12503120)

LHM mobile harbour cranes

Machine type	Engine type	Machine type	3Motortyp
LHM 420	D9512 A7-05	LPS 420	D9512 A7-05
LHM 550	D9512 A7-04	LPS 550	D9512 A7-05
LHM 600	D9512 A7-05	LPS 600	D9512 A7-05
LHM 800	D9512 A7-05		

Tab. 15: Long suction module for LHM mobile harbour cranes





---

## 4 Part list

---

# 4 Part list

## 4.1 Part list spare parts case for SCR system

Ident. no.	Item	Name	Order amount
10144093	1	Injector	1
10144861	2	Sealing for injector	1
11373478	3	Urea pump	1
12412141	4	NOx sensor	2
11349182	5	Temperature sensor	1
10144038	6	SCR NH3 sensor	1
10144039	7	NH3 control unit	1
10127114	8	Differential pressure sensor	1
12503114	9	Short suction module (372 mm)	1
12503117	10	Medium suction module (635 mm)	1
12503120	11	Long suction module (681.5 mm)	1
11936175	12	Castrol paste	1
11621764	13	Air line	10 m
11922682	14	Wira- coupling	1
11621284	15	Air Hose Removal Tool	1
11922544	16	Servicing cap	10
11234767	17	Cable tie, heat resistant	100
11925110	18	Clamp, clamping range 13 to 19 mm	1
11270920	19	Service plug <i>Classic4</i> to 23 mm	4
13192866	20	Hose clamp pliers	1
12102616	21	Hose clamp	6

Tab. 16: Part list spare parts case for SCR system

## 4.2 Part list optionally available tools

Ident. no.	Name	Order amount
885318214	Wrench, chrome finish 8 mm	1
885318414	Wrench, chrome finish 10 mm	1
885318614	Wrench, chrome finish 12 mm	1
885318814	Wrench, chrome finish 14 mm	1
885319014	Wrench, chrome finish 17 mm	1
885319314	Wrench, chrome finish 22 mm	1
885346914	Hexagonal socket wrench 8 mm	1
885346314	Hexagonal socket wrench 10 mm	1
885312114	Hexagonal socket wrench 14 mm	1
885312214	Hexagonal socket wrench 17 mm	1
885312414	Hexagonal socket wrench 22 mm	1
885365314	Hexagon inset socket wrench 5 mm	1
882320614	All-purpose scissors 200 mm	1
885100214	Slotted screwdriver 4 mm L=100/ 185 mm	1
11951873	Slotted screwdriver Kraftform-Heft L= 125/223/ 1 x 5.5	1
885300614	Torque wrench	1
10566118	Torque wrench 5 to 60 mm	1
10566119	Torque wrench 60 to 320 mm	1
10224670	Marker <i>Edding paint marker, white</i>	1

Tab. 17: Part list optionally available tools

# Index

## A

Air line 48  
Article list spare parts case for SCR system 22

## C

Construction machinery (LR, HS and FE) 55  
Contents of spare parts case for SCR system 20

## D

Deinstalling air line 49  
Deinstalling differential pressure sensor 44  
Deinstalling NH3 control unit 42  
Deinstalling NH3 sensor 42  
Deinstalling suction module 46  
Deinstalling temperature sensor 40  
Deinstalling urea pump 35  
Diagram exhaust stage IV (Tier 4f) 15  
Diagram exhaust stage V 18  
Differential pressure sensor 43  
Distinguishing feature 14  
Distinguishing feature exhaust stage V 17

## G

General 11

## I

Injector with sealing 32  
Installing air line 50  
Installing differential pressure sensor 44  
Installing injector with sealing 33  
Installing NH3 control unit 42  
Installing NH3 sensor 42  
Installing NOx sensor 38  
Installing suction module 47  
Installing temperature sensor 40  
Installing urea pump 36

## L

Long suction module (Pos.11, Ident. no. 12503120) 56, 57

## M

Maritime machines 57  
Medium suction module (Pos. 10, Ident. no. 12503117) 56, 57

## N

NH3 control unit with NH3 sensor 41  
NOx sensor 37

## O

Overview exhaust system exhaust stage IV (Tier 4f) 14  
Overview exhaust system exhaust stage V 17  
Overview of suction modules 55

## P

Part list 61  
Part list optionally available tools 62  
Part list spare parts case for SCR system 61  
Performing diagnosis 30  
Performing repair 32  
Preconditions 29  
Preparing for repair 29  
Product description 11

## R

Repair 29  
Repair process 29

## S

Short suction module (Pos. 9, Ident. no. 12503114) 55, 57  
Suction module 45

## T

Temperature sensor 39  
Tool list (not included) 25

## U

Uninstalling injector with sealing 33  
Uninstalling NOx sensor 38  
Urea pump 34

## W

Warning levels 12