

EN



LRB 19

LRB 2501.08
www.liebherr.com

LIEBHERR

Piling and drilling rigs

Assistance systems



Remote-controlled assembly and disassembly

- The remote control facilitates the safe assembly and disassembly of the machine.
- The operator can change position and thus has a better view of collision points.

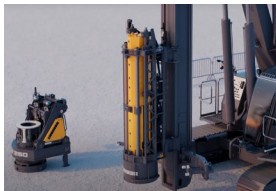

Attachment recognition

- The basic machine's control system detects attachments, records their operating hours and optimises oil quantities and pressures.
- Operating parameters and faults are recorded and can be recalled via LiDAT.



Vibro-assistant

The compaction process for vibro-replacement runs automatically and in compliance with the specified parameters. This ensures consistent quality and simplifies the work process and operation for the driver.



Drilling assistant for single pass method

The rope crowd system, rotary drive and the amount of flowing concrete are optimally matched during drilling and subsequent extraction.

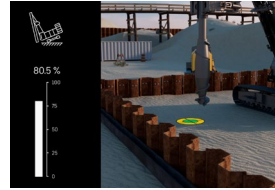

Ground pressure visualisation

Changes in the leader position or swinging the uppercarriage lead to a shift in the centre of gravity. Centres of gravity, load moments and ground pressure distribution under the crawler are calculated in real time.

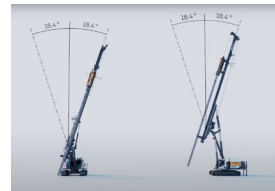

Automatic leader adjustment

The operator can save the leader inclination. At the touch of a button, the leader can be set to the desired inclination at the piling or drilling point for each new working step. This saves time and ensures precise results.

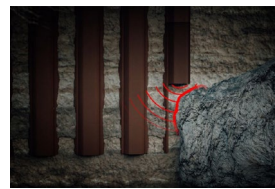

Obstacle recognition

Obstacle recognition enables the timely recognition of unexpected obstacles in the soil when carrying out sheet piling work. This protects both the basic machine and its attachments.

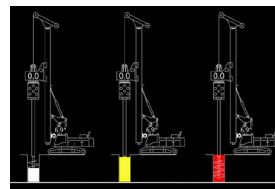

Assistance systems for Kelly drilling

- Automatic shake-off function for working tools
- Kelly visualisation
- Auger filling level display for drilling tools
- Kelly winch with freewheeling and with slack rope monitoring, reduction and limitation
- Crowd booster

Technical description



Diesel engine

Power rating according to ISO 9249	450 kW (603 hp) at 1700 rpm
Engine type	Liebherr D 966 A7-05
Fuel tank capacity	625 l with continuous level indicator and reserve warning
Exhaust certification	EU 2016/1628 Stage V EPA/CARB Tier 4f non-certified emission standard



Hydraulic system

Hydraulic pumps	
for attachments	2x 410 l/min and 2x 340 l/min
for kinematics	140 l/min
Hydraulic oil tank capacity	770 l
Max. working pressure	400 bar
Hydraulic oil	electronic monitoring of all filters use of synthetic environmentally friendly oil possible



Crawlers

Drive system	with fixed axial piston hydraulic motors
Crawler side frames	maintenance-free, with hydraulic chain tensioning device
Brake	hydraulically released, spring-loaded multi-disc holding brake
Drive speed	0-2.5 km/h
Track force	459 kN
Grousers	Width 700 mm (option 800 mm)



Swing gear

Drive system	with fixed axial piston hydraulic motors, planetary gearbox, pinion
Swing ring	single row ball bearing with internal teeth and one swing drive
Brake	hydraulically released, spring-loaded multi-disc holding brake
Swing speed	0-3.4 rpm continuously variable



Crowd system

Crowd force	165/250 kN (push/pull)
Travel	13.4 m
Sledge speed	0-26 m/min



Auxiliary winch

Line pull effective	52 kN (3rd layer)
Swing range	left 0-180°
Radius	900-1830 mm
Rope diameter	17 mm
Rope speed	0-54 m/min
Max. lifting capacity for loading/unloading of attachments	78.5 kN



Kelly winch and additional winch (option)

Line pull effective	110 kN
Rope diameter	20 mm
Rope speed	0-85 m/min

Remarks:

- Illustrations showing the types of application (e.g. Kelly drilling, continuous flight auger drilling etc.) are examples only.
- Weights and transport dimensions can vary with the final configuration of the machine. The figures in this brochure may include options which are not within the standard scope of supply of the machine.

Dimensions

Standard

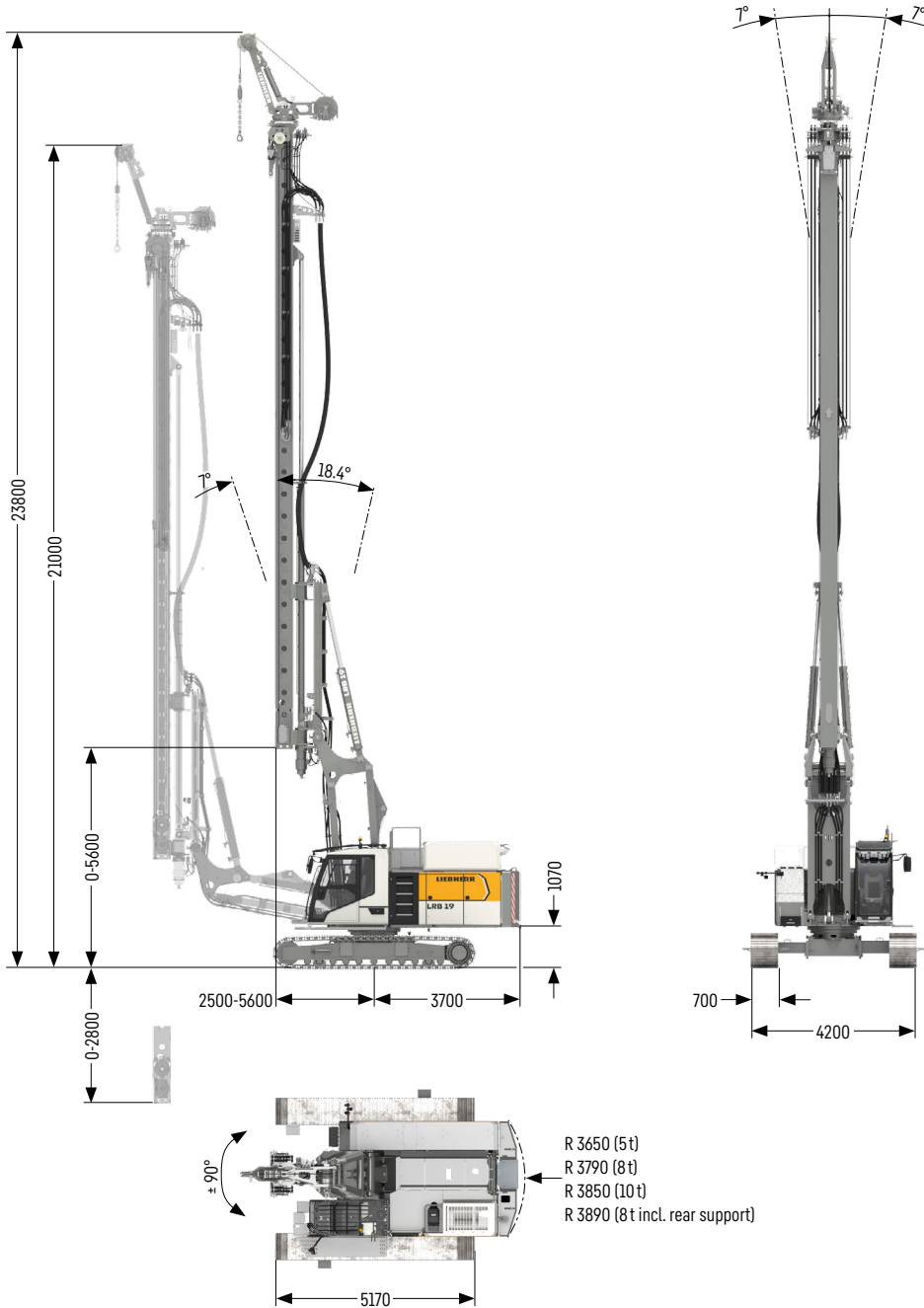

Operating weights

Total weight with 700 mm 3-web grousers	t 48.2
Total weight with 800 mm 3-web grousers	t 48.9

The operating weight includes the basic machine LRB 19 (ready for operation - including 20% filling of diesel tank) with 8 t counterweight, without attachment.

with Kelly winch and additional winch (option)

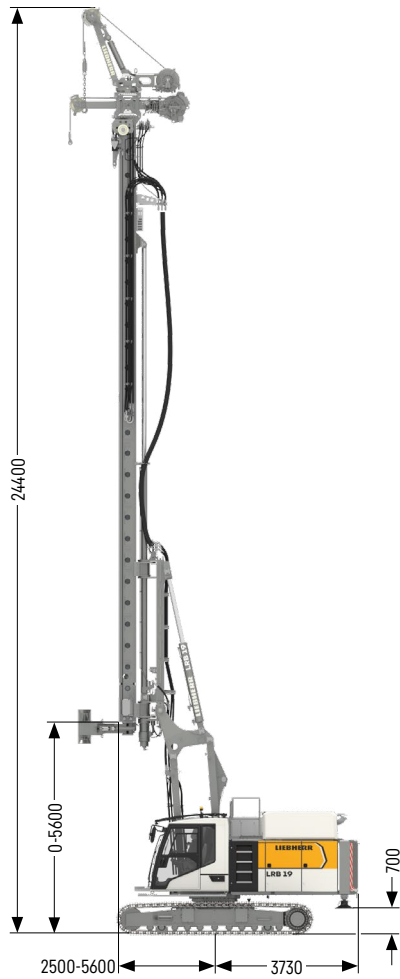

Operating weights

Total weight with 700 mm 3-web grousers	t 50.1
Total weight with 800 mm 3-web grousers	t 50.7

The operating weight includes the basic machine LRB 19 (ready for operation - including 20% filling of diesel tank) with 8 t counterweight, rear support and additional winch, without attachment.

Transport dimensions and weights

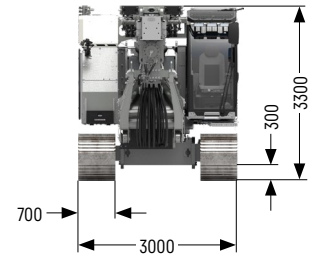
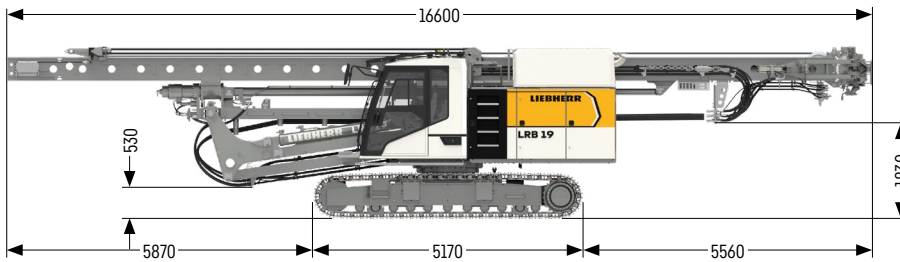

Operating weight

includes the basic machine LRB 19 (ready for operation - including 20% filling of diesel tank) without Kelly winch and additional winch, without counterweight and attachment. t 40.2

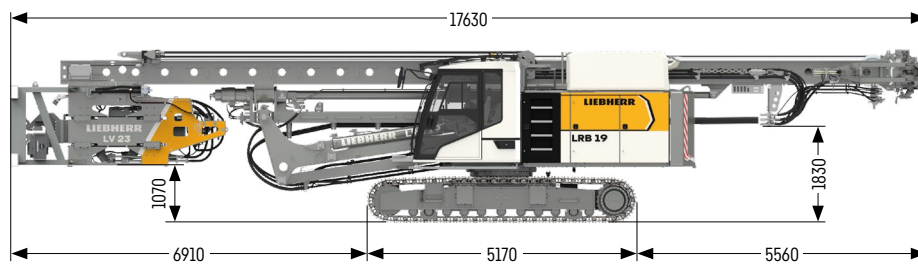

Operating weight with LV 23

includes the basic machine LRB 19 (ready for operation - including 20% filling of diesel tank) with LV 23 and transport frame, 8 t counterweight, without Kelly winch and additional winch. t 53.9

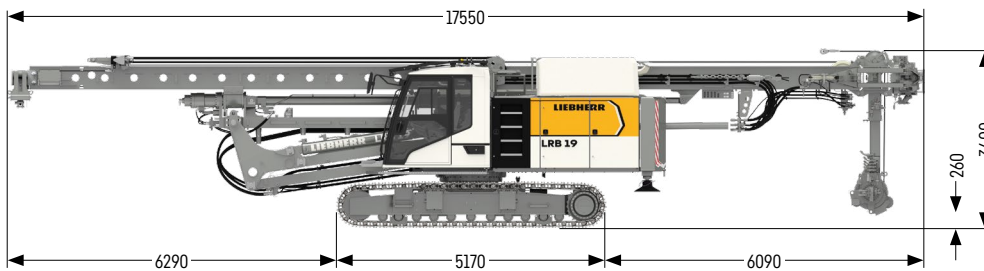

Operating weight with additional winch and rear support

includes the basic machine LRB 19 (ready for operation - including 20% filling of diesel tank) with Kelly winch, additional winch and lower pile guide, 8 t counterweight with rear support, without attachment. t 50.1

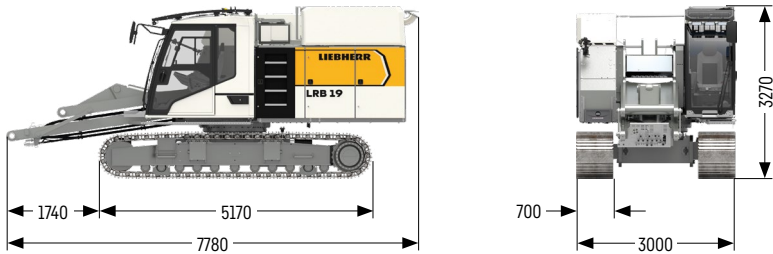

Basic machine

Weight without counterweight	t 29.6
------------------------------	--------

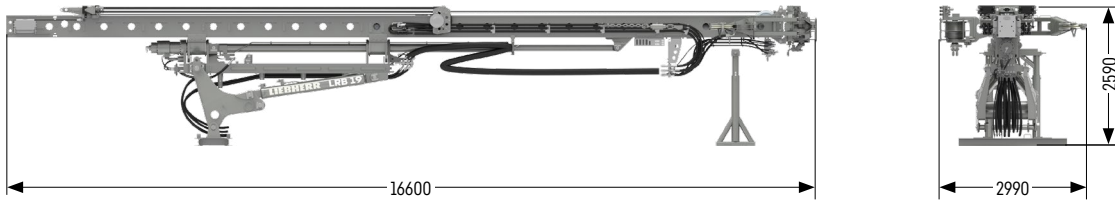

Leader

without Kelly winch and additional winch	t 10.8
--	--------

Options

Concrete supply line	t 0.4
All round platform with railings	t 0.5
Lower pile guide	t 0.5
Kelly winch and additional winch	t 1.5

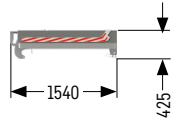
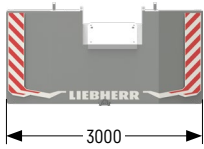

Rear counterweight

Weight t 5.0

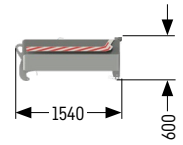
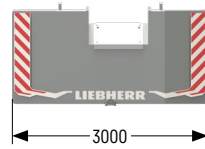

Rear counterweight

Weight t 8.0

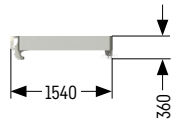
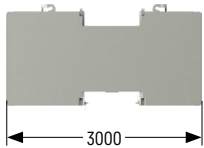

Intermediate slab

Weight t 5.0

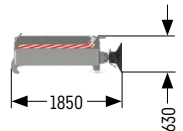
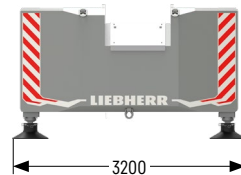

Rear counterweight with rear support

Weight t 8.0

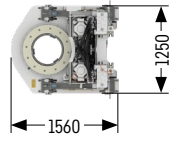
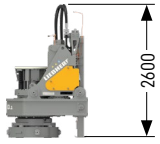

BAT 180.1

Weight t 5.8

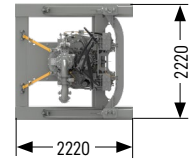
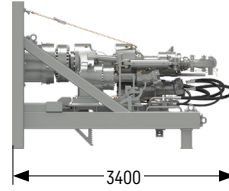

DBA 140

Weight t 6.4

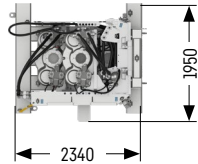
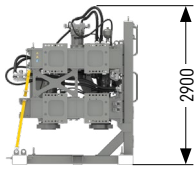

3MA 65

Weight t 7.4

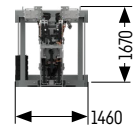
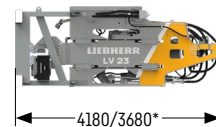

Vibrator slim design LV 23 and LV 23 F

Weight LV 23 t 5.7

Weight LV 23 F t 5.7

* LV 23 F

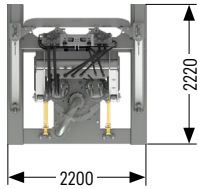
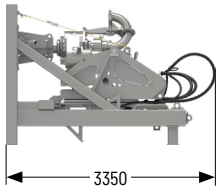

DHR 110

Transport weight t 5.8

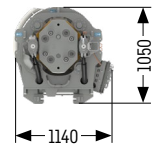
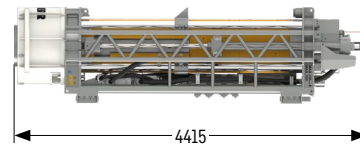

Hammer H 6-6

Weight incl. 6 t drop weight t 9.6

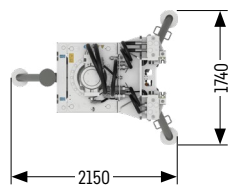
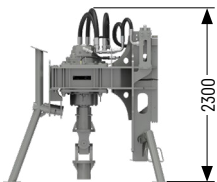

BA 35

Weight t 3.1

Vibrator slim design

LV 23 and LV 23 F



Performance data		LV 23	LV 23 F
Static moment	kgm	0-23	0-23
Max. frequency	rpm	0-2400	0-2400
Max. centrifugal force	kN	1200	1200
Max. peak-to-peak amplitude with 140 t clamp	mm	14.3	13.9
Total weight with 140 t clamp	kg	5170	5170
Dynamic weight including 140 t clamp	kg	3170	3260
Max. recommended pile length	m	18.0	17.9
Vibrator width in piling axis	mm	460	770
Piling axis	mm	900	900
Max. pull force	kN	200	200

Above pile lengths are based on an X dimension of 500 mm (see above illustration) with clamped pile.

Hydraulic hammer

H 6

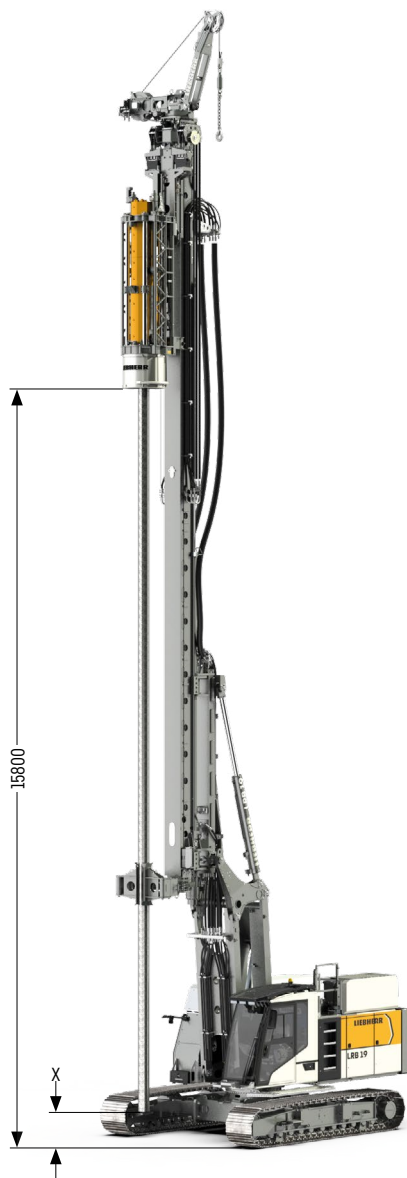

Performance data

Hammer type		H 6-3	H 6-4	H 6-5	H 6-6
Drop weight	kg	3000	4000	5000	6000
Max. rated energy	kNm	0-36	0-48	0-60	0-72
Blow rate	Blows/min	50-150	50-150	50-150	40-150
Max. recommended pile length	m	15.5	15.5	15.5	15.5
Hammer weight incl. pile helmet and dolly	kg	6700	7700	8700	9700

Various pile helmet sizes up to diameters of max. 630 mm for the hammer H 6, or in square design available as standard. Above pile lengths are based on an X dimension of 500 mm (see above illustration) with pile mounted in the hammer. Other pile helmet sizes available on request

Pre-drill

BA 35

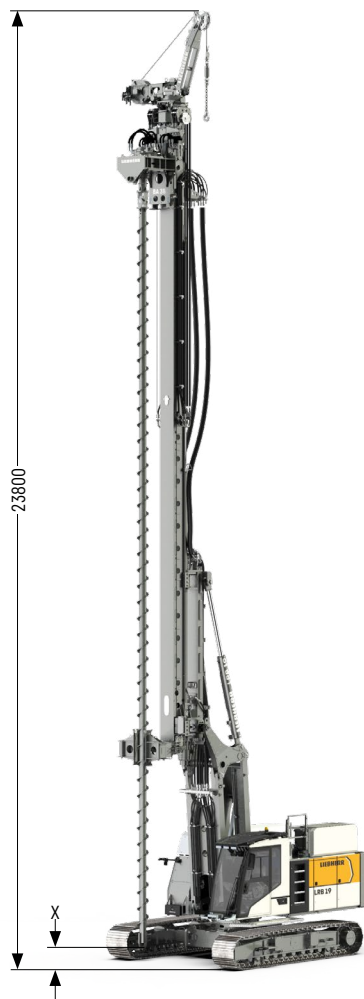

Performance data

Rotary drive - torque	kNm	0-35
Rotary drive - speed	rpm	0-95
Max. drilling depth	m	17.9
Max. drilling diameter*	mm	500

Above drilling depth is based on the use of standard tools and an X dimension of 490 mm (see above illustration).

* Other drilling diameters available on request

Full displacement drilling

BAT 180.1

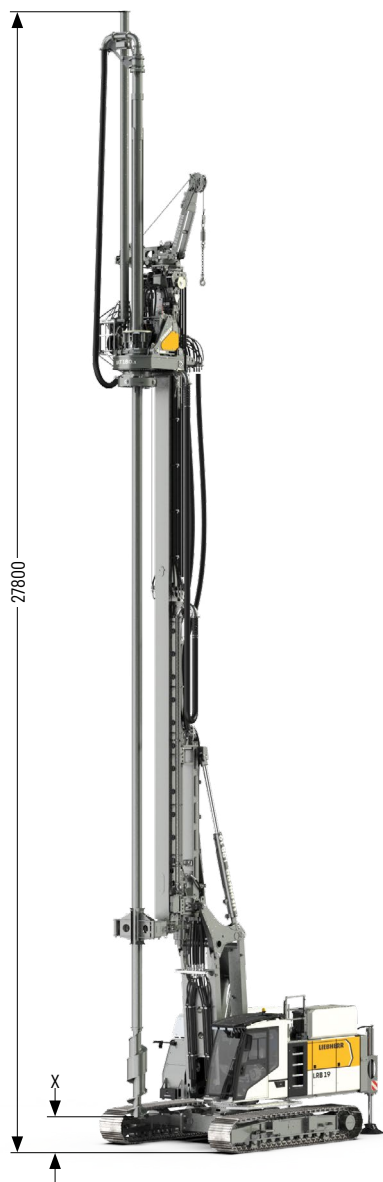

Performance data

Rotary drive - torque	kNm	0-180
Rotary drive - speed	rpm	0-52
Max. drilling depth	m	17.8
Drilling depth with 6 m Kelly extension	m	23.8
Max. drilling diameter*	mm	600
Max. pull force (crowd winch and additional winch)	kN	360

Above drilling depths are based on the use of standard tools and an X dimension of 550 mm (see above illustration).

* Other drilling diameters available on request

Continuous flight auger drilling

BAT 180.1

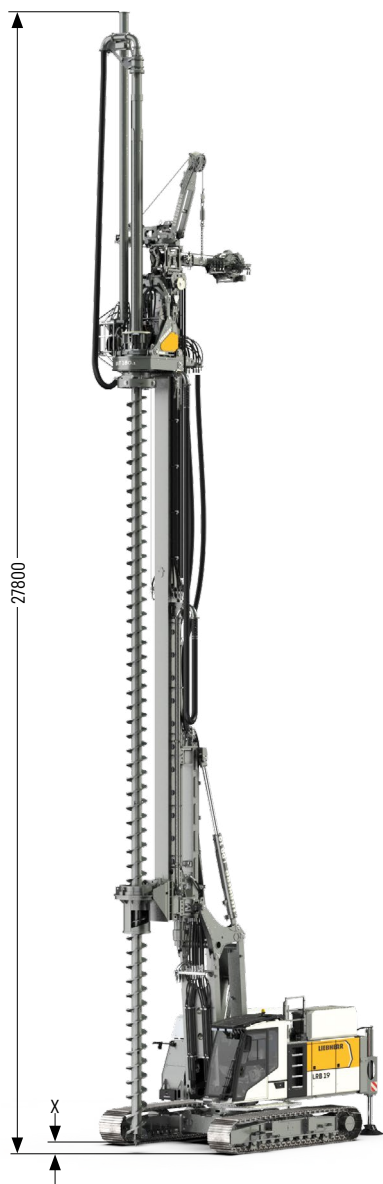

Performance data

Rotary drive - torque	kNm	0-180
Rotary drive - speed	rpm	0-52
Max. drilling depth	m	16.2
Drilling depth with 6 m Kelly extension	m	22.2
Max. drilling diameter*	mm	800
Max. pull force (crowd winch and additional winch)	kN	360

Above drilling depths take into account an auger cleaner and a dismantled cardan joint.

Above drilling depths are based on the use of standard tools and an X dimension of 900 mm (see above illustration).

* Other drilling diameters available on request

Double rotary drilling

DBA 140

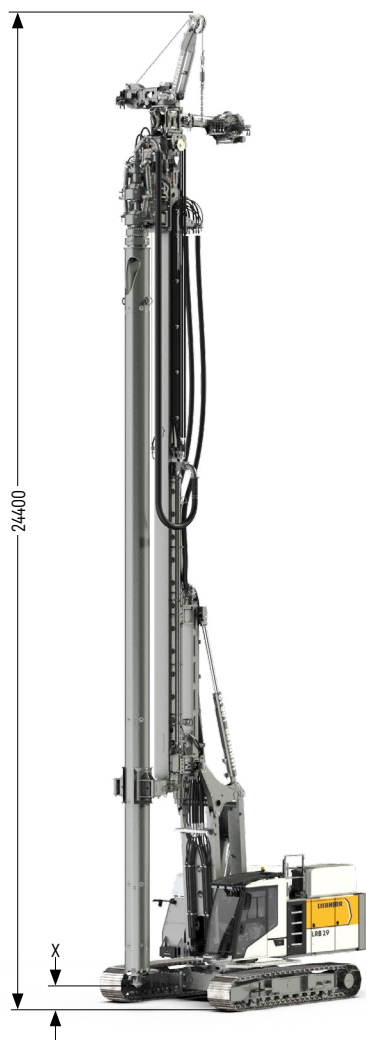

Performance data

Rotary drive I - torque	kNm	0-140
Rotary drive I - speed	rpm	0-29
Rotary drive II - torque	kNm	0-70
Rotary drive II - speed	rpm	0-46
Max. drilling diameter*	mm	800
Max. drilling depth	m	16.0
Max. pull force (crowd winch and additional winch)	kN	360

Above drilling depth is based on the use of standard tools and an X dimension of 520 mm (see above illustration).

Due to differences in the max. admissible load capacities, the combinations of drilling depth and drilling diameter may be limited.

* Other drilling diameters available on request

Soil mixing

3MA 65

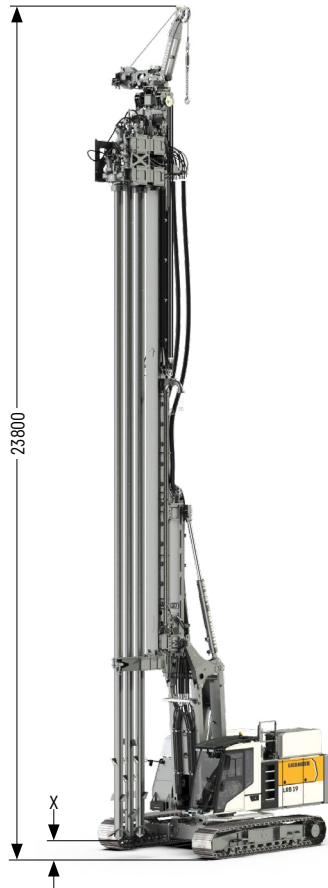

Performance data 3MA 65

Rotary drive - torque	kNm	0-65
Rotary drive - speed	rpm	0-120
Centre-to-centre distance adjustable in steps of 50 mm	mm	450-700
Max. mixing depth	m	17.6
Max. pull force (crowd winch and additional winch)	kN	360

Above mixing depth is based on the use of standard tools and an X dimension of 530 mm (see above illustration).

Longitudinal or transverse mounting of the mixing equipment possible

BAT 180.1

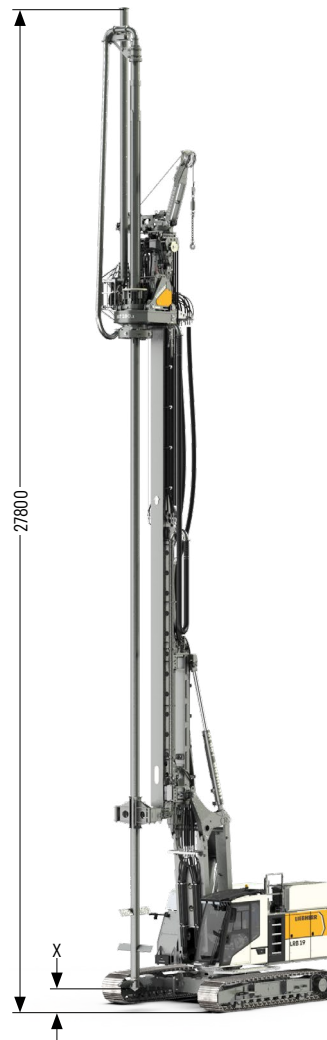

Performance data BAT 180.1

Rotary drive - torque	kNm	0-180
Rotary drive - speed	rpm	0-52
Max. mixing depth	m	18.0
Mixing depth with 6 m Kelly extension	m	24.0
Max. mixing diameter*	mm	1500
Max. pull force (crowd winch and additional winch)	kN	360

Above mixing depths are based on the use of standard tools and an X dimension of 280 mm (see above illustration).

* Other mixing diameters available on request

Kelly drilling

BAT 180.1

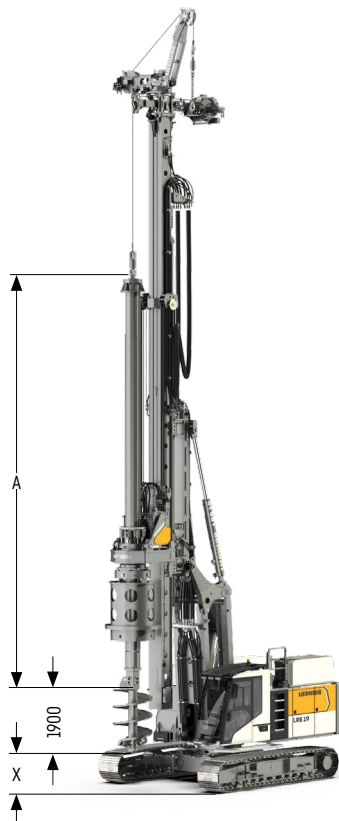

Performance data

Rotary drive - torque	kNm	0-180
Rotary drive - speed	rpm	0-52
Max. drilling diameter uncased	mm	1500
Max. drilling diameter cased*	mm	1200
Max. drilling diameter below the leader	mm	2800

Other drilling diameters available on request

* Depending on casing driver configuration

Technical data Kelly bars

Model	Length A [mm]	X [m]	Drilling depth [m]	Weight [t]
20/2/18	10500	7.8	18.6	3.6
20/3/15	6970	11.3	15.6	3.2
20/3/18	7949	10.3	18.6	3.8
20/3/21	8949	9.3	21.6	4.0
20/3/24	9949	8.3	24.6	4.4

* Installation only possible with assist crane

Above X dimension results from the min. radius and max. height adjustment position

Down-the-hole drilling

DHR 110

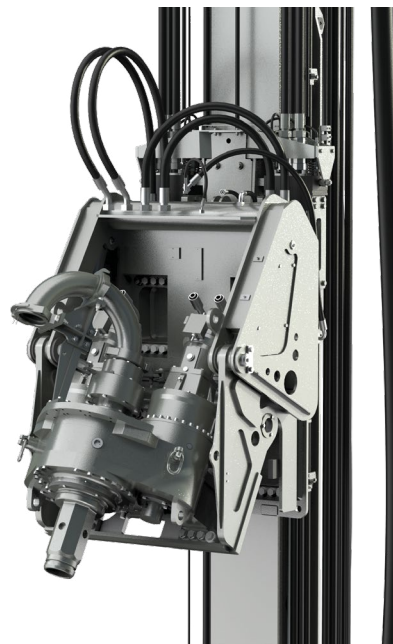

Performance data		DHR 110
Rotary drive - torque	kNm	0-110
Rotary drive - speed	rpm	0-69
Drilling depth	m	17.9
Folding function	°	0-90
Max. pull force (crowd winch and additional winch)	kN	360

Above drilling depth is based on the use of standard tools and an X dimension of 530 mm (see above illustration).

Vibrator LV 23 and LV 23 F

With the LV 23 Liebherr provides a powerful and innovative high frequency vibrator for installing and extracting steel sheet piles, steel pipes and other piling elements.

Thanks to the use of state-of-the-art components, the vibrator is particularly easy to maintain.

It is leader-mounted on the LRB series of carrier machines. These deliver the necessary pull and push force through their rope crowd systems.

The high frequency vibrator LV 23 F is specially designed for all common methods of ground improvement. This includes the installation of vibro-replacement columns or vibrated cast-in-place piles. The flexible suspension of the exciter block in the yoke counterbalances the angular errors between piling element and leader, which is unavoidable in this application. This also minimises the loss of performance as well as the wear on all parts.

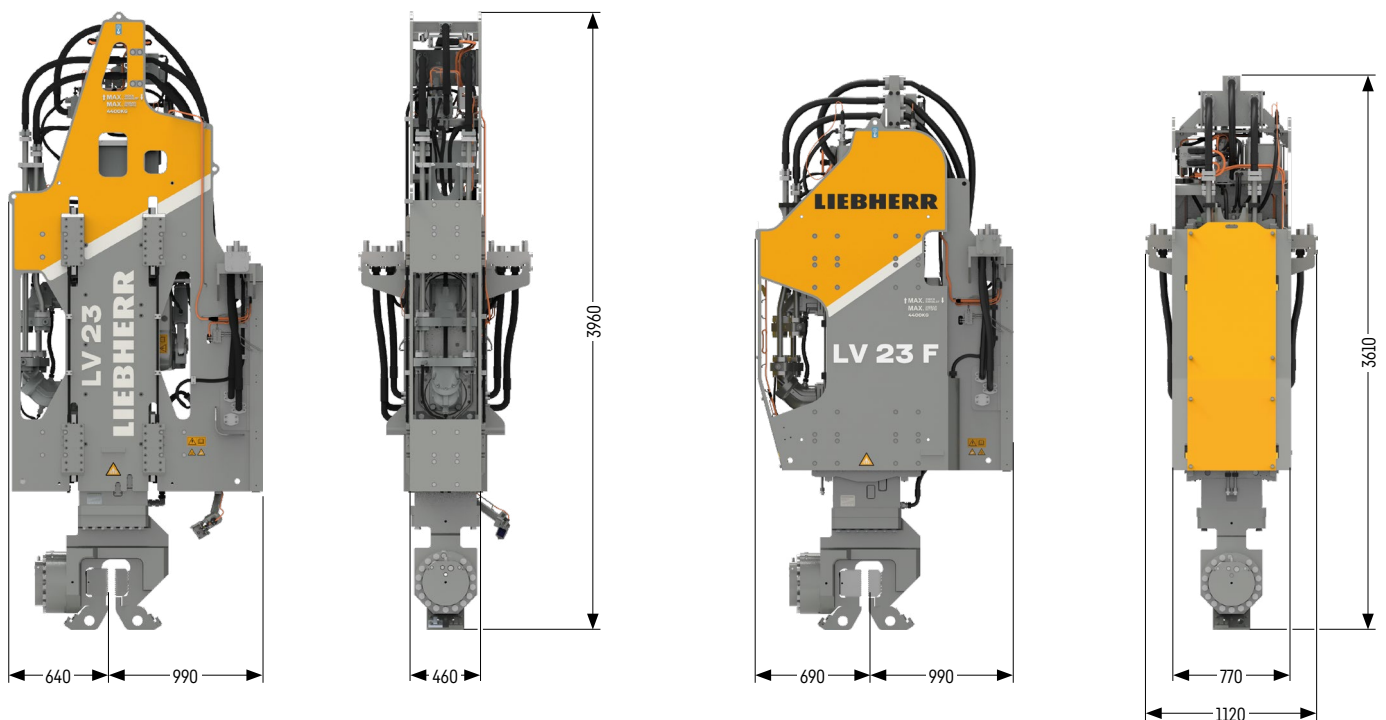

Features

Hose guide

- Parallel movement of hose sledge and crowd sledge (positive control)
- No loosening or overloading of the hoses
- No hose packages and therefore no restriction for sheet piling work

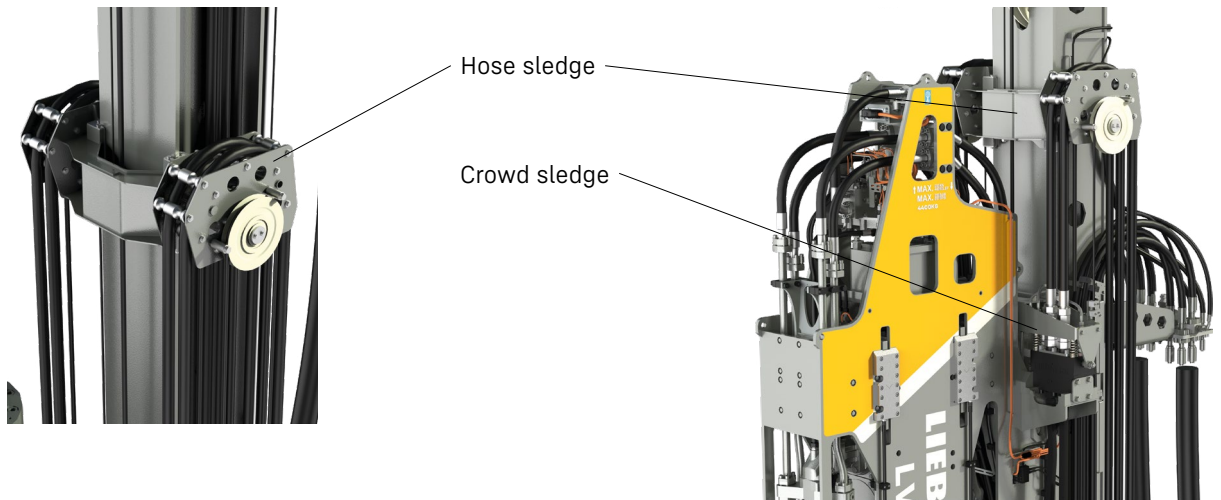

Docking station

- Fully automatic coupling (hydraulic, mechanical and electronic) for easy change of attachments



Digital solutions

Liebherr-Werk Nenzing GmbH has set itself the goal of using digital solutions to network and optimise processes on the jobsite.

In the progression from an experienced machine manufacturer to a full-service provider Liebherr already has a number of digital solutions, which provide substantial support for all those involved in the construction site.

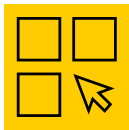

MyLiebherr

One portal, all services

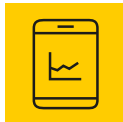

PDE

Process data recording



MyJobsite

Your jobsite at a glance



LIPOS

Positioning system



XpertAssist

Remote support in real time



LiDAT

Data transfer and positioning system



MyNotifier

Monitoring tool for wind conditions and battery status

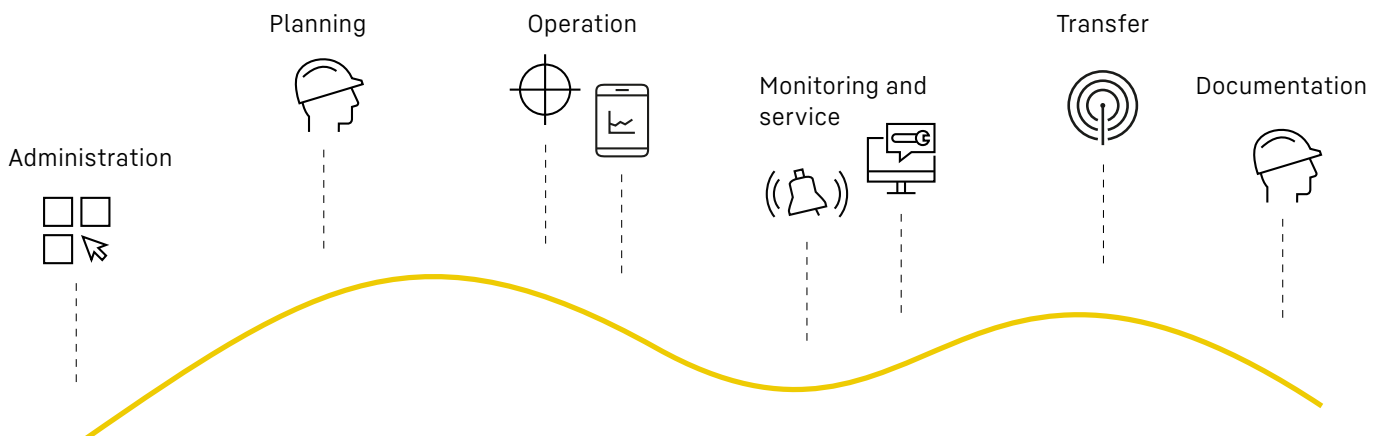



Download datasheet



Please contact us.

Liebherr-Werk Nenzing GmbH · Dr. Hans Liebherr Str. 1 · 6710 Nenzing, Austria
Phone +43 50809 41-473 · foundation.equipment@liebherr.com · www.liebherr.com
facebook.com/LiebherrConstruction